

UNIT I
BACKGROUND MATERIAL

Forensic serology, if taken in its broadest sense to include all aspects of the medico-legal examination of blood and body fluids, draws its methods and the basis of its activities from a number of traditional intellectual disciplines. Foremost among these are biochemistry, immunology and genetics.

This being a sourcebook, an effort has been made to provide background on the various methods and concepts discussed as they come up. As a result, many aspects of biochemistry, genetics and immunology are discussed in connection with the various procedures and tests which are used in forensic practice. Such an approach necessarily presents much of the material of a particular unified body of knowledge in a rather disjoint manner. Unit I has been included in order to provide some background material in the unified disciplines in a more organized fashion. This treatment is brief and topical. No effort has been made to provide detailed documentation of the background material, for that approach would be the equivalent of preparing a sourcebook in one of these related fields. References are given, many of

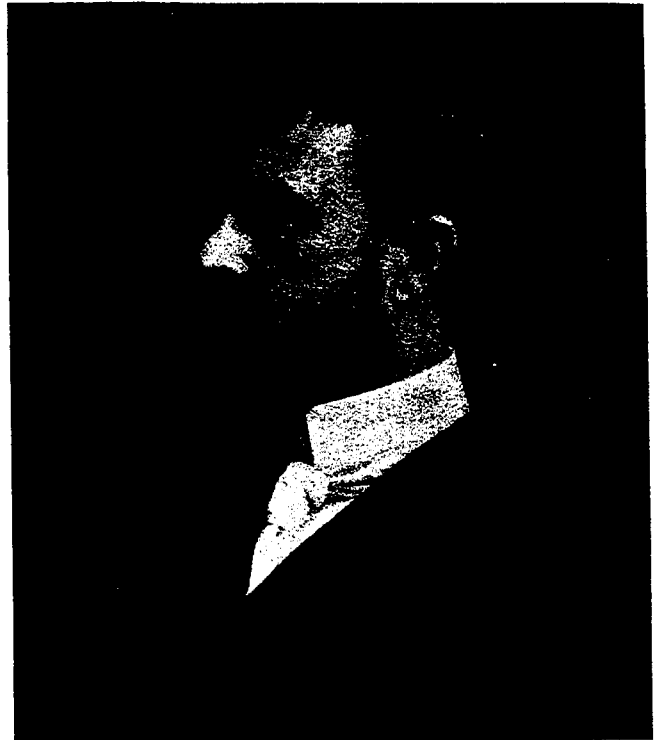
them to standard texts, review articles, and so forth. Just as detailed documentation was not in order for this unit, neither was complete treatment of the various disciplines. Topics for inclusion were selected on the basis of their relevance to forensic serological tests or methods. A few topics which are not particularly relevant to medico-legal practice, have been briefly discussed for the sake of completeness.

The material included in the background chapters is not regarded as being essential to the use of the succeeding units of the Sourcebook. Cross references have been included, where relevant, however, so that readers who may wish to consult the background material on a particular subject in some context will be able to locate it without undue difficulty.

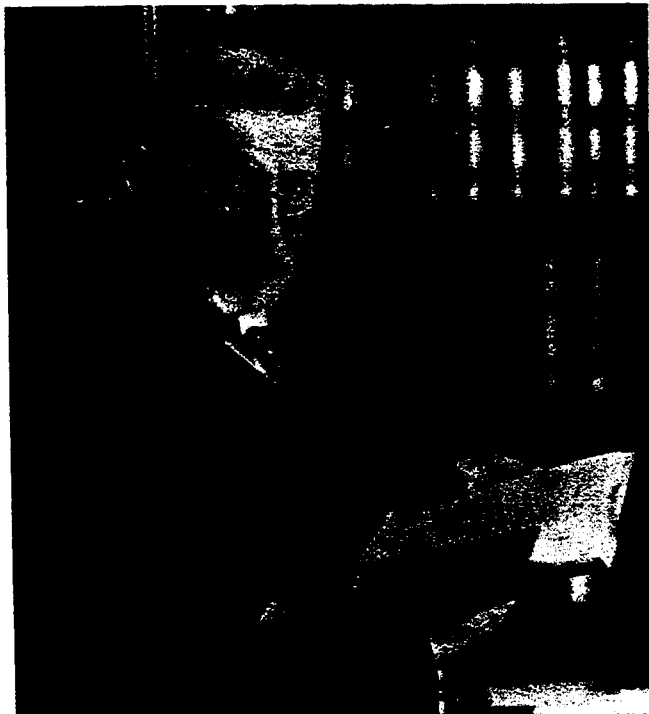
Unit I consists of two sections, the first consisting of background material in biochemistry, immunology and genetics and the second consisting of background material of various selected methods which are widely used in forensic serology, immunology and biochemistry.



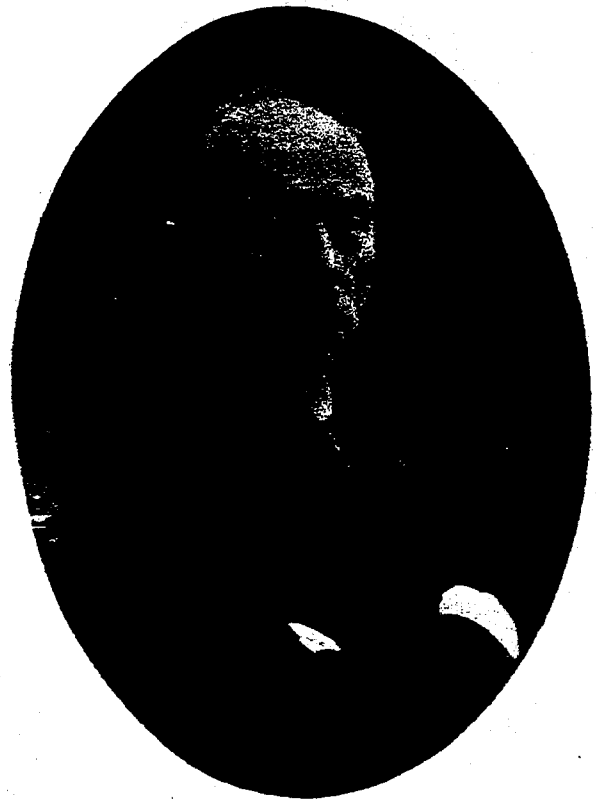
Gregor Mendel 1822–1884
Courtesy National Library of Medicine



Thomas Hunt Morgan 1866–1945
Courtesy National Library of Medicine



Paul Ehrlich 1854–1915
Courtesy National Library of Medicine



Jules Bordet 1870–1961
Courtesy National Library of Medicine

SECTION 1. BACKGROUND MATERIAL IN BIOCHEMISTRY, GENETICS AND IMMUNOLOGY

1.1 Biochemistry

1.1.1 Classes of biologically important organic compounds

In this section, the structures of the major classes of compounds of interest in biochemistry will be described. These are carbohydrates, lipids, amino acids and proteins and nucleotides and nucleic acids. Vitamins and coenzymes could comprise another category, but will not be discussed in great detail here. Some specialized types of molecules are discussed in other units, where germane. Porphyrins and hema-tin compounds, for instance, are discussed in section 4.1

1.1.1.1. Carbohydrates. The carbohydrates are polyhydroxy aldehydes and ketones. The aldehydes are called *aldoses*, and the simplest of these is glyceraldehyde, a three-carbon compound. There are four-, five-, six- and seven-carbon compounds as well. Dihydroxyacetone is the simplest of the ketones, called *ketoses*, and there are likewise important four-, five- and six-carbon compounds in the group. These simplest carbohydrates, called *monosaccharides*, often have one or more asymmetric carbon atoms, giving rise to 2^n stereoisomers, where n is the number of the asymmetric carbon atoms in the molecule. With aldohexoses, for example, where $n = 4$, there are 16 possible stereoisomers, 8 of which are mirror images of 8 others. The pairs of compounds which are mirror images are designated D- and L-, and the D-sugars may be thought of as being derived from D-glyceraldehyde in terms of absolute configuration. Similarly, the L-sugars may be thought of as being derived from L-glyceraldehyde. The D-series of three-, four-, five- and six-carbon sugars is shown in Fig. 1.1. Formulas used in this figure are called Fisher projection formulas, and can adequately represent the D- and L-forms of the compounds. In solution, however, D-glucose or any other sugar, may show different behavior with respect to the rotation of plane polarized light. This phenomenon comes about because the molecule exists in solution as a cyclic hemiacetal, for which two structures are possible. These are usually represented by so-called Haworth formulas, as shown for glucose in Fig. 1.2. Aldohexoses normally form six membered rings through a C_1-C_5 interaction, while ketoses, such as fructose, form five membered rings through a C_2-C_5 interaction. The C_1 which can have its hydroxyl group oriented above or below the plane of the ring is called the anomeric carbon. The two optically distinct forms, α - and β -, are called anomers. The six-membered rings are termed *pyranoses* in systematic nomenclature, while the five-membered rings are called *furanoses*, by analogy to pyran and furan.

More complicated carbohydrates are, for the most part, polymers of monosaccharides. They may be homopolymers,

and can vary in size from disaccharides (two monomeric units) to very large molecules (polysaccharides) like starch or glycogen. Different bonding arrangements between monomeric units are possible. Bonds in which the C_1 of one unit is attached to the C_4 of the next are relatively common. These are called 1 \rightarrow 4 linkages. If the C_1 (anomeric carbon) is in the α -configuration, the bond is called $\alpha 1\rightarrow 4$, while if it is in the β -configuration, the bond is $\beta 1\rightarrow 4$. Figures 1.3 and 1.4 show maltose, which has an $\alpha 1\rightarrow 4$ bond, and cellobiose, which has a $\beta 1\rightarrow 4$. Both consist of glucose units. Long chains may be formed too, such as that of amylose (Fig. 11.1). Branched polymers such as amylopectin (Fig. 11.2) are possible, and are characterized by $\alpha 1\rightarrow 6$ bonds at the branch points.

1.1.1.2 Lipids. The lipids are perhaps the most structurally diverse class of compounds. They are considered together primarily on the basis of their solubility in organic solvents. As a class, lipids are nonpolar, hydrophobic materials. The simple lipids are neutral triglycerides and waxes. Triglycerides consist of glycerol, with three moles of esterified fatty acid. The fatty acids are simple aliphatic organic acids, derived from alkanes or alkenes. They may be saturated (having no double bonds in the chain) or unsaturated (one or more double bonds in the hydrocarbon chain). The most important fatty acids are the C_{12} through C_{20} saturated compounds, the C_{16} acid with a 9,10-double bond and the C_{18} acids with either one, two or three double bonds. The structure of a triglyceride is shown in Fig. 1.5. Waxes are esters in which both the acid and the alcohol moieties have long hydrocarbon chains.

The more complex lipids may be phosphoglycerides, sphingolipids, glycolipids, steroids or carotenoids. Phospholipids are derivatives of phosphatidic acid (Fig. 1.6). The phosphoric acid residue may be esterified again to various compounds, as indicated in Fig. 1.7. The most common compounds which are found as the "X" in Fig. 1.7 are glycerol, inositol, ethanolamine, choline and serine. The compounds thus formed are then called phosphatidyl glycerol, phosphatidyl inositol, and so forth. These are actually classes of compounds, since the fatty acid residues can vary.

Sphingolipids are those derived from sphingosine (Fig. 1.8). An example is sphingomyelin (Fig. 1.9) which occurs in nervous tissue. Glycolipids are compounds consisting of carbohydrate and lipid moieties in covalent linkage. They are very important in some animal cell membrane structures. Major classes of glycolipids are the cerebrosides and the gangliosides. Complete hydrolysis of cerebrosides yields sphingosine, one or two moles of fatty acid and a simple sugar, usually glucose or galactose. Gangliosides are

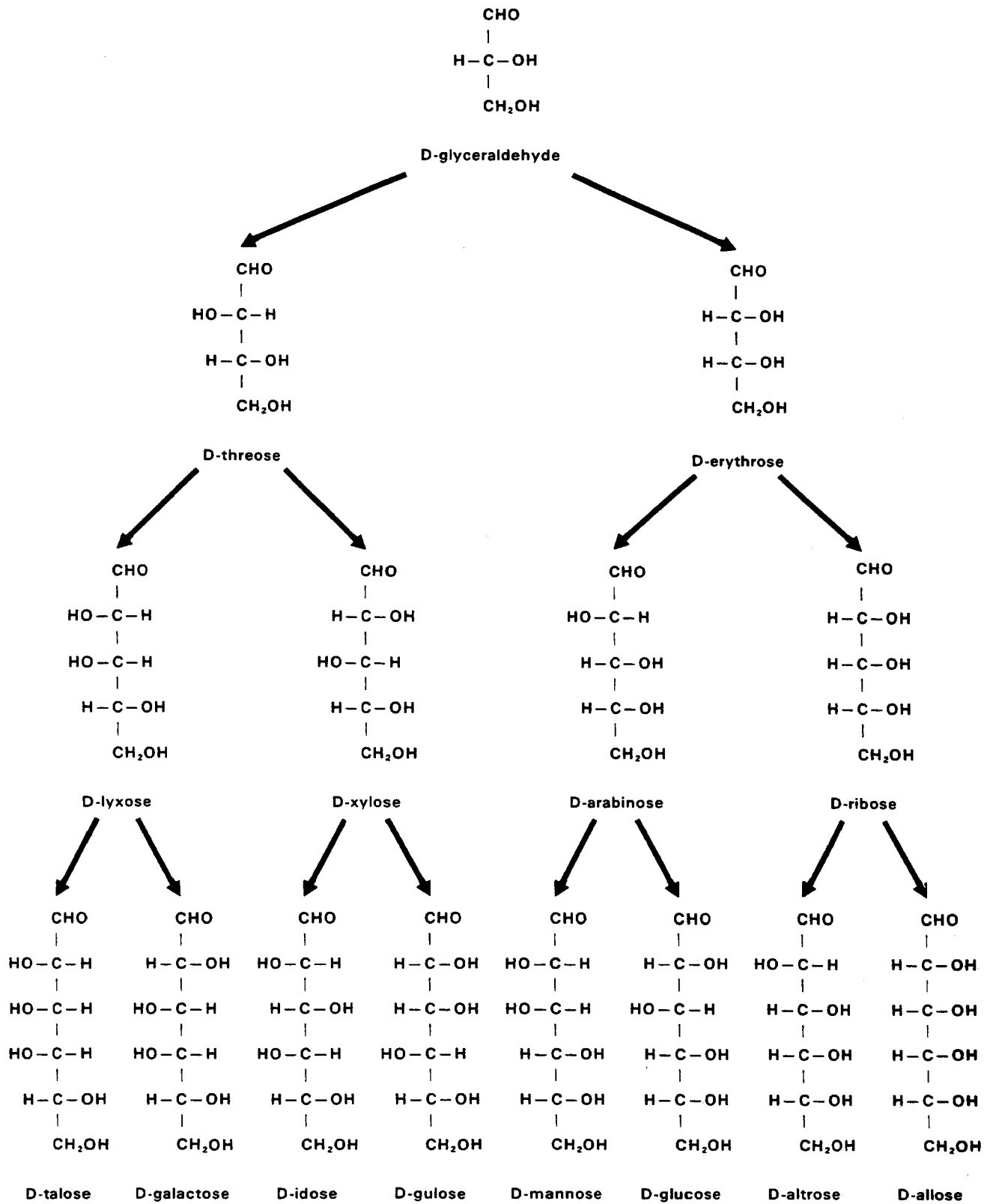


Figure 1.1 D - Series of aldoses

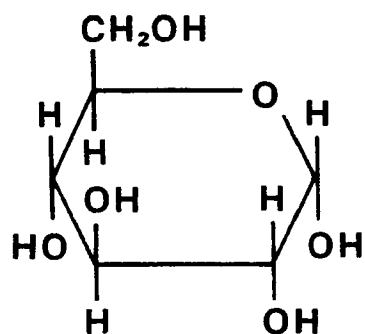
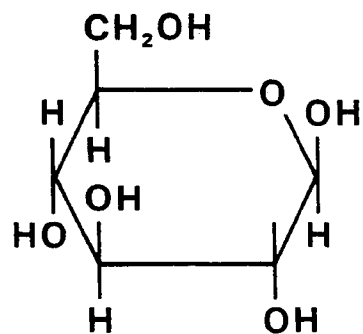
 α -D-glucopyranose β -D-glucopyranose

Figure 1.2 Haworth formulas for the anomers of glucose

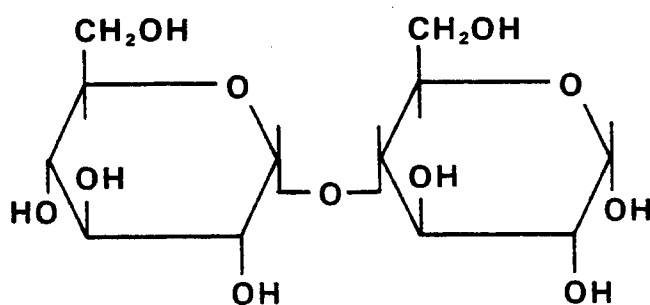


Figure 1.3 Maltose

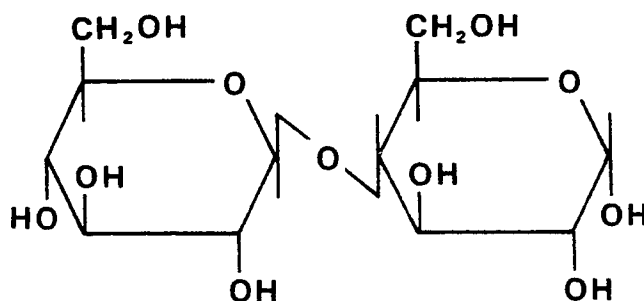


Figure 1.4 Cellobiose

derivatives of cerebrosides and contain a more complex carbohydrate moiety, such as N-acetylated amino hexoses or neuraminic acid. The latter is a modified C₃ hexose (Fig. 1.10 and is also called sialic acid.

Steroids and sterols comprise another class of lipids. They are characterized structurally by a fused hydrocarbon ring system known as perhydrocyclopentanophenanthrene (Fig. 1.11). The conventional ring numbering system is also

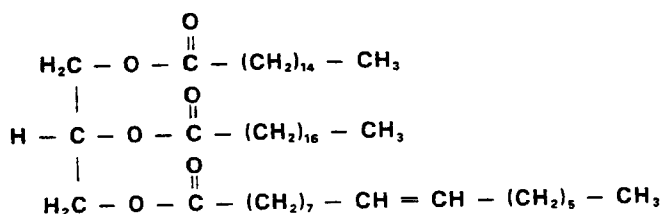


Figure 1.5 A Triglyceride

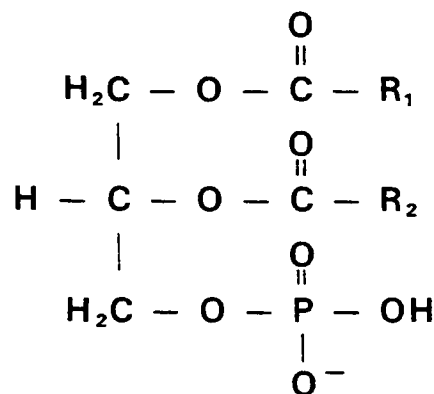


Figure 1.6 A phosphatic acid

given in the figure. The most abundant sterol in animals is cholesterol (Fig. 1.12). The major male and female sex hormones, testosterone (Fig. 1.13) and estradiol (Fig. 1.14) belong to this class of compounds as well.

Carotenoids may be of two kinds, carotenes and xanthophylls, the latter being most abundant in plants. Carotenes are members of a group of compounds called isoprenoids, because they are derived from isoprene

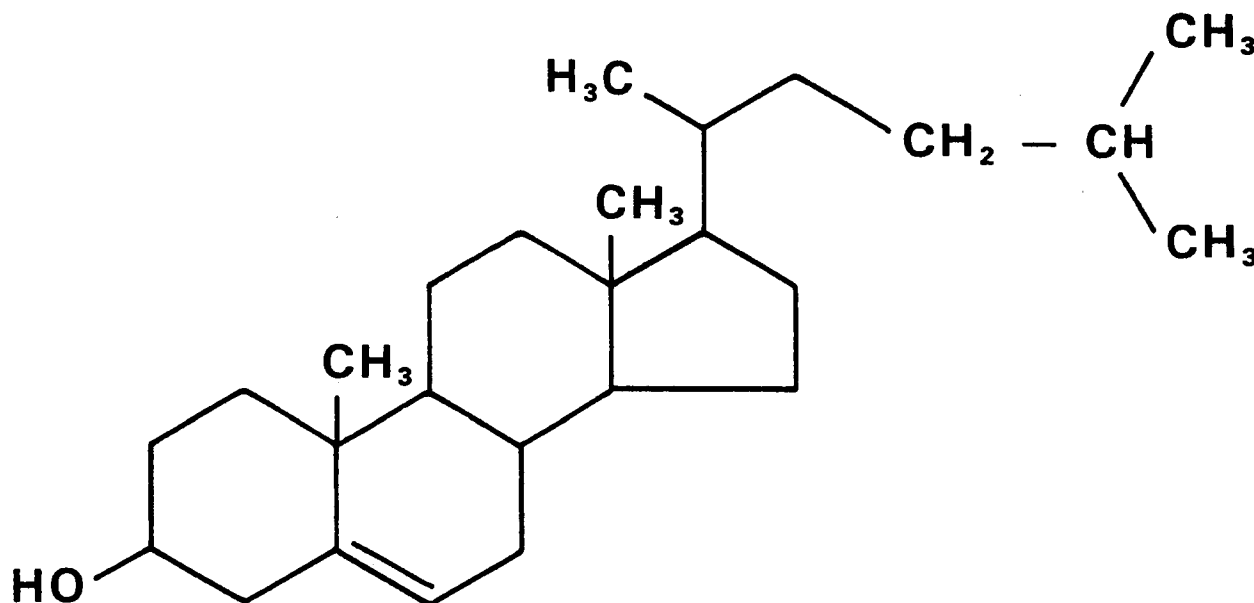
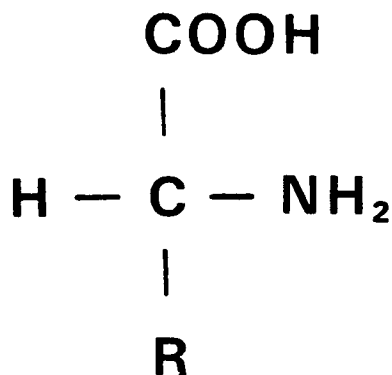


Figure 1.12 Cholesterol

(Fig. 1.15). β -carotene (Fig. 1.16) is a good example of a carotenoid. It is a C₄₀ molecule, and oxidative cleavage at the double bond in the middle of the molecule yields two molecules of the alcohol form of Vitamin A.

1.1.1.3 Amino acids and proteins. Proteins are polymers of amino acids, linked together by peptide bonds. Peptide bonds link the $-\text{COOH}$ of one amino acid residue to the $-\text{NH}_2$ of the next one. Amino acid polymers may also be referred to as *polypeptides*. This term implies a smaller molecule than does *protein*, but may be used to distinguish distinct chains within a single molecule which are bonded together by other than peptide linkages. Smaller polypeptides are sometimes called *oligopeptides*.

A few more than 20 amino acids occur in proteins in nature. All have the basic structure



where the nature of R determines which amino acid is which. The C to which the H, the COOH and the NH₂ are bonded is called the α -carbon. If the R group contains a carbon chain, its carbons are sometimes designated by sequential Greek letters running from α . Thus, we may refer to the ϵ -NH₂ group of lysine, for example. Table 1.1. shows the

naturally occurring amino acids. Each has a more or less standard abbreviation of its name, and these are given in the table as well. The abbreviations are used in writing in sequences of polypeptides, and for the sake of brevity generally. They appear frequently in the remainder of the text of the sourcebook. When R in the generalized amino acid formula above is anything other than hydrogen, the α -carbon is asymmetric and the amino acid exhibits optical isomerism, i.e., it exists in both D- and L-forms. Glycine is the only amino acid which does not show these isomers. The majority of amino acids which does not show these isomers. The majority of amino acids in nature are in the L-configuration. The amino acids, as can be seen in Table 1.1, may be neutral, acidic or basic, and may contain sulfur, hydroxyl groups or aromatic rings. Since amino acids contain a carboxyl and an amino group and in many cases other ionizable groups, their ionic form depends upon the pH. This behavior is illustrated in Fig. 1.17. Each ionizable group is

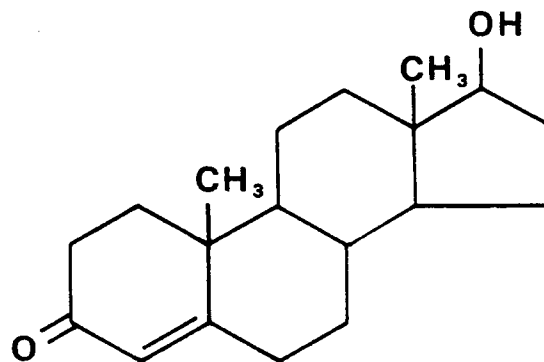


Figure 1.13 Testosterone

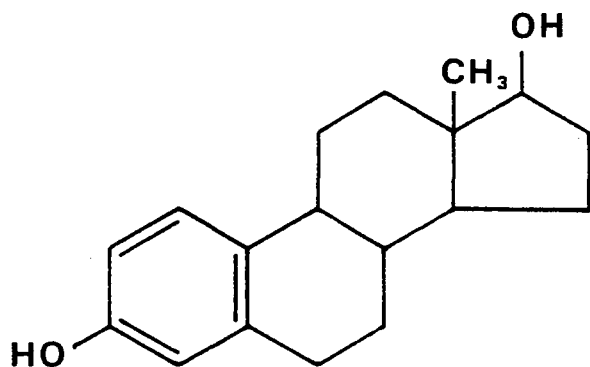


Figure 1.14 Estradiol

characterized by a particular pK_a , the pH at which the protonated and unprotonated forms are present in equal concentrations.

Polymerization of amino acids by means of peptide bonds involves both the α -amino and α -carboxyl group of every residue in the chain except for the ones at the ends. At one end, the amino acid will have a free amino group and the amino acid at the other end will have a free carboxyl group. By convention, the former is written to the left, and is called the N-terminal or amino-terminal end. The latter is called the C-terminal or carboxy-terminal end. Protein structure will be discussed in somewhat more detail in Section 1.1.2.

1.1.1.4 Nucleotides and nucleic acids. These compounds are of interest primarily because of the role they play in biochemical genetics. Their structure is discussed in that context in Section 1.2.2.3.

1.1.2 Proteins

1.1.2.1 Protein structure. Proteins have several levels of structure, which come about because of the large size of these molecules. The *primary* structure is the amino acid sequence. There can be interchain or intrachain disulfide bonds (or disulfide bridges), in which two cysteine residues have their sulfur atoms bonded to one another. Formation of a disulfide bond from the Cys residues is oxidative, in that two hydrogens are removed. In longer protein chains, another level of structure is generated by intrachain hydrogen bonding among those atoms involved in the peptide link-

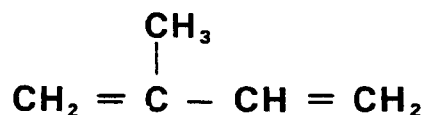


Figure 1.15 Isoprene

ages, and is known as *secondary* structure. The secondary structure may consist of helical or pleated sheet configurations. Finally, proteins generally fold up into more or less complicated three-dimensional structures, and this folded arrangement is known as the *tertiary structure*. The special configuration of every protein is unique. A number of forces are responsible for the maintenance of the three-dimensional conformation of proteins. These forces involve the side chains of the amino acids which constitute the protein. Electrostatic interactions may occur between oppositely charged groups, such as the $\epsilon\text{-NH}_3^+$ group of lysine and the side chain -COO^- group of glutamic acid. These interactions are sometimes called "salt bridges". Hydrogen bonding not involving atoms involved in the peptide linkage may occur, such as between the -OH of tyrosine and a carboxyl group of Glu or Asp. Peptide bond hydrogen bonding between different segments of chains of Ala, Val, Leu, Ileu, and Phe are important as well. The sum of all these forces is responsible for maintaining the conformation. There are obviously a large number of different combinations of these interactions which are possible in a particular protein, each of which would lead to a somewhat different conformation. The protein molecule generally assumes the most stable conformation available, maximizing interactions which lend structural stability. In aqueous solution, protein conformation is influenced by the stabilizing effect of having the polar side chains exposed to the aqueous environment, and the nonpolar side chains away from water and more inside the core of the molecule. Under a given set of conditions, a protein will assume a particular conformation, its most stable under those conditions. This structure is determined by the particular amino acid sequence. A specified primary structure gives rise to a unique three-dimensional folded structure. The sum of all the side chain interactions leading to the tertiary structure is a unique function of the sequence. Because of the complex way in which protein molecules do fold up, they assume conformational shapes which have a kind of "inside" and "outside" to them. It is proper to speak

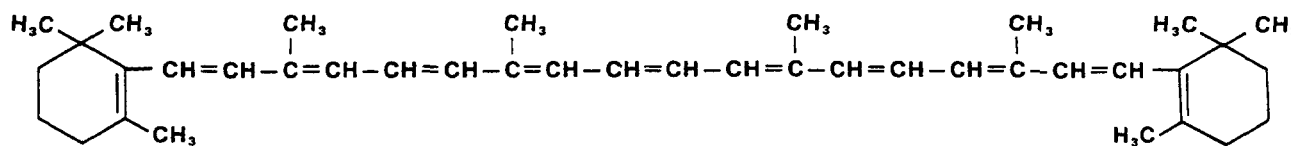
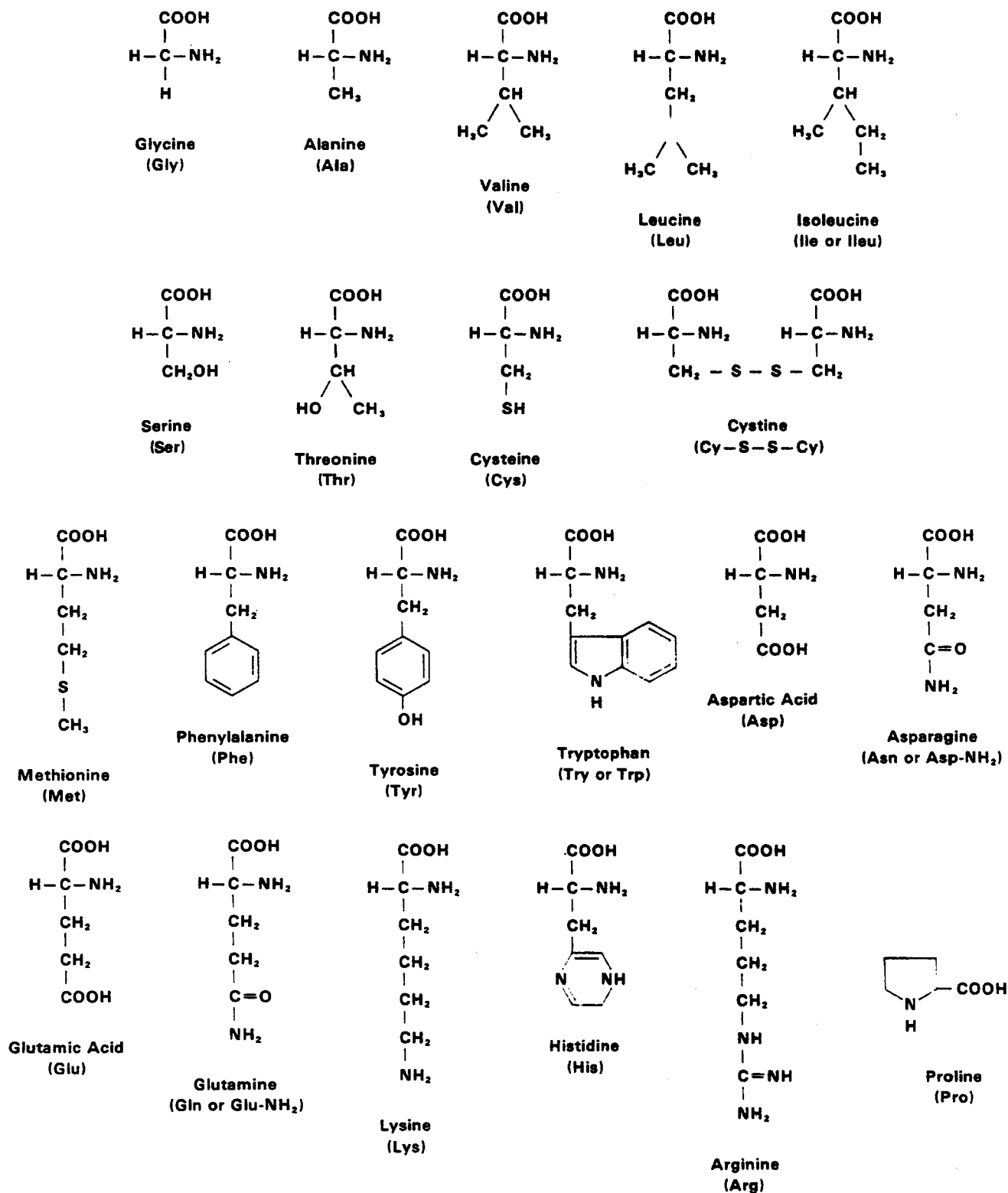


Figure 1.16 β -Carotene

Table 1.1 The Amino Acids



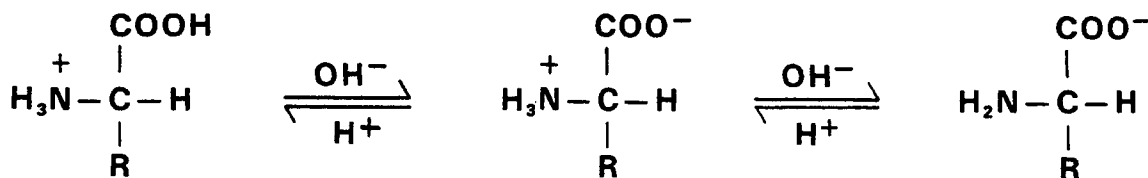


Figure 1.17 Ionic Forms of an Amino Acid

of the "surface of the molecule" with proteins. A fourth level of structure is possible for proteins which consist of two or more distinct polypeptide chain subunits. Called *quaternary* structure, this level refers to the association of two or more individually folded polypeptide chain subunits into aggregates, as the result of non-covalent forces. The number of subunits in such a protein can vary, some proteins consisting of 10 or 12 subunits. Hemoglobin is a good example of a subunit protein. Normal Hemoglobin A consists of four chains, two called α -chains and the other two called β -chains. Each chain complexes a heme group, and the intact molecule is a tetramer, often denoted $\alpha_2\beta_2$, and containing four heme groups (see in section 38).

It should be noted that complete structures are known for very few proteins. Methods of sequence analysis have improved to the extent that sequences are known for a fair number of proteins. It is more difficult and laborious, however, to obtain information about the secondary and tertiary structures. Detailed three-dimensional structures are known for very few proteins. These structures are determined using x-ray crystallography.

Any level of structural analysis of a protein requires that it first be obtained in pure form. Purification of proteins is often fairly involved, yields are often poor, and techniques cannot always be found to purify a particular protein to the desired degree. There is also the nagging problem of the extent to which the purification procedure has modified the molecule with respect to its *in vivo* condition. Proteins which are associated with carbohydrates or lipids in some complicated way, or proteins which are constituents of membranes can present extremely difficult purification problems.

1.1.2.2 Protein purification. A variety of techniques are used for purification of proteins. Cell free extracts are prepared first. These preparations are sometimes called "crude extracts." Any method which gets the protein out of the cell and still retains the biological activity of the protein is suitable for preparations of crude extracts. Sometimes, particular cells or organelles may be prepared, and the crude extract made from them. Thus, one might make beef heart mitochondria first, or a preparation of washed red blood cells. Depending upon the cell or preparation in question, sonic oscillations, osmotic shock, treatment with detergents, or a variety of other techniques could be used to get the protein away from the cells or organelles.

Protein solubility depends on the salt concentration. Different proteins differ in this respect, and variation in salt concentration can be used to precipitate proteins from solution. By collecting the precipitates, pouring off the material still in solution, and then making the solution still more concentrated in salt, a series of fractions can be obtained. Ammonium sulfate is commonly used as the salt because of its high solubility. Certain proteins "salt out" at particular ammonium sulfate concentrations, and the fraction containing the protein of interest can be collected, free of all the proteins that are soluble, and subjected to further purification.

Column chromatography is another popular technique. Two major types of techniques are used, and they differ in principle. In ion exchange chromatography, a support matrix is covalently linked with side chain groups which have either positive or negative charges. Depending upon the acidity (pK_a) of the ionizable group, the over-all charge on the column may depend on the pH. Ion exchange resins are called "cation exchangers" or "anion exchangers" depending on whether their fixed charge is positive or negative. Proteins have net charge at all pH except for their isoelectric point (pI), and can be attached to ion exchange resins. The resins are then eluted with increasing concentrations of salt, which competes for the resin exchanger binding sites, and displaces the different proteins according to their net charge and resultant binding strength. Fractions are collected and searched for the protein of interest. A number of resins are in common use, including various Dowex resins and diethyl-aminoethyl (DEAE) cellulose or sephadex, carboxy-methyl (CM) cellulose or sephadex and a number of others. Walton (1975a and 1975b) has discussed ion exchange chromatography in detail, and Peterson (1970) has treated cellulosic ion exchangers in detail.

In so-called gel filtration chromatography, or molecular sieving, separation of the proteins is effected on the basis of size. Sephadex (a product of Pharmacia Fine Chemicals in Sweden) is in very wide use for this purpose. Sephadexes are dextrans, cross-linked to varying degrees in such a way as to create pores within the matrix. There are a number of grades of sephadex, having different pore sizes. Cross linked polyacrylamide gels (Bio Gel P-series, Bio-Rad Laboratories), and agarose gels (Bio Gel A-series, Bio-Rad Laboratories and Sepharoses from Pharmacia Fine Chemicals) are also in

use for molecular sieve chromatography. Molecules passing through the matrix, which are small enough to get into the pores, do so, and their passage is thus retarded in comparison to those molecules which are "excluded." Sephadexes and other gels are calibrated by the manufacturer, usually with globular proteins or polysaccharides. Proteins which have peculiar shapes can behave differently on the gels than would be expected on the basis of their molecular weight. For example, a column which contains a gel support calibrated to exclude molecules of 135,000–150,000 in molecular weight will do so if they are globular. But if a molecule were rod-shaped, interaction with the gel pores could occur in spite of the fact that its molecular weight might be greater than 150,000. Additional detailed information on molecular exclusion chromatography may be found in Determann and Brewer (1975) and Fischer (1969).

Ultracentrifugation is widely employed as a purification technique in biochemical studies. Ultracentrifuges produce very intense gravitational fields. Commercial instruments are generally capable of speeds up to 70,000 rpm, depending upon the rotor, and of generating gravitational fields of up to $500,000 \times g$. Ultracentrifugation techniques may be either sedimentation or density gradient methods. Sedimentation methods are used primarily for characterization and MW studies (see section 1.1.2.4). In sedimentation ultracentrifugation, the medium is of constant density. Density gradient methods are more applicable to isolation and purification. Solutes migrate in these systems in a medium of gradually changing density. In velocity density gradient centrifugation, a solvent medium with a pre-formed linear density gradient is employed, the solute being layered onto the top. Solute materials of differing densities migrate to discrete zones, and are thus separated. In equilibrium density gradient centrifugation, the solute is uniformly mixed with a dense inorganic salt, such as cesium chloride, and a linear density gradient is self-generated under the influence of the gravitational field. Solutes of varying densities will collect in zones corresponding to their own densities and will thus be separated. Fractions from these gradients are readily collected by puncturing the bottom of the centrifuge tube after the run, and collecting fractions in separate tubes. Analytical ultracentrifugation, which is often applied to characterization studies and MW determinations, is briefly discussed in section 1.1.2.4.

At each step of the purification procedure, the material must be assayed for the activity one is trying to purify. Only in this way can it be determined whether a step has worked. One must define units of activity for the protein in some quantitative way in order to have a suitable assay. The assay is based on the protein's function, i.e., whether it is an enzyme, an antibody, etc. After each step of the purification, total protein is determined as well as total units of activity present. The number of units of activity per mg protein is called the *specific activity*. As purification proceeds, the total amount of protein should be decreasing, because unwanted proteins are being purified out, and the preparation should be growing richer in the protein of interest. Specific

activity should therefore increase with each step. If it does not do so, the purification step is probably not a good one for that protein.

1.1.2.3 Estimation of protein. There are a number of protein assays in use. The biuret method is based on the fact that compounds containing two or more peptide bonds form a deep blue-purple color with cupric salts in alkaline solution. The reagent is prepared from cupric sulfate, sodium potassium tartrate and NaOH. Optical density is determined in the 540–560 nm region. The method was devised for serum proteins (Robinson & Hogden, 1940; Weichselbaum, 1946; Gornall *et al.*, 1949), but has been modified by many workers and is applicable to protein determination generally (Layne, 1957).

Protein estimation by means of the Folin-Ciocalteu reagent is also called the "Lowry method" (Lowry *et al.* 1951). The color obtained is the result of the biuret reaction, and the reduction of phosphomolybdic-phosphotungstic acid reagent by tyrosine and tryptophane in the protein (see section 10.3.4 for use of Folin-Ciocalteu reagent for estimating phenol). The method is discussed by Layne (1957).

Most proteins absorb in the ultraviolet region at around 280 nm because of the presence of the aromatic amino acids. Nucleic acids, frequent contaminants of protein preparations, absorb maximally at about 260 nm. Warburg and Christian (1942) first described a technique for estimating protein concentration by 280 nm absorption, and putting in a correction for the nucleic acid absorption. In practice, the absorbancy is determined at both 260 and 280 nm and appropriate calculations carried out. Tables, such as the one presented by Layne (1957), simplify the calculations.

Bradford (1976) described a sensitive and rapid protein assay, based on the binding of the protein to Coomassie Brilliant Blue G 250 (see Table 5.3). The assay was usable for quantities of protein varying from 1 to 100 μg . The A_{595} was linear with protein concentration to about 50 μg and only slightly nonlinear at higher amounts. Only detergents in relatively high concentrations interfered with the assay.

All the methods have advantages as well as drawbacks. The Lowry method is somewhat more sensitive than the classical Biuret, although the latter's sensitivity can be increased considerably by modifying the technique and scaling down the volumes employed. The Lowry and 280/260 methods depend upon the aromatic amino acid content of the protein, which is not of course always the same. The protein concentration of a protein which has not been purified is usually obtained by reference to a standard curve. The standard curve has been constructed using some pure protein. Reference to the standard curve, therefore, does not give the absolute protein concentration of a protein other than the one used to make the curve, but all measurements carried out with reference to the same standard curve will be internally consistent, relative to one another. Standard curves with the Lowry method often exhibit non-linearity. The Bradford (1976) dye binding assay is not affected by a number of chemicals which interfere with the Lowry assay, and the color is considerably more stable over the course of

time (maximal development in about 2 min and stable for an hour).

1.1.2.4 Criteria of purity and MW determination. It is always difficult to know when a protein preparation is "pure." As a rule, the preparation is subjected to several separation techniques, such as disc electrophoresis or an ion exchange column, and a single band or peak of activity suggests purity. The analytical ultracentrifuge is sometimes used to check preparations for purity, as well as for determination of the MW. The analytical ultracentrifuge can be used to determine a quantity called the sedimentation coefficient (or *s*), which is the velocity of sedimentation divided by the centrifugal field strength ($\omega^2 r$), where *r* is the distance from the center of rotation and ω is the angular velocity of the rotor. The units of *s* are seconds, and since numbers of the order of 10^{-13} sec are commonly encountered, the quantity 1×10^{-13} is defined as 1 Svedberg unit, denoted S. The MW is related to *s* by different equations which can be derived from the theory of ultracentrifugation of macromolecules (see van Holde, 1971).

MW can also be determined by molecular sieving techniques. Sephadex can be used for this purpose. A column of sephadex is prepared for the approximate MW range in which one expects the protein to lie. The column can then be "calibrated" with proteins of known MW. The MW of the unknown protein can then be estimated by how it behaves on the column. A similar thing can be done with polyacrylamide gels, since these are synthetic and of controllable pore size (see section 2). If a protein is pure enough, and can be subjected to a complete amino acid analysis, the MW can be calculated from the composition.

1.1.3 Enzymes

1.1.3.1 Introduction. Enzymes are the cellular protein catalysts. Most biological reactions are enzyme-catalyzed, and the intrinsic rates of the reactions *in vivo* are sufficiently slow that the presence of the enzyme is the factor that allows the reaction to occur at a significant rate. This is one of the ways in which genetic control is exercised over specific reactions (see section 1.2.2). Most enzymes exhibit a high degree of specificity, and their activity is subject to regulation in the cell at a number of different levels. Enzymes which exhibit multiple molecular forms, and are polymorphic, are an important class of genetic markers in blood and body fluids, and therefore, of great interest in legal medicine. The first enzyme to be isolated and purified was urease. This work was carried out by Dr. Sumner in 1926.

1.1.3.2 Enzyme Nomenclature. For years, enzyme nomenclature grew up on an *ad hoc* basis. Names were usually, but not always descriptive, and most of them ended in *-ase*. Some trivial names give no information about the enzyme whatever, e.g. pepsin, trypsin. Eventually, the need for a systematic nomenclature became clear, and an international Commission on Enzymes was set up in 1955 in consultation with the International Union of Pure and Applied Chemistry (IUPAC). The final recommendations of the working group

were adopted in 1964 as the *Recommendations (1964) of the International Union of Biochemistry on the Nomenclature and Classification of Enzymes*. A numerical system was devised, very like the system which has been used to number the sections and subsections of this book. Six major categories of enzymes were established: 1. Oxidoreductases 2. Transferases 3. Hydrolases 4. Lyases 5. Isomerases 6. Ligases. Subsets of oxidoreductases are denoted 1.1, 1.2, 1.3, etc., of transferases, 2.1, 2.2, etc., and so forth. Subsets of 1.1 are denoted 1.1.1, 1.1.2, and so on, and finally, subsets of 1.1.1 would be denoted 1.1.1.1, 1.1.1.2, etc. At the level where there are four numbers, a specific enzyme is denoted, and the result is that all the enzymes which have been described have a four-number systematic designation. In addition, a number of rules on the systematic nomenclature were issued. The original document should be consulted for the detailed rules. It was recognized that trivial names would still be in use, and that it is not always necessary to use the systematic name. The Commission recommended the preferred trivial name in each case. The systematic designation may be illustrated by means of an example: the systematic name of the well-known polymorphic erythrocyte enzyme phosphoglucomutase (PGM) is α -D-glucose-1,6-diphosphate: α -D-glucose-1-phosphate phosphotransferase. PGM has the designation 2.7.5.1. The 2 denotes transferases; 2.7 refers to transferases which transfer phosphate-containing groups; 2.7.5 are phosphotransferases in which donors are regenerated (catalyzing apparent intramolecular transfers); and 2.7.5.1 is phosphoglucomutase. It is now common in the literature to note the four-number designation of an enzyme. The information is sometimes given parenthetically, sometimes accompanied by the systematic name, and generally appears in the title of the paper or at the point of first reference to the enzyme. One normally prefaces the four-number designation with the letters "EC," for "enzyme commission." Thus, one might write "phosphoglucomutase (PGM; EC 2.7.5.1)." Enzymes discussed in this book are identified by their EC number and their systematic names are given at the point of first reference.

1.1.3.3. Kinetics of enzyme catalyzed reactions Kinetics is concerned with reaction rates. Enzyme kinetics is a complex subject, and is not treated in depth in this section. Simple Michaelis-Menten kinetics is presented because the kinetic parameters derived from this kinetic treatment are often used in describing enzymes, and the terminology comes up in subsequent sections.

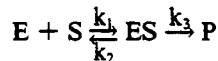
Any reaction is characterized at the molecular level by the number of molecules that must interact prior to product formation. This parameter, the molecularity, can be determined only from a knowledge of the reaction mechanism. The dependence of reaction rate on the concentrations of reactants is specified by the kinetic *order* of the reaction. This parameter is determined experimentally by fitting data to rate equations. Suppose a reaction in which $A \rightarrow B$. The rate of the reaction, or velocity (*v*) is equivalent to the rate of disappearance of reactant and to the rate of appearance of product:

$$v = -\frac{d[A]}{dt} = +\frac{d[B]}{dt} = k[A]^n$$

where [] represents concentration, t is time, and k is the rate constant. The rate constant is the same for a given reaction under a specified set of conditions. The exponent, n , corresponds to the kinetic order of the reaction. If the rate of the reaction is determined at different values of $[A]$, n can be determined. Then k can be determined as well. If $n = 0$, $v = k$, the rate is independent of reactant concentration, and the reaction is said to be *zero order*. If $n = 1$, $v = k[A]$, the rate is directly proportional to $[A]$, and the reaction is said to be *first order*.

Michaelis and Menten studied the kinetics of the enzyme catalyzed hydrolysis of sucrose and, by measuring the initial velocity under different conditions, found that the rate was proportional to the enzyme concentration if substrate was held constant. If enzyme was held constant, the relationship between initial velocity and substrate concentration was found to be hyperbolic. Figure 1.18 illustrates this behavior, which has been found to characterize many enzyme-catalyzed reactions. For various reasons, the rates of enzyme-catalyzed reactions can vary over the course of time, and for this reason it is important to use initial velocities in doing kinetic studies. The Enzyme Commission recommended that enzyme assays be based on the measurement of initial velocities.

In simple terms, an enzyme-catalyzed reaction may be represented:



where E represents enzyme, S represents substrate, ES is the enzyme-substrate complex, P is product, and the k 's are the rate constants. The Michaelis-Menten treatment is based on

a rapidly attained steady state, in which the rates of formation and disappearance of ES are equal, i.e.,

$$\frac{d[ES]}{dt} = -\frac{d[ES]}{dt}$$

$$\text{Since } \frac{d[ES]}{dt} = k_1[E][S] \text{ and } -\frac{d[ES]}{dt} = k_2[ES] + k_3[ES]$$

$$\text{then } k_1[E][S] = k_2[ES] + k_3[ES]$$

Assuming that the rate-limiting step is the formation of ES , the initial velocity (v_o) is proportional to $[ES]$ and the maximum v_o (denoted V_{max}) will be proportional to the total enzyme concentration $[E_t]$ because V_{max} occurs when all E is complexed in ES . The above equation may be rewritten:

$$[ES] = \frac{k_2 + k_3}{k_1} [E][S]$$

Since the proportionality constants relating v_o to $[ES]$ and V_{max} to $[E_t]$ must be the same,

$$\frac{v_o}{V_{max}} = \frac{[ES]}{[E_t]}$$

Solving for ES and substituting in the previous equation yields

$$\frac{v_o}{V_{max}} = \frac{k_1}{k_2 + k_3} = \frac{[E][S]}{[E_t]}$$

The term $\frac{k_2 + k_3}{k_1}$ is defined as K_m , the Michaelis constant.

Thus,

$$\frac{v_o}{V_{max}} = \frac{1}{K_m} \frac{[E][S]}{[E_t]} = \frac{1}{K_m} \frac{([E_t] - [ES])[S]}{[E_t]}$$

and

$$v_o = \frac{V_{max}}{K_m} \frac{[E_t][S]}{[E_t]} - \frac{[ES][S]}{[E_t]} = \frac{V_{max}}{K_m} \left([S] - \frac{[ES][S]}{[E_t]} \right)$$

Substituting $[ES] = \frac{v_o}{V_{max}} [E_t]$ for $[ES]$, rearranging terms,

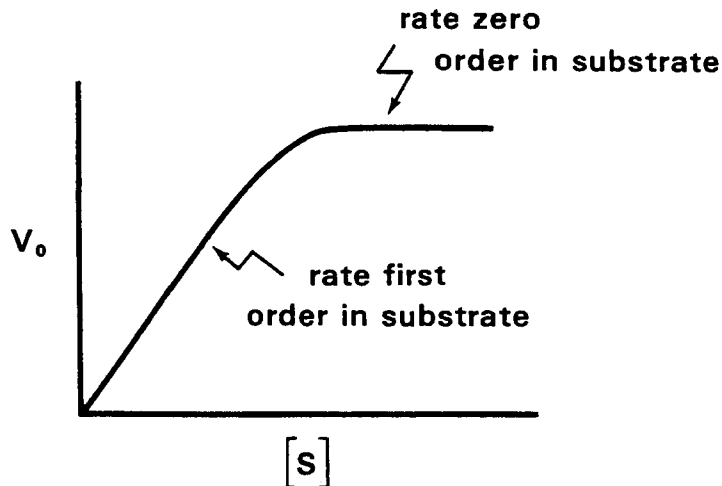


Figure 1.18 Initial Velocity of Enzyme Catalyzed Reaction as a Function of Substrate Concentration

and solving for v_o gives the classical form of the Michaelis Menten equation:

$$v_o = \frac{V_{max} [S]}{K_m + [S]}$$

Two points about this representation are worthy of note. First, if the equation is solved for $[S]$ when $v_o = \frac{1}{2}V_{max}$, it will be found that $[S] = K_m$. In other words, K_m is the substrate concentration when the initial velocity is one half its maximal value. Second, K_m is $\frac{k_2 + k_3}{k_1}$. If k_2 is very much greater than k_3 , then K_m will be approximated by k_2/k_1 , and will be a measure of the affinity of E for S. Since the ES formation rate constant is in the denominator, larger K_m values are interpreted as being representative of lower affinities of E for S.

K_m may be evaluated in a number of ways. The essential data consists of a series of measurements of initial velocity at various $[S]$ at constant $[E]$. The Michaelis Menten equation can be rearranged in various ways to give equations of the $y = mx + b$ form, and K_m can be calculated from plotted data. For example, a plot of $1/v_o$ against $1/S$ yields a straight line with a slope of $\frac{K_m}{V_{max}}$ and a y-intercept of $-\frac{1}{K_m}$, and is called a Lineweaver-Burk plot. A plot of v_o/S against

v_o also yields a straight line, but with a slope of $-\frac{1}{K_m}$ and a y-intercept of $\frac{V_{max}}{K_m}$, and this is called an Eadie-Hofstee plot. It should perhaps be noted that K_m has units of concentration.

Inhibitors are very important in studying enzymes. Information about the enzyme's catalytic action can be obtained using different inhibitors. In many cases, kinetic studies with inhibitors can be informative. Two important kinds of inhibition are called *competitive* and *non-competitive*. Competitive inhibitors act by competing with the substrate for the binding site on the enzyme. Non-competitive inhibitors may interact with the enzyme at the substrate binding site, or may bind elsewhere to the enzyme, or may bind the ES complex. The kinetic characteristics of the two types of inhibition are different. Equations can be derived from Michaelis-Menten considerations, taking inhibition into account. These can be arranged to yield straight line forms which indicate the changes expected in the presence of different types of inhibitors. Competitive inhibitors increase K_m and leave V_{max} unchanged, while with non-competitive inhibitors, V_{max} is altered but K_m remains unchanged. A Lineweaver-Burk plot illustrating this behavior is shown in Figure 1.19. It may be noted from the figure that the change

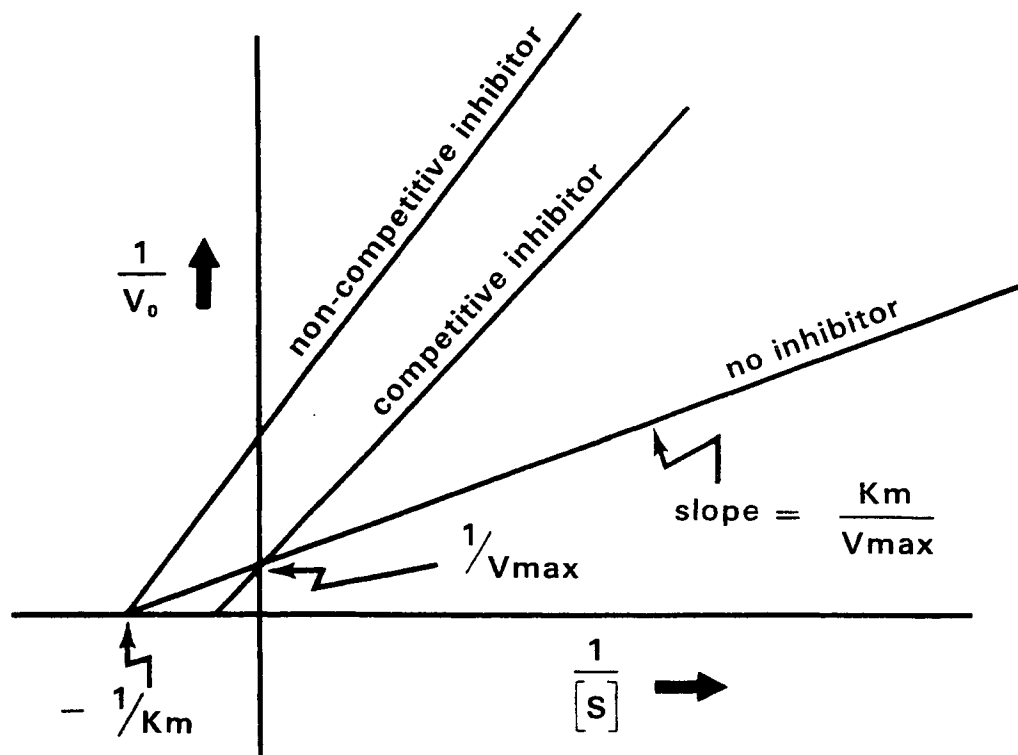


Figure 1.19 Lineweaver-Burk Plot Showing Hypothetical Curves for Enzyme Catalyzed Reaction and Behavior With Competitive and Non-competitive Inhibitors

in K_m or in V_{max} brought about by the inhibitors is equivalent to

$$1 + \frac{[I]}{K_i}$$

where $[I]$ represents inhibitor concentration and K_i is a dissociation constant for the reaction of enzyme with inhibitor: $E + I \rightleftharpoons EI$. Mahler and Cordes (1971) may be consulted for a more detailed treatment of enzyme kinetics.

1.1.3.4 Enzyme-catalyzed reactions and cofactors. The essential feature of enzyme-catalyzed reactions is their specificity. In some cases, the specificity is absolute, but in others, it is broader. Specificity is based on the fact that an enzyme contains a particular constellation of a few amino acid residues in the structure, ordered in space in a particular way. This "active site" recognizes the substrate molecule. Originally, it was thought that the special configuration of the active protein was rigid, and that substrate recognition and binding represented a kind of "lock and key" affair. This explanation suffices well in cases where substrate specificity is absolute, but does not easily explain the cases in which a number of related substrates can be acted upon. Koshland's "induced fit theory" allows for more flexibility in the active site. According to this idea, approach of the substrate may induce subtle conformational changes in the protein, yielding proper orientation of the active site's residues for binding and catalysis.

Most enzymes exhibit maximal catalytic activity over relatively narrow ranges of pH. It is necessary, therefore, to

buffer solutions used for enzyme work to pH values near the pH optimum. Extremes of pH can denature enzymes. Similarly, many enzymes do not survive extremes of temperature very well. The behavior of enzymes under various conditions varies widely though. The environment of the enzyme has a good deal to do with its stability. Purified enzymes may be denatured under conditions different from those which would denature the enzyme *in vivo*, and conversely. Many isoenzymes of the red cell are active in lysates that have been frozen. Similarly, dessication alone does not denature many red cell enzymes irreversibly, because these can be determined from dried blood stains. It is true that very little is known about the detailed changes which the proteins undergo in being dessicated, and later reconstituted.

Many enzymes depend on the presence of an additional molecule or atom for their catalytic activity. These additional molecules are called *cofactors*. Sometimes, a simple ion such as Zn^{++} or Cl^- is required for activity, while in other cases the cofactor is an organic molecule. The organic cofactors, many of which are derived from vitamins, are sometimes called *coenzymes*. In the jargon of biochemistry, the enzyme protein without its cofactor is called the apoenzyme, and the intact catalytic unit, protein plus cofactor, is called the holoenzyme. Some cofactors can be quite readily dissociated from the protein, while others are very tightly bound. A few of the more common cofactors, and the types of reactions in which they are involved, are indicated in Table 1.2.

Table 1.2 Coenzymes

Coenzyme	Type of Reaction
Nicotinamide Adenine Dinucleotide (NAD)	Oxidation-Reduction
Nicotinamide Adenine Dinucleotide Phosphate (NADP)	Oxidation-Reduction
Flavin Adenine Dinucleotide (FAD)	Oxidation-Reduction
Coenzyme A	Activation and Transfer of Acyl Groups
Thiamine Pyrophosphate	Acyl Group Transfer
Biotin	Carbon Dioxide Fixation
Pyridoxal Phosphate	Transamination of Amino Acids

1.1.4 Metabolism

Metabolism refers to the sum total of all the reactions participating in the life of an organism in all their particulars. Sometimes, metabolism is subdivided into anabolism, or synthetic reactions, and catabolism, or degradative reactions. Anabolic pathways generally require energy, while catabolic ones generally liberate it.

Metabolic pathways will not be discussed here. Many good standard texts and reviews are available on the subject, which is enormously complex. Some comments on the metabolic roles of enzymes and other compounds discussed in subsequent units are included in those sections.

1.2 Genetics

1.2.1 Introduction

The science of genetics as an independent field of inquiry has developed almost in its entirety in the present century. The first systematic experiments from which constructive conclusions could be drawn on the nature of inheritance were carried out in a monastery in Brunn (now Brno, Czechoslovakia) by Gregor Mendel (1822-1884). The now classical experiments, carried out on garden pea plants, occupied about 8 years, being communicated to the local scientific society in 1865 (Mendel, 1865). The original paper was translated by the Royal Horticultural Society, and was published by Bateson (1909) with modifications and notes. It is reprinted in Peters (1959). For reasons which are not altogether clear, no notice was taken of Mendel's work until 1900, when the European botanists, Correns, Tschermak and deVries, confirmed Mendel's original results. Some authors have marked 1900 as the year in which Mendel's work was "rediscovered." At least a part of the credit for bringing the work, and its confirmation by others, to the attention of the British scientific community must go to Bateson (Carlson, 1966). Bateson became quite interested in Mendel and his work, and Bateson's book, published in 1909, is an excellent source of material on the subject. Mendel was primarily a teacher until 1868, when he became abbot, or "Prälat," of his monastic community. He does not appear to have had much time to devote to his experiments after that time. Among other things, he became embroiled in a dispute with the government over an 1872 law which imposed taxes upon the property of religious houses. During the last decade of his life, he is said to have been bitter and disappointed over a number of matters. He is known to have been deeply disappointed by the fact that the results of his work were largely neglected by scientific colleagues. He wrote a number of letters to Nägeli, a leading naturalist, but was apparently unable to interest him in the discoveries. Bateson (1909) speculated that he may not have made any further efforts. Mendel is known to have done other sets of experiments too, most notably on heredity in bees, but the notes and records he was known to have kept were never found.

The term "genetics" was coined by Bateson in 1905 in a letter he wrote to Sedgwick (Carlson, 1966). The term "gene" to represent the discreet units of heredity, which had

been revealed by Mendel's studies, was coined by Johannsen in 1909 (Carlson, 1966). Throughout the first twenty-five years of the 20th century, an understanding of the principles underlying inheritance, and many of their complexities, was gradually reached. The names of William Bateson, R. C. Punnett, G. H. Hardy, W. Weinberg, T. H. Morgan, A. H. Sturtevant, Sewall Wright, H. J. Muller and C. B. Bridges, and many others are associated with this work. Morgan won the Nobel Prize in 1933 "for his discoveries concerning the role played by the chromosomes in heredity"; Muller was likewise honored in 1946 "for his discovery of the production of mutations by means of X-ray irradiation."

1.2.2 Gene action at the biochemical level

1.2.2.1 Development of the one gene-one enzyme hypothesis—the beginning of present day understanding. The behavior of the "genes" in genetic experiments, various types of inheritance, and the chromosomal basis of inheritance, will be considered in later sections. In this section is considered the development of biochemical genetics, which involves the chemical nature of the genetic material and the way in which genes act at the molecular level.

The earliest investigations on the role of genes in metabolism were carried out by an English physician, Archibald E. Garrod. He studied a number of defects, including albinism, cystinuria and alcaptonuria. In 1902, when he directed his attention to the problem, more information was available about alcaptonuria than about the others. Alcaptonuria is a rare condition, harmless for the most part, and characterized by the fact that the urine of affected persons would change to dark colors upon standing. It was clear from the information on marriages which had produced alcaptonuric offspring that the incidence was much higher in cases of first cousin marriages. Garrod was also inclined to believe that the condition was caused by some alteration in normal metabolism. By 1908, when he delivered the Croonian lectures, Garrod was suggesting that a number of these rare anomalies could be grouped together under the heading of "inborn errors of metabolism." They appeared to be inherited as recessive traits according to Mendel's laws and, although little was known about enzymes or metabolism, he appeared to think that metabolism was represented by interdependent, sequential series of reactions, and that specific enzymes played a role in these reactions. It would be several decades before the significance of Garrod's thinking was fully appreciated. Despite the Croonian lectures, and some interest on the part of others, biochemists did not take much interest in genetics until much later. Garrod published a book on "inborn errors of metabolism" in 1923. We know now that alcaptonuria is indeed an "inborn error of metabolism", namely the absence of homogentisic acid oxidase, and that it is controlled by a simple Mendelian recessive gene. Homogentisic acid (2,5-dihydroxyphenylacetic acid) is an intermediate in phenylalanine and tyrosine catabolism. Absence of the enzyme causes an accumulation of the compound, which is excreted in urine. A related inborn error, and one with far more serious consequences, is phenyl-

ketonuria (PKU). Inherited as a Mendelian recessive, this condition is caused by the absence of phenylalanine hydroxylase, the enzyme which converts phenylalanine to tyrosine. Unless this condition is detected at birth, and treated promptly by withholding phenylalanine from the diet, irreversible mental retardation is inevitably the result. PKU was discovered by Fölling in 1934.

It was not until 1941 that the first experimental evidence was put forth that genes have directly to do with specific enzymes in biochemical pathways. Beadle and Tatum (1941), using the mold *Neurospora*, could relate the presence of specific mutant genes in the organism, which affected their ability to synthesize vitamins, to the synthetic pathway involved. Studies on *Neurospora* were continued and biochemical and genetic studies were quickly extended to bacteria by Lederberg and others. These studies led to the development of what has been called the one gene-one enzyme hypothesis. In these terms, genes act by exercising control over specific biochemical reactions, and they do so by controlling the specific enzymes which catalyze those reactions. In 1958, Beadle and Tatum were awarded the Nobel Prize "for their discovery that genes act by regulating definite chemical events"; Lederberg shared the award "for his discoveries concerning genetic recombination and the organization of the genetic material in bacteria".

Our current conception of the "gene" is somewhat more well defined in terms of what has been learned about how the genetic material controls protein synthesis. The *gene* may be thought of as a linear segment of DNA, specifying the synthesis of a polypeptide chain. In many cases, more than one such polypeptide chain is required to form a complete, functional product (protein), and thus, more than one gene can be involved in the synthesis of a particular protein. It is known, particularly from studies in bacteria and viruses, that a *gene* may consist of two or more lesser segments of DNA, linearly arranged to form the "gene", but distinguishable in certain kinds of genetic tests. These units are called *cistrons*, because the genetic test used to characterize them is called a "cis-trans" test.

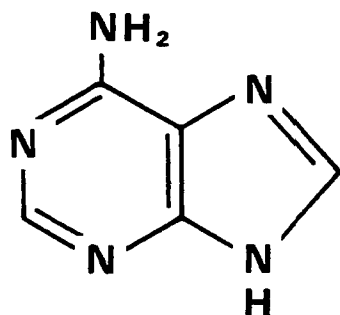
1.2.2.2 Evidence that DNA is the genetic material. Our present understanding of gene action is based on the work of many investigators. Important pieces of information which were necessary to understand the complete mechanism were: (1) DNA is the genetic material; (2) the chemical structure of DNA; (3) the fact that proteins are not synthesized directly from DNA but from a complementary RNA molecule; and (4) the mechanism by which nucleic acid sequences can specify amino acid sequences.

Evidence that deoxyribonucleic acid (DNA) is the genetic material came from several investigators' results. In 1928 Griffith observed that virulent and non-virulent types of *Pneumococcus* could be transformed in some way, one into the other, within an animal. Heat-killed virulent type bacteria (which were no longer virulent) were injected into animals along with living, non-virulent type bacteria. Many of the animals died, and living, virulent type bacteria could be recovered from the survivors. Some principle in the heat-

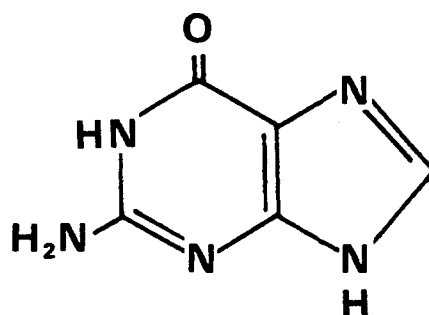
killed virulent type bacteria was thus capable of transforming the living, non-virulent type into virulent type. Later experiments showed that this transformation could be effected *in vitro* as well. The now classical experiments of Avery, McLeod and McCarty (1944) demonstrated that the "transforming principle" was in fact DNA. Another important study was done by Hershey and Chase (1952) with bacteriophages. These viruses infect bacteria, and utilize the bacterial cell's biochemical machinery for their own reproduction. The phage consists of DNA (or sometimes RNA) in a "core," and a protein "coat." By labelling the protein and the DNA with different radioactive tracer atoms, Hershey and Chase could show that it was the nucleic acid which entered the bacterial cell, and that it, and not the protein, was thus the component required for the production of genetically identical viruses.

1.2.2.3 Structure of DNA and RNA. Nucleic acids are polymers of nucleotides. Nucleotides are molecules consisting of one of five nitrogenous bases, a five-carbon sugar, and phosphate. The nitrogenous bases which occur in nucleic acids are of two types, purines and pyrimidines. The purines are adenine and guanine; the pyrimidines are thymine, cytosine and uracil (Fig. 1.20). The names of the bases are sometimes abbreviated to the first letter of the name, A, G, T, C and U. The five carbon sugar may be ribose or deoxyribose (Fig. 1.21). Ribose containing nucleotides make up RNA while deoxyribose containing nucleotides make up DNA. The purines and pyrimidines can be linked to either of the sugars in the absence of phosphate forming molecules called *nucleosides*. The structures of two of the ten possible nucleosides, deoxyadenosine and thymidine, are shown in Fig. 1.22. Note that the purine or pyrimidine ring structures are numbered conventionally, while the sugar ring positions are indicated by primed numbers. Phosphoric acid can be esterified to the nucleosides through the 3'-position in the sugar residue, the resulting nucleoside phosphates being called nucleotides. The nucleotides corresponding to the nucleosides shown in Fig. 1.22 are shown in Fig. 1.23. Esterification at the 5' position occurs as well. Table 1.3 gives the names of the bases, and the nucleosides and nucleotides formed from each of them for both ribose and deoxyribose forms.

Nucleotide residues may be linked together by sugar-phosphate-sugar bonds to form polynucleotide chains. Long polynucleotide chains are known as nucleic acids. The structure of a deoxyribose polynucleotide chain is shown in Fig. 1.24. Note that the phosphodiester bonds holding the nucleotides together link the 3' carbon of one sugar residue to the 5' carbon of the next, and so forth. With some exceptions, which will not be gone into, RNA usually consists of one chain, of the kind shown in Fig. 1.24, except that the sugar is ribose. RNA does not usually contain thymine nucleotides. DNA does not contain uridine nucleotides. The structure of DNA is more complicated than that of RNA because it usually involves two chains, or strands. It consists, as mentioned already, of A, C, T and G nucleotides. Chargaff found that in DNA from mammalian sources, the

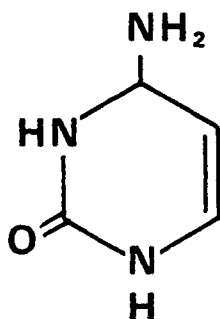


Adenine (A)

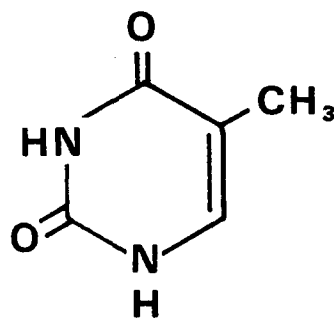


Guanine (G)

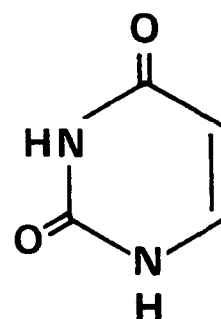
Purines



Cytosine (C)



Thymine (T)



Uracil (U)

Pyrimidines

Figure 1.20 Purine and Pyrimidine Bases

amount of A was the same as that of T, while the amount of C was the same as that of G. The $\text{A} + \text{T} / \text{C} + \text{G}$ ratio did vary in DNA from different sources. Data from X-ray diffraction studies by Wilkins and Franklin and the information from chemical studies enabled Watson and Crick to postulate a structure for DNA in 1953. This structure, the now well-known double helix, is the usual structure of DNA. Watson, Crick and Wilkins shared the Nobel Prize in 1962

“for their discoveries concerning the molecular structure of nucleic acids and its significance for information transfer in living material”. The double helix is constructed from two polynucleotide chains. They are held together by hydrogen bonds which occur between A and T and between C and G. The structure is shown diagrammatically in Fig. 1.25. Note that the direction in which the $3' \rightarrow 5'$ phosphodiester bonds run is reversed in the two complementary chains, as indi-

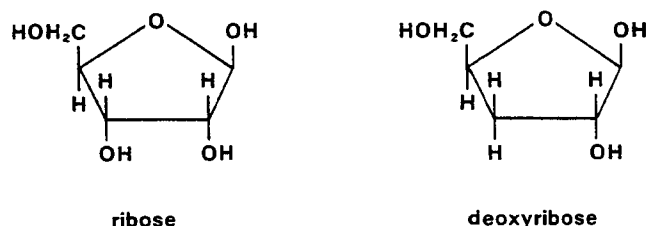


Figure 1.21 Ribose and Deoxyribose Sugars

(3) semiconservative mechanism, in which the double stranded molecule separates into single strands, and each acts as a template for the synthesis of a new complementary strand. In 1958, Meselsohn and Stahl carried out their now classical experiments on DNA replication, and proved that the mechanism was semi-conservative. The process is indicated diagrammatically in Fig. 1.27. The cell free synthesis of DNA from single stranded templates and nucleotide precursors in 1956 was completely consistent with what was already known (Kornberg *et al.*, 1956; Kornberg, 1959). He

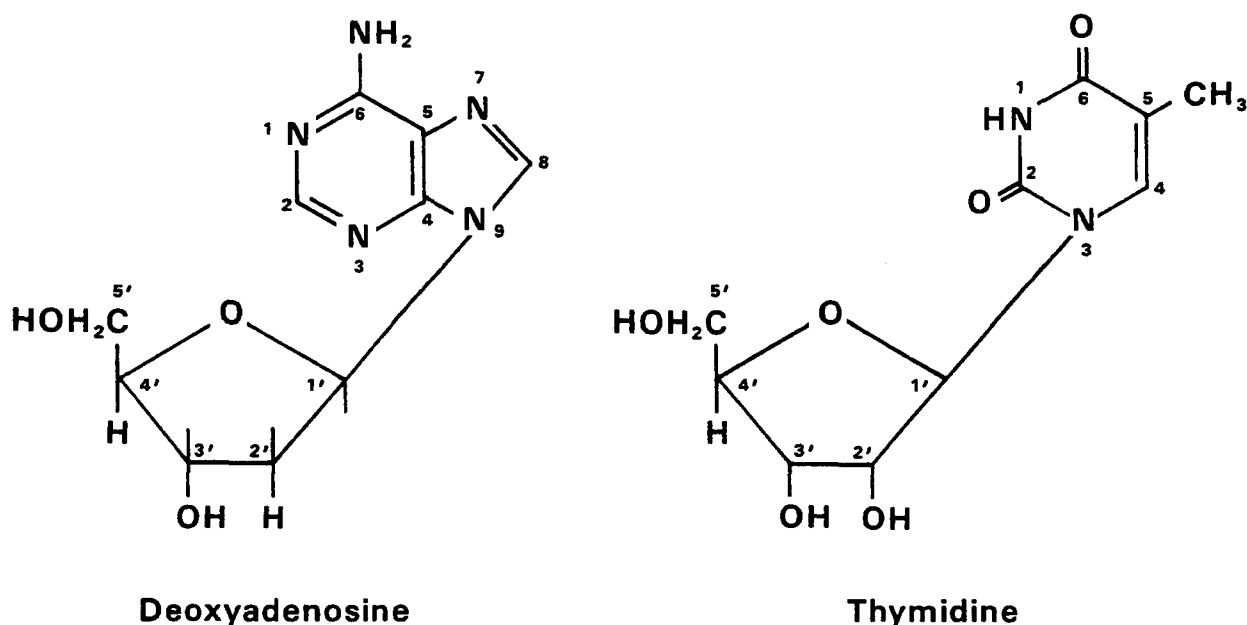


Figure 1.22 Nucleosides

cated by the arrows. Three dimensionally, the molecule is in a helical configuration, one helical chain being wound about the other (Fig. 1.26).

1.2.2.4 Replication of DNA. DNA replicates during cell division, yielding exact copies of the parent molecules. The structure must allow for a mechanism by which this replication can take place. In theory, there are three mechanisms by which the molecule could replicate: (1) dispersive mechanism, in which the molecule was broken up into small fragments, the small fragments replicated, and the larger molecules then somehow reassembled; (2) conservative mechanism, in which the entire double stranded molecule acts as a template for the synthesis of daughter chains; and

received the Nobel Prize in 1959, along with Ochoa, "for their discovery of the mechanisms in the biological synthesis of ribonucleic and deoxyribonucleic acid."

1.2.2.5 RNA, Protein synthesis and the genetic code. There are three types of RNA in cells: messenger RNA (m-RNA), ribosomal RNA (r-RNA), and transfer RNA (t-RNA). The last-mentioned is also called soluble RNA (s-RNA). Messenger RNA serves as the actual template for protein synthesis. It is synthesized enzymatically from one of the strands of DNA, the sequence of the m-RNA being complementary to that of DNA, in accordance with the base pairing rules. In effect, the complementary bases of RNA nucleotides bind to the bases of

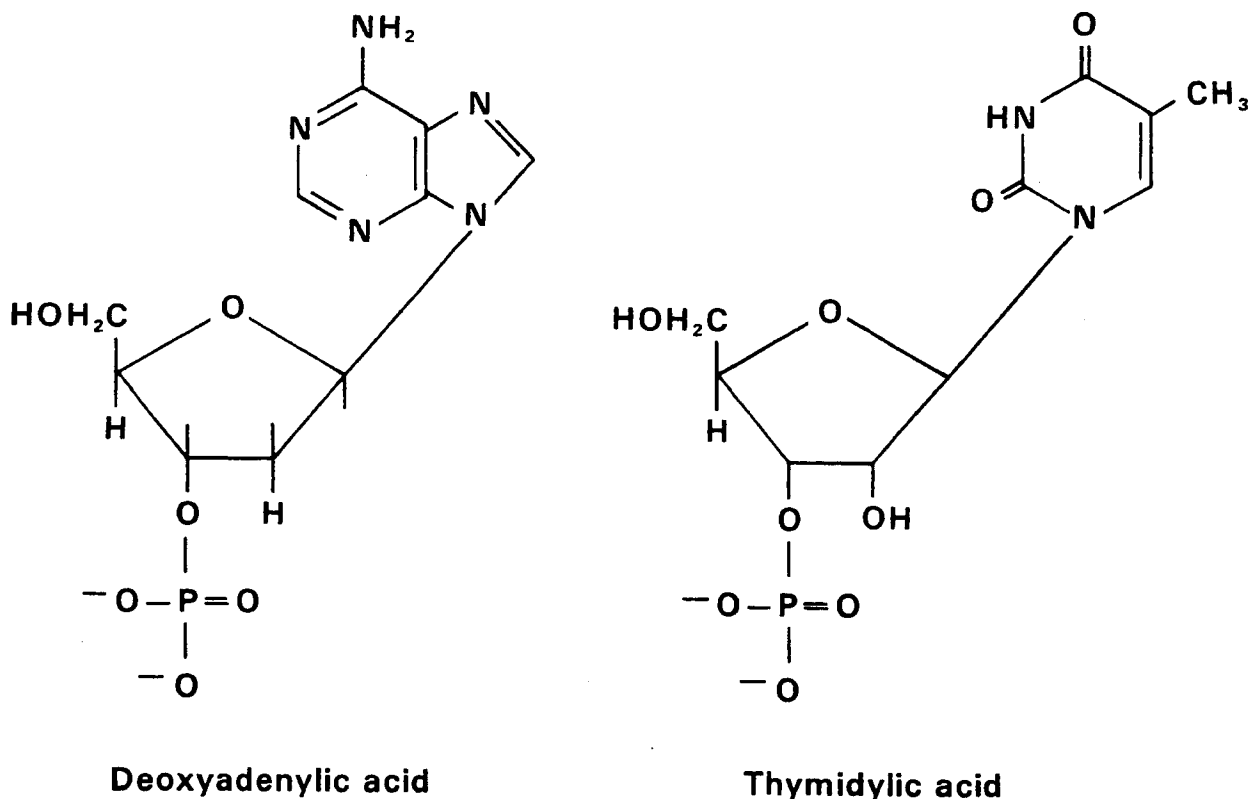


Figure 1.23 Nucleotides

the nucleotides within the DNA strand, and are then enzymatically linked. An A in DNA calls for a U in the complementary RNA, a T in DNA for an A in RNA, a C in DNA for a G in RNA and a G in DNA for a C in RNA. The A-T (A-U) and C-G base pairing serves to align the ribonucleotides on the DNA template. This is illustrated in Fig. 1.29.

Ribosomal RNA is, as the name implies, an integral component of the ribosome, the cytoplasmic site of protein synthesis. Ribosomes are composed of two subunits, and contain protein in addition to the r-RNA. The precise details of ribosome function are not yet fully understood, but in general, the ribosome functions to associate m-RNA, amino acids and the appropriate enzymes into configurations suitable for protein synthesis to take place.

Transfer-RNA molecules are the smallest of the ribonucleic acids. They provide the link between the amino acid and the appropriate nucleotide sequences in m-RNA, serving, in effect, as adapter molecules. There are a number of different t-RNA molecules in the cell, at least one for each of the amino acids which occurs in proteins, and some others which carry out specialized functions. In 1965, Holley *et al.* published the complete sequence of alanine-t-RNA. The structure is shown in Fig. 1.28. There is much evidence to

support the "cloverleaf" conformation of the molecule shown in the figure.

During the 1960's, the mechanism of protein synthesis was worked out. It became clear that the amino acid sequence of the protein was specified by the base sequence in the m-RNA which had, in turn, been specified by the base sequence in DNA. There are four bases in RNA, and we now know that a linear sequence of three bases in the chain is required to specify an amino acid. The "code word", or *codon*, therefore, is a triplet. Nirenberg and his collaborators did many of the experiments which resulted in the assignment of the codons. The polynucleotides of known sequence, synthesized by Khorana and his associates, also figured importantly in this work. Nirenberg, Khorana and Holley jointly received the Nobel Prize in 1968 "for their interpretation of the genetic code and its function in protein synthesis."

Using the four bases of RNA to form triplets allows for 64 codons. Since there are only 20-odd amino acids, the *genetic code*, as it is called, is degenerate, i.e., there can be more than one codon for a particular amino acid. It is now known that the code is non-overlapping, and does not contain "punctuation." By non-overlapping is meant that the code is read in strictly linear order, three bases at a time. The se-

Table 1.3 Naming of Bases, Nucleosides and Nucleotides

Base	Ribonucleoside	Ribonucleotide	Deoxyribonucleoside	Deoxyribonucleotide
Adenine	Adenosine	Adenylic acid	Deoxy-adenosine	Deoxyadenylic acid
Guanine	Guanosine	Guanylic acid	Deoxy-guanosine	Deoxyguanylic acid
Cytosine	Cytidine	Cytidylic acid	Deoxy-cytosine	Deoxycytidylic acid
Thymine	Thymidine	Thymidylic acid	Deoxy-thymidine	Deoxythymidylic acid
Uracil	Uridine	Uridylic acid	Deoxy-uridine	Deoxyuridylic acid

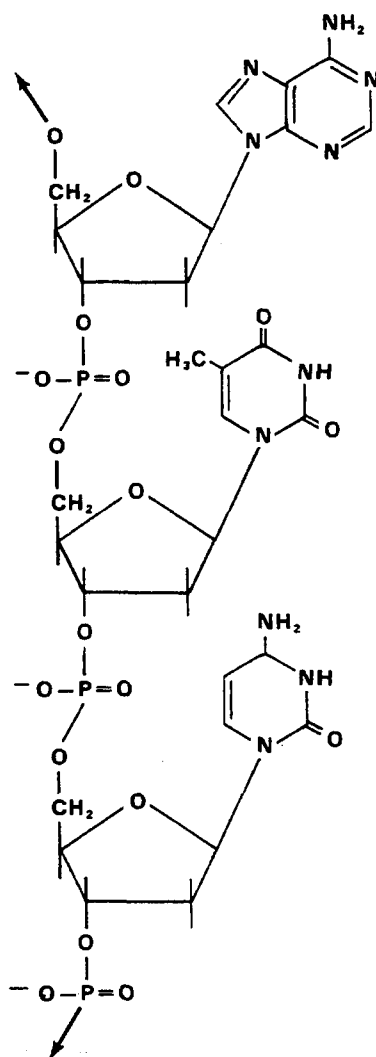


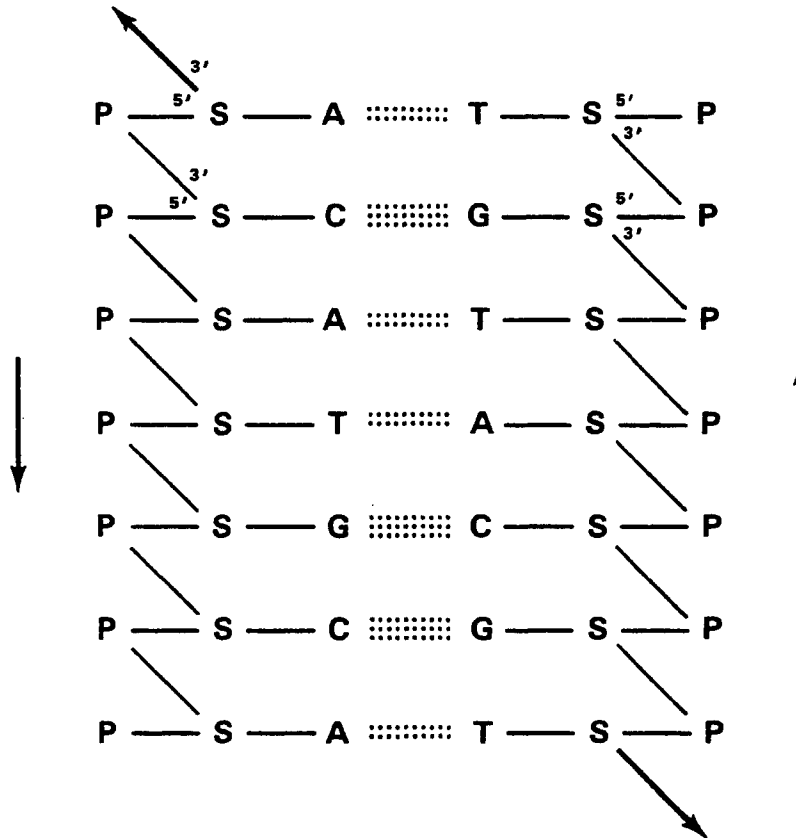
Figure 1.24 A Deoxyribose Polynucleotide Chain

quence AUGUUUGGA, for example, is read AUG UUU GGA, and *not* as AUG UGU GUU, or as AUG GUU UUG, etc. The overall scheme is indicated diagrammatically in Fig. 1.29. Transfer-RNA's are able to bind to particular amino acids. In addition, they possess a trinucleotide sequence in their structure which "recognizes" the m-RNA codon by base pairing, i.e., is complementary to the codon. This trinucleotide sequence in the t-RNA is called the *anti-codon*. Therefore, to say that UUU codes for phenylalanine is to say that Phe-t-RNA has the anticodon sequence AAA which can base pair (bind) the UUU codon. The genetic code is shown in Table 1.4. There are codons which call for initiation of protein synthesis as well as those which call for termination.

The process of protein synthesis is quite a bit more complicated than has been outlined here. Many of the details have been omitted for the sake of brevity. Further information on the subject may be found in Levine (1968), Watson (1976), Zubay (1968) and Zubay and Marmur (1973), and in many textbooks.

1.2.3 Chromosomes

The DNA of the cell is organized in the nuclear chromosomes. The behavior of the chromosomes can be observed microscopically. Cell division is the fundamental process by which cells make exact copies of themselves. In unicellular organisms, cell division is equivalent to reproduction, and in multicellular organisms, cell division is required for growth and differentiation. Sexually reproducing organisms carry out a specialized kind of cell division in order to produce gametes, or sex cells. There are, thus, two important kinds of cell division. The first, *mitosis*, is a process in which a cell divides to produce genetically equivalent daughter cells. The second type, *meiosis*, is characteristic of sexually reproducing organisms, and represents the process by which gametes are formed. The gametes contain half the number of chromosomes of other cells in the organism, the original number of chromosomes being restored at fertilization,



**Figure 1.25 Double-stranded DNA. S = deoxyribose sugar
P = phosphate A,C,T,G = purine and pyrimidine
bases :::: = hydrogen bonds.**

when the gametes combine. The gamete contains in its chromosomes a random half of the genetic information from the parent from whom it is derived. All species contain a characteristic number of chromosomes, and chromosomes occur in pairs. The two members of a pair are said to be *homologous*. The total number of chromosomes is called the diploid ($2n$) number. Half that number, the number found in gametes, is called the haploid (n) number.

1.2.3.1 Mitosis. Mitosis or cell division is usually divided into a number of phases. The process is represented diagrammatically in Fig. 1.30. The terminology used to describe mitotic phases is not important to this discussion. The essential features of the process are the pairing of homologous chromosomes, their replication, and their arrangement in such a way that a complete set of chromosomes is drawn to opposite poles of the dividing cell. Upon division of the cytoplasm, each daughter cell contains a complete set of chromosomes, exact copies of the original set.

1.2.3.2 Meiosis. Meiosis is the process by which sexually reproducing organisms form their gametes. It is similar to mitosis in many respects, but results in four instead of two products, each of which possess a haploid number of chromosomes. The process is illustrated diagrammatically in Figure 1.31. Meiosis differs from mitosis in that homologous chromosomes pair and replicate, but there are then two successive cellular divisions, resulting in four cells, each of which possesses one member of each of the original pair of chromosomes. Gametes are therefore haploid cells. At fertilization, the diploid number of chromosomes is restored in a single cell (the fertilized egg, or zygote), and the chromosome number characteristic of the species is maintained and conserved.

1.2.3.3 Human chromosomes and sex determination. For a long time it was believed that human beings had a diploid number of 48 chromosomes. In 1956, Tjio and Levan carefully examined cells in tissue culture, and found

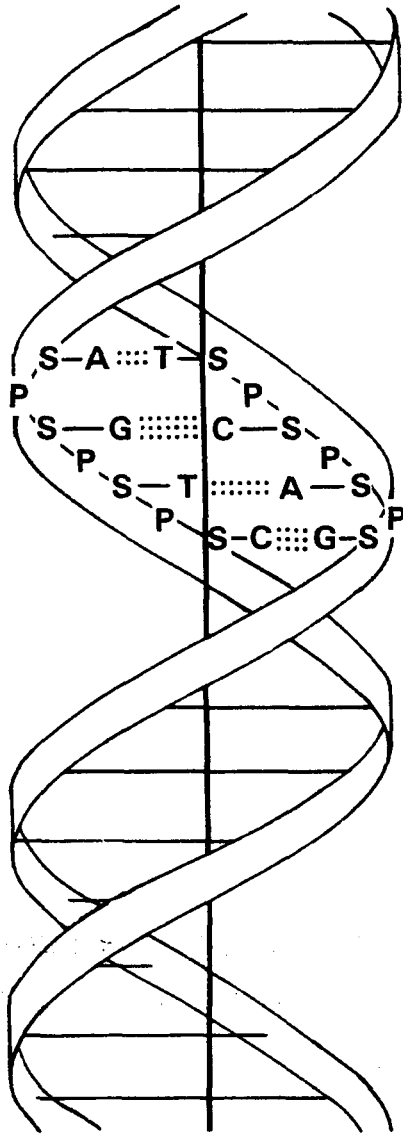


Figure 1.26 Double helical DNA

that the diploid number is, in fact, 46. 44 of these chromosomes consist of 22 homologous pairs, and these are usually called *autosomes*. The remaining two chromosomes in a given person may be either a pair of X-chromosomes, or an X and a Y chromosome. The X and Y are called *sex chromosomes*. XX people are female, while XY people are male. With a few bizarre exceptions in which hormonal or other factors seem to play a major role, sex in human beings is chromosomally determined. Females are XX and ova always contain an X chromosome in addition to 22 autosomes after meiosis. Males are XY, and meiosis gives rise to an equal number of X-bearing and Y-bearing sperm. The sex of the offspring is determined, therefore, by whether an X- or Y-bearing sperm cell fertilizes the ovum.

There are a number of chromosomal aberrations in humans. With present-day cytogenetic techniques, a few cells can be removed from an individual, grown in tissue culture, and used to prepare good, stained preparations in which the chromosomes are visible under the microscope. If a photomicrograph is then made and enlarged, the pictures of the chromosomes can be cut out, classified, and arranged in order to see if chromosomal abnormalities are present. This technique is called karyotyping. Fetuses can be karyotyped *in utero* by collecting a few cells from the amnion for the culture, a procedure known as amniocentesis. One of the abnormalities that can occur in human beings is Down's syndrome, or mongolism. This condition, characterized by mental retardation, impaired motor development and decreased life expectancy, is the result of an affected individual having three, instead of two, number 21 chromosomes. The condition of having three chromosomes, where there ought to be two, is called trisomy, and Down's syndrome may be said to be the result of trisomy at chromosome 21. There are abnormalities of the sex chromosomes as well. Persons having 45 chromosomes, and only one X, are said to be XO. They are females and suffer from a kind of gonadal dysgenesis called Turner's syndrome. There are abnormal males who possess 47 chromosomes, with an XXY complement of sex chromosomes. They are said to suffer from Klinefelter's syndrome. There are many other abnormalities as well.

1.2.4 Patterns of inheritance

1.2.4.1 Simple patterns. Mendel's discoveries had to do with simple modes of autosomal inheritance. Individuals have a pair of genes which control a particular, simply inherited trait. Genes are usually represented by letters. Mendel was able to explain the results of his crosses using simple genetic models. The elegance of his findings is difficult to appreciate in view of what is known today, but nothing of the chromosomal basis of inheritance was known at the time when the experiments were done.

The *phenotype* of an organism is the way it looks with respect to a particular trait, i.e. how the gene is expressed. Thus, eye color in *Drosophila* (the fruit fly), flower color in many plants, and blood types in humans are phenotypes. The *genotype* is the gene composition of the organism for the particular trait. To state the genotype is to state which genes are actually present on the chromosomes.

Suppose a hypothetical flowering plant species. Two types are available, one with red flowers, and another with white flowers. Each of these is "breeding true", i.e. crosses among red-flowered plants always produce red flowered offspring, and similarly for the white-flowered plants. Suppose that the red flowered and white flowered plants are crossed, fairly large numbers of off-spring are obtained, and they all have red flowers. This "first filial generation" or F_1 is now crossed with other F_1 plants again yielding large numbers of plants in an F_2 generation. It is now found that there are about 3 red-flowered plants for every white-flowered plant. A simple genetic explanation for these observations is shown in Fig. 1.32. Since red appears exclusively in the F_1 , it is called

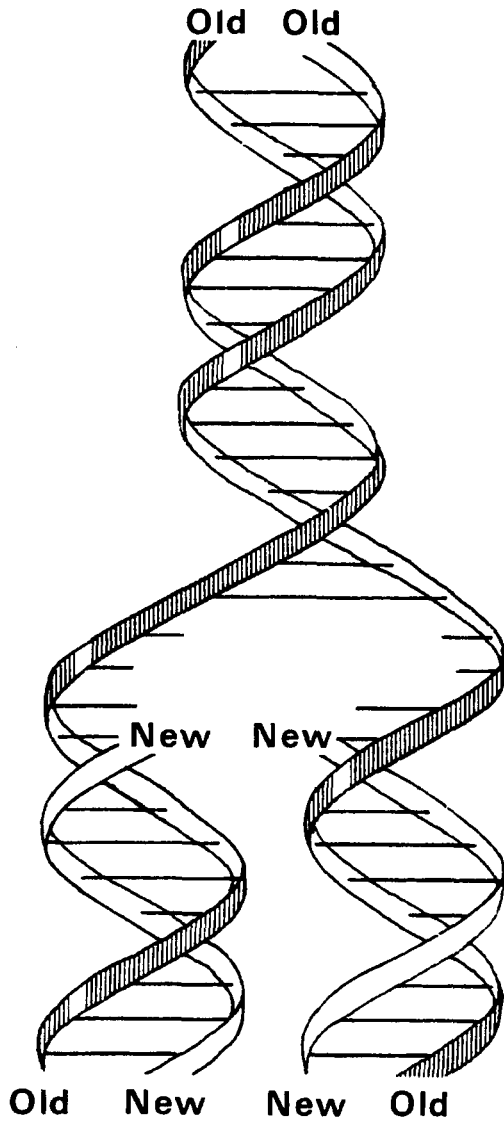


Figure 1.27 DNA Replication

dominant over white. White has not disappeared because it reappears in the F_2 . White is called *recessive* in this case. Let R stand for the gene determining red flower color and r stand for the gene determining white flower color. True breeding red flowered plants are genotypically RR while the white flowered counterparts are genotypically rr. Red plants which are RR can make only R containing gametes at meiosis and rr white flowered plants can make only r gametes. The F_1 generation must therefore be Rr genotypically, and phenotypically the flowers are red. In the $F_1 \times F_1$ cross, each plant should make an equal number of R and r gametes. Allowing fertilization to occur completely at random, i.e. R gametes fertilize R and r gametes with equal frequency, and r ga-

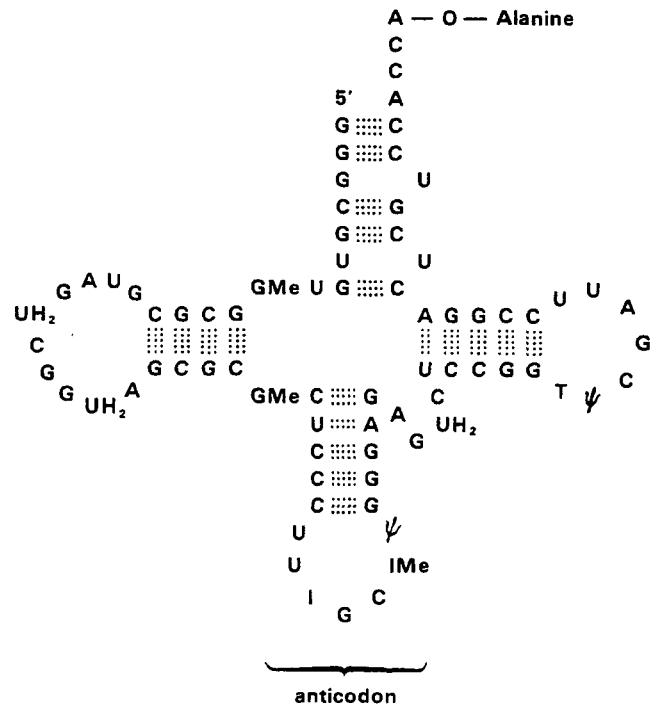


Figure 1.28 Structure of Alanine-t-RNA

metes fertilize R and r gametes with equal frequency, one can predict the genotypes of the F_2 . An easy way of doing this is to use the so-called Punnett square (Fig. 1.32). Of every four plants, 1 is expected to be RR, two Rr and 1 rr. Phenotypically, three out of four should be red flowered. This simple situation, which is quite similar to the experiment Mendel carried out, illustrates Mendel's so-called first law, the law of segregation. Simply put, it says that the members of a gene pair segregate from one another at meiosis and are distributed evenly in gametes. The members of a gene pair are often called *alleles*. In the example, R is the dominant allele, r, the recessive allele. When the genotype consists of two of the same allele, as in RR or rr in the

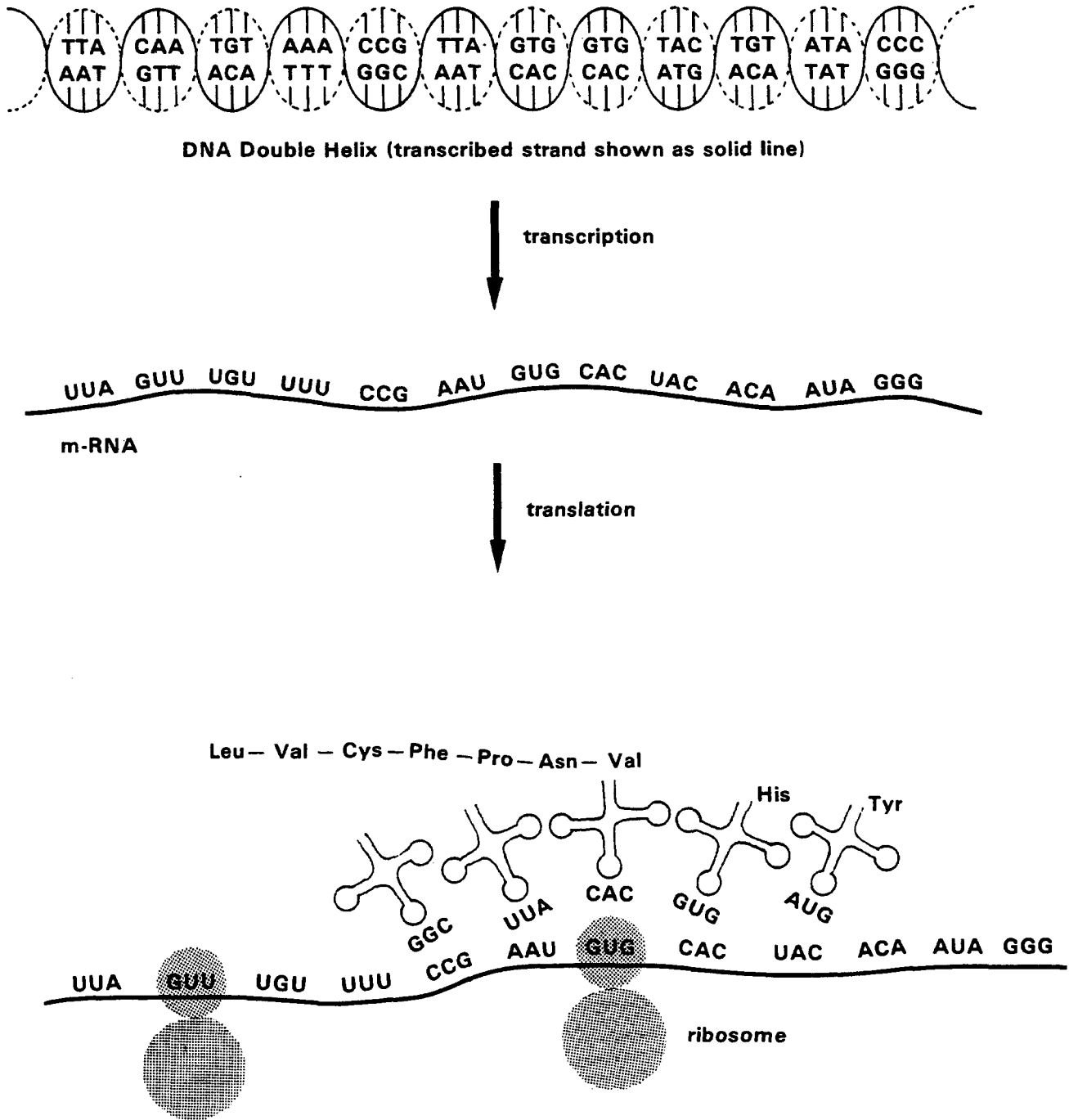


Figure 1.29 Overall Scheme of Protein Synthesis

example, the individuals are said to be *homozygous*. The red-flowered plant is homozygous dominant, the white-flowered one is homozygous recessive. The Rr genotype individual is referred to as being *heterozygous*.

Mendel's second law has to do with the segregation of the genes for two independent characteristics. Let us suppose

that our hypothetical plants have another characteristic, tallness, which is under simple genetic control. If we crossed true breeding tall plants with true breeding short plants, the F_1 would all be tall. If the members of the F_1 were self-crossed, the F_2 would have approximately 3 tall plants for every 1 short plant. Suppose the same experiment is done,

Table 1.4 The Genetic Code

UUU	Phe	UCU	Ser	UAU	Tyr	UGU	Cys
UUC		UCC		UAC		UGC	
UUA	Leu	UCA		UAA	Terminate	UGA	Terminate
UUG		UCG		UAG		UGG	
CUU	Leu	CCU	Pro	CAU	His	CGU	Arg
CUC		CCC		CAC		CGC	
CUA		CCA		CAA	CGA		
CUG		CCG	CAG	CGG			
AUU	Ileu	ACU	Thr	AAU	Asn	AGU	Ser
AUC		ACC		AAC		AGC	
AUA		ACA		AAA	Lys	AGA	Arg
AUG		ACG	AAG	AGG			
GUU	Val	GCU	Ala	GAU	Asp	GGU	Gly
GUC		GCC		GAC		GGC	
GUA		GCA		GAA	Glu	GGA	
GUG		GCG	GAG	GGG			

but that both traits are followed at the same time. Tall, red-flowered plants are crossed with short, white-flowered ones to yield an F_1 which is all tall, red-flowered (Fig. 1.33). The F_1 members are now self-crossed, and it is found that the phenotypic ratio is 9 tall, red:3 tall, white:3 short, red:1 short, white. The cross, and its genetic explanation, are shown in Fig. 1.33. This experiment illustrates the so-called law of independent assortment (Mendel's second law). This says that the segregation of the flower color genes is in no way influenced by the segregation of the tallness-shortness genes, and conversely. The Punnett square in Fig. 1.33 predicts the outcome of the $F_1 \times F_1$ cross by assuming independent assortment, and the observation of the predicted phenotypes experimentally serves as verification that the genetic hypothesis is correct.

1.2.4.2 Variable expressivity, codominance and multiple allelic systems. A substantial number of traits in a large number of organisms are inherited according to the simple patterns discussed in 1.2.4.1. In tribute to Mendel, the patterns are often referred to as "Mendelian." We can say, in the example in Fig. 1.32 that red flower color is inherited as

a simple Mendelian dominant, and that white flower color is inherited as a simple Mendelian recessive.

There are many examples of exceptions to the patterns though. The term "variable expressivity" refers to a situation in which a gene is not fully expressed in every individual having it. If, in our flower color example above, the heterozygotes (Rr) had had flowers which were not uniformly red in the F_1 , but varying degrees of pink depending upon the individual, we would say that R showed variable expressivity. Another possibility would be that RR plants have red flowers, but that Rr plants have pink flowers. In the F_2 we would have been able to distinguish the RR from the Rr plants in that case. Variable expressivity can occur in homozygotes as well, and there are numerous examples of it. A closely related concept is that of "penetrance." In the example of Rr plants exhibiting pink flower color, it would be said that in the heterozygous condition, the R gene is "incompletely penetrant."

Not all alleles show dominance-recessivity relationships. Sometimes both members of the allelic pair are expressed if present. Such genes are said to exhibit *codominance*. Very

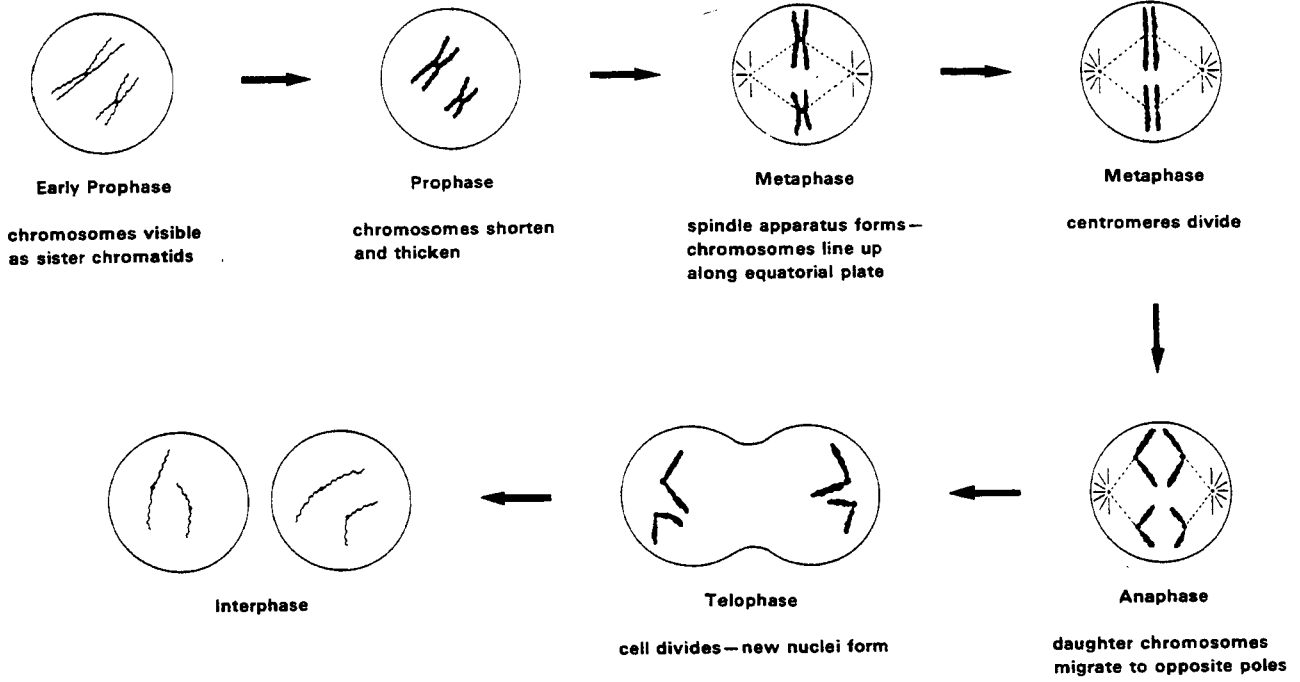


Figure 1.30 Mitosis

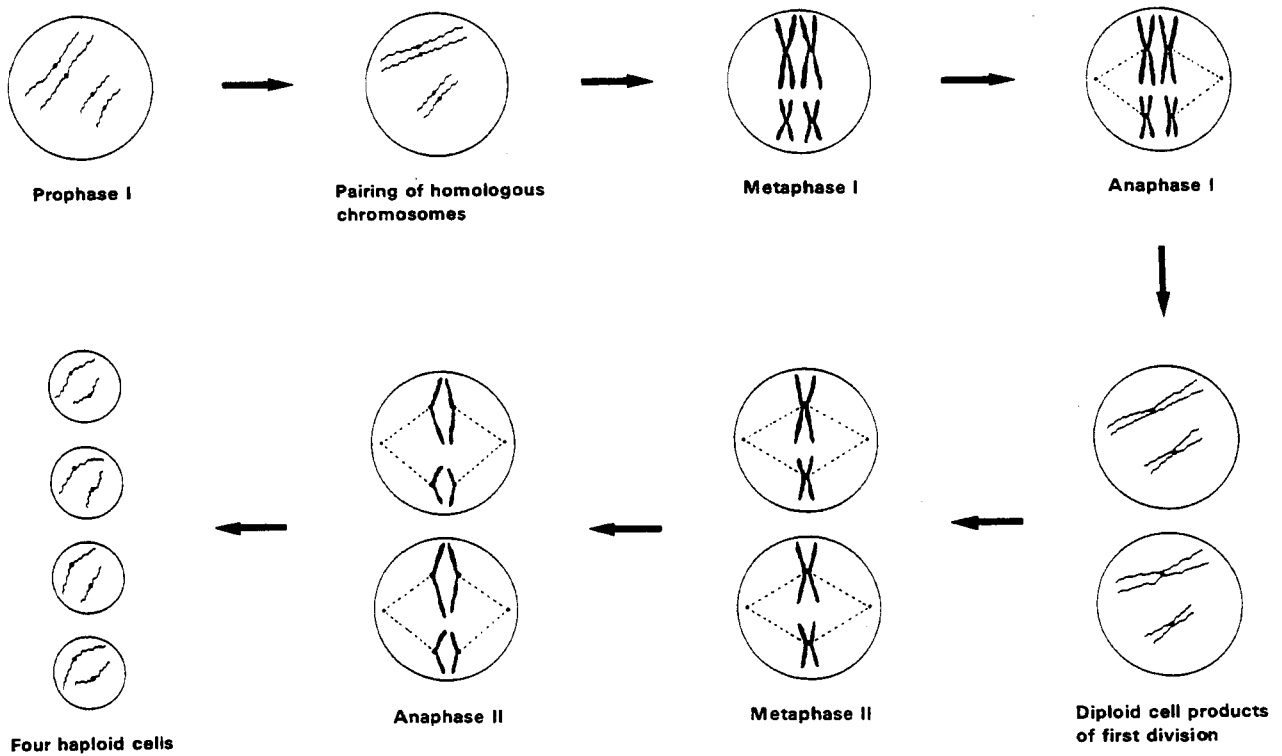


Figure 1.31 Meiosis

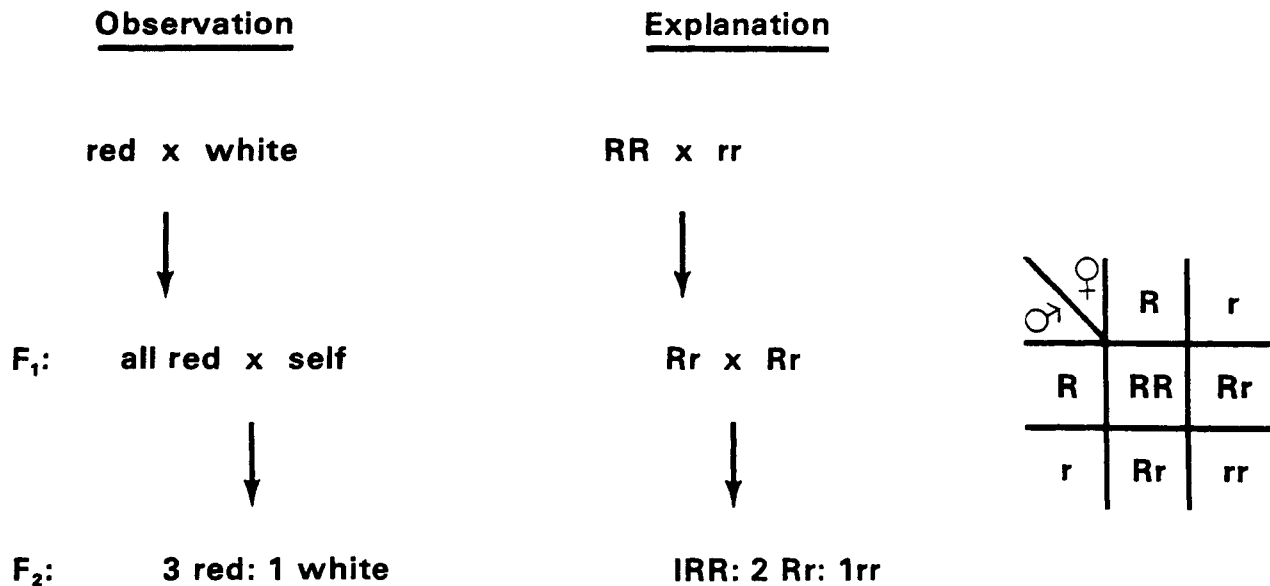


Figure 1.32 Illustration of Segregation

many of the blood group systems, isoenzyme and serum protein markers which are of great interest in legal medicine exhibit codominance. An example is the MN system. Without getting into all the complexities of the system (which will be done in Unit V), MN may be considered as a simple Mendelian codominant system. Genotypically, people can be MM, MN or NN. The heterozygotes, the MN persons, can be detected since both genes are expressed, and their red cells will be agglutinated by anti-M as well as by anti-N sera. In codominant inheritance, the genotype may be determined from the phenotype, whereas if one gene is dominant, heterozygotes cannot be distinguished from homozygous dominants. In the ABO blood group system, for example, if we call the genes for A, B and O blood groups I^A, I^B, and I^O, respectively, we cannot tell from the blood group (the phenotype) whether a person who groups as A is genotypically I^AI^A or I^AI^O.

Another important aspect of inheritance patterns is that of *multiple alleles*. The ABO blood group system provides an example. Genes are located upon the chromosomes, and it is said that the alleles controlling a particular trait are at a particular *locus* on the chromosome. In many cases, there are only two genes operating at a locus. But in many other cases, a locus can be occupied by one of several possible alleles. Such loci are said to be *multiple allelic*. In the ABO blood group system, there are three alleles. The possible genotypes are, therefore, I^AI^A, I^BI^B, I^AI^O, I^OI^O, I^BI^O, and I^AI^B. Most of the isoenzymes which will be considered in Unit VI have more than two possible alleles. In a number of

cases, there are two common alleles and a number of rarer ones.

1.2.4.3 Linkage, crossing over and genetic mapping. The term *linkage* refers to the situation in which the gene loci controlling different traits are on the same chromosome. As an illustration, let us return to our hypothetical plant with tall-short and red or white colored flowers. Suppose the same experiment is done as was done to illustrate the law of independent assortment. Red flowered, tall plants are crossed with white-flowered, short ones, and a red-flowered, tall F₁ is obtained. Upon self crossing the F₁, the F₂ shows not the 9:3:3:1 obtained previously, but 3 red flowered, tall plants to 1 white flowered, short one. This result can be explained if the flower color locus and the tall-short locus are on the same chromosome (Fig. 1.34).

The results in Fig. 1.34 are highly idealized for the sake of illustration. A much more likely outcome for the F₁ × F₁ self cross in this example would be that 80% of the F₂ progeny would be red, tall or white, short while the remaining 20% would be red, short and white, tall. The reason for the appearance of the latter two phenotypic classes brings up the subject of crossing over. Homologous chromosomes can and do exchange genetic material with one another while they are paired during meiosis. A kind of "break" occurs at a particular point along the chromosome, and the "loose ends" exchange places between the homologues. Such exchanges can be observed cytologically, and are called *chiasmata*. Fig. 1.35 illustrates crossing over in the F₁ × self cross for the example in Fig. 1.34. New combinations of loci on a

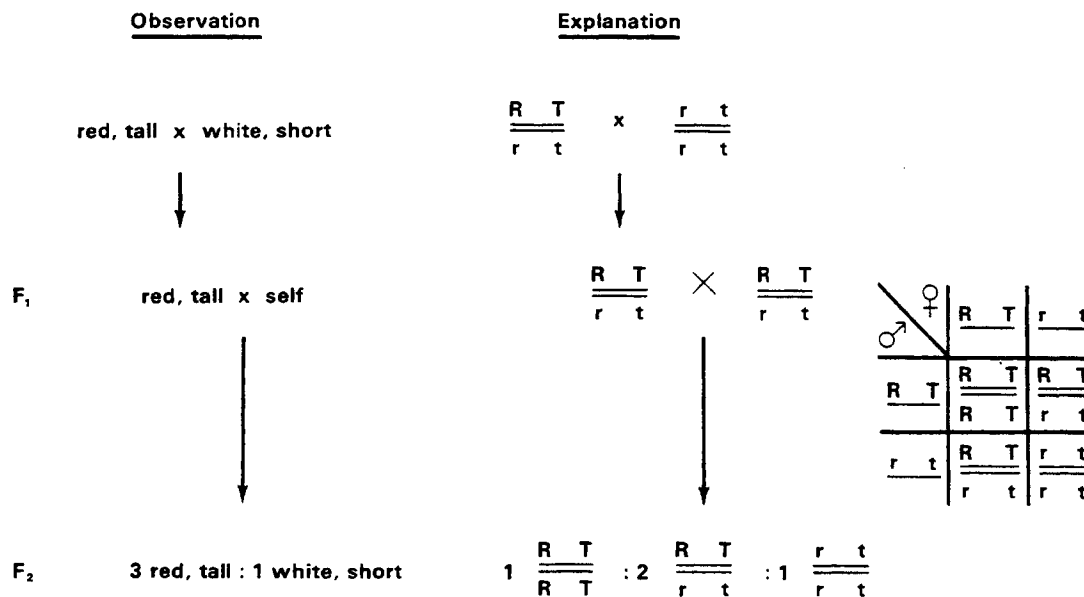


Figure 1.34 Illustration of Linkage

Y, the Y not being homologous to the X. Genes, even recessives, are therefore usually expressed in males, and are inherited from the mother. Females have to be homozygous for a recessive X-linked gene before it is expressed. Males are said to be *hemizygous* for X-linked genes.

There are genes whose expression is different in the two sexes, because of differing degree of penetrance. These are called "sex-influenced". Some genes manifest themselves only in one sex or the other, and these are called "sex-limited".

Of interest in the context of medico-legal examinations are the enzyme G6PD, the Xg blood group system and the Xm serum group system. All the evidence suggests that these are under the control of X-linked genes. McKusick (1964) should be consulted for further information about X-linked inheritance. McKusick has, in addition, compiled an extraordinary reference catalogue of genetically controlled characteristics in humans, according to whether the genes are dominant, recessive or X-linked. Each trait is assigned a catalog number, and a brief description of the characteristic is given in every case with original references. This catalog is now in its 4th edition (McKusick, 1975).

It might be supposed that the X-linked characteristics should be more intensely expressed in females who possess, in effect, a "double dose" of the gene, than in hemizygous males. In a number of cases which have been carefully examined, however, this has not turned out to be the case. Women who are homozygous for G6PD deficiency, for example, have enzyme levels closely resembling those of affected males. This phenomenon has been called "dosage compensation", compensation, as it were, for the double gene dose.

This effect is generally not seen in the case of autosomal characteristics, in which homozygotes express characteristics to about twice the extent of heterozygotes. In 1961, Lyon in England put forth an hypothesis which said that only one of the X chromosomes in each cell is actually active (Lyon, 1961, 1962a, 1962b). The decision point, at which one of the X chromosomes becomes inactivated, occurs early in embryogenesis. The descendants of a particular cell abide by the original decision, and the decision is based on chance. Thus, the same X chromosome is not inactivated in every cell. The tissues of heterozygotes would be expected on this basis to exhibit mosaicism, some cells having an active paternal X, while others would have an active maternal X. Studies on several X-linked markers have indicated the kind of somatic cell mosaicism predicted by the Lyon hypothesis. Beutler (1969) and Linder and Gartler (1965) have studied G6PD in this regard. Davidson (1968) found that markers governed by autosomal loci do not show the inactivation characteristics. Deys *et al.* (1965) studied phosphoglycerate kinase, and found the data consistent with X-chromosome inactivation. Heterozygous female subjects with Lesch-Nyhan syndrome due to a genetic absence of hypoxanthine-guanine phosphoribosyl transferase usually show two red cell populations, although in at least one case, a heterozygote for normal and mutant enzyme, the mosaicism could not be demonstrated (McDonald & Kelley, 1972). Another observation can be explained by the Lyon hypothesis, namely, the presence of so-called "Barr bodies". In 1949, Barr and Bertram noted that interphase (non-dividing) nuclei of cells from female cats contained a well-defined mass of chromatin material which is not present in males. This variation was

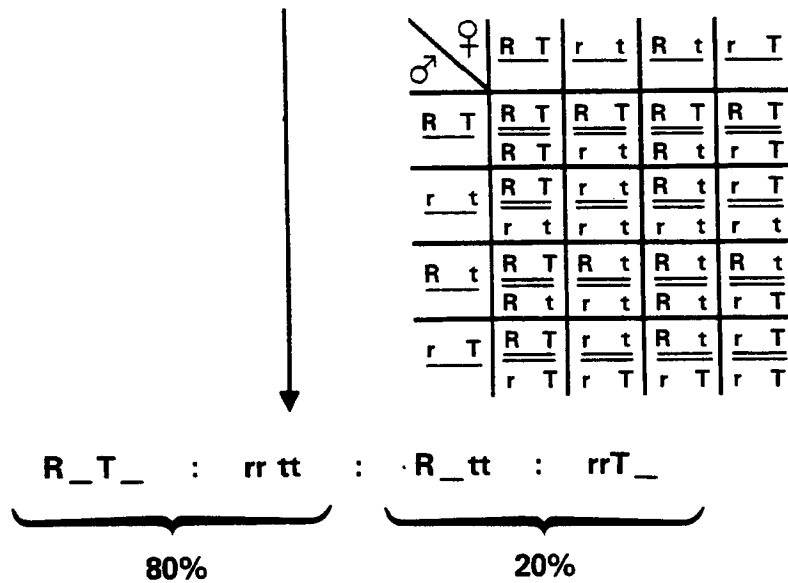
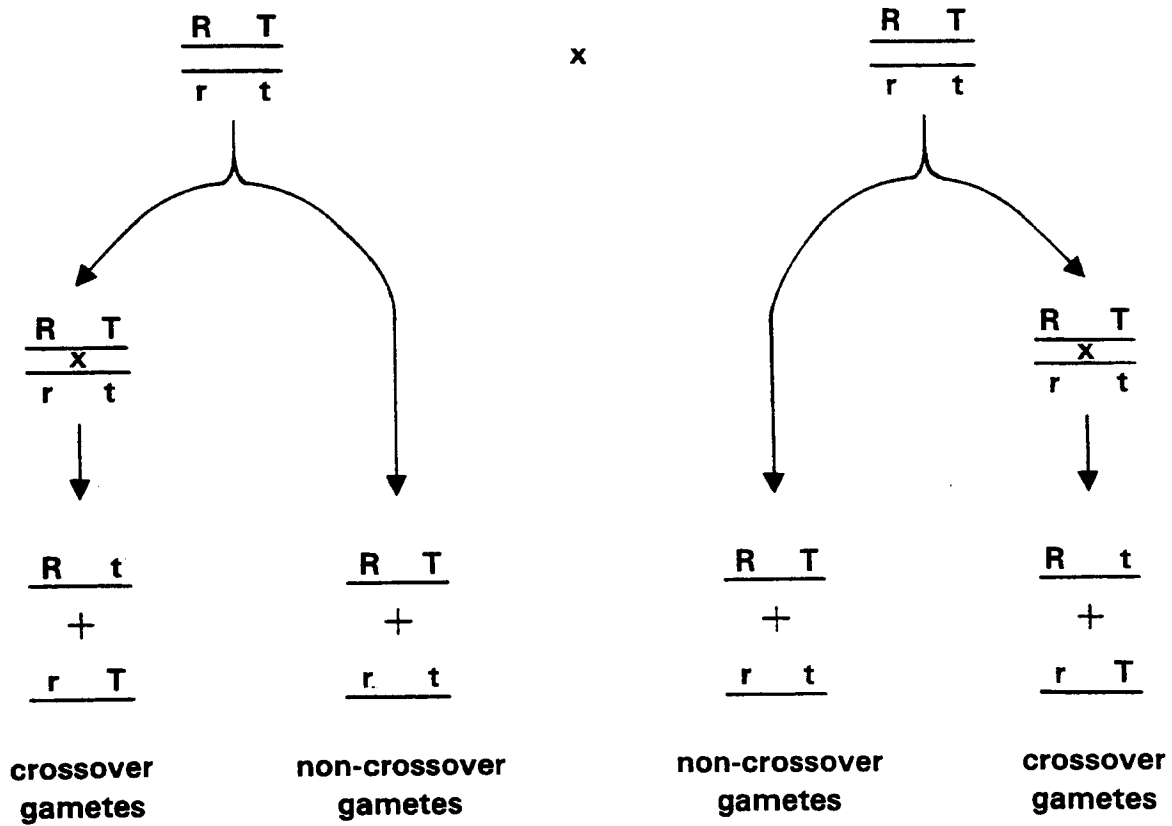


Figure 1.35 Illustration of Crossing Over

Key to Abbreviations in Figure 1.36

ABO	ABO blood group (chr. 9)	Gal ⁺ -Act	Galactose + activator (chr. 2)	MRBC	B-cell receptor for monkey red cells (chr. 6)
ACO	Aconitase, mitochondrial (chr. 3)	α GAL	α -Galactosidase (Fabry disease) (X chr.)	NP	Nucleoside phosphorylase (chr. 14)
ACO-S	Aconitase, soluble (chr. 9)	β GAL	β -Galactosidase (chr. 22)	NPa	Nail-patella syndrome (chr. 9)
ACP-1	Acid phosphatase-1 (chr. 2)	GALT	Galactose-1-phosphate uridylyltransferase (chr. 3)	OPCA-1	Olivopontocerebellar atrophy 1 (chr. 6)
ACP-2	Acid phosphatase-2 (chr. 11)	GAPD	Glyceraldehyde-3-phosphate dehydrogenase (chr. 12)	P	P blood group (chr. 6)
ADA	Adenosine deaminase (chr. 20)	GAPS	Phosphoribosyl glycineamide synthetase (chr. 21)	PepA	Peptidase A (chr. 18)
adeB	FGAR amidotransferase (chr. 4 or 5)	Gc	Group-specific component (chr. 4)	PepB	Peptidase B (chr. 12)
ADK	Adenosine kinase (chr. 10)	GK	Galactokinase (chr. 17)	PepC	Peptidase C (chr. 1)
AdV12-CMS-Ip	Adenovirus-12 chromosome modification site-Ip (chr. 1)	GLO-1	Glyoxylase I (chr. 6)	PepD	Peptidase D (chr. 19)
AdV12-CMS-Iq	Adenovirus-12 chromosome modification site-Iq (chr. 1)	GOT-1	Glutamate oxaloacetic transaminase-1 (chr. 10)	Pg	Pepsinogen (chr. 6)
AdV12-CMS-17	Adenovirus-12 chromosome modification site-17 (chr. 17)	G6PD	Glucose-6-phosphate dehydrogenase (X chr.)	PGK	Phosphoglycerate kinase (X chr.)
AHH	Aryl hydrocarbon hydroxylase (chr. 2)	GSR	Glutathione reductase (chr. 8)	PGM-1	Phosphoglucomutase-1 (chr. 1)
AK-1	Adenylate kinase-1 (chr. 9)	GSS	Glutamate- γ -semialdehyde synthetase (chr. 10)	PGM-2	Phosphoglucomutase-2 (chr. 4)
AK-2	Adenylate kinase-2 (chr. 1)	GUK-1 & 2	Guanylate kinase-1 & 2 (S & M) (chr. 1)	PGM-3	Phosphoglucomutase-3 (chr. 6)
AK-3	Adenylate kinase-3 (chr. 9)	GUS	Beta-glucuronidase (chr. 7)	6PGD	6-Phosphogluconate dehydrogenase (chr. 1)
AL	Lethal antigen: 3 loci (a1, a2, a3) (chr. 11)	HADH	Hydroxyacyl-CoA dehydrogenase (chr. 7)	PHI	Phosphohexose isomerase (chr. 19)
Amy-1	Amylase, salivary (chr. 1)	HaF	Hageman factor (chr. 7)	PK3	Pyruvate kinase-3 (chr. 15)
Amy-2	Amylase, pancreatic (chr. 1)	HEM _A	Classic hemophilia (X chr.)	PP	Inorganic pyrophosphatase (chr. 10)
ASS	Argininosuccinate synthetase (chr. 9)	Hex A	Hexosaminidase A (chr. 15)	PVS	Polio sensitivity (chr. 19)
APRT	Adenine phosphoribosyltransferase (chr. 16)	Hex B	Hexosaminidase B (chr. 5)	Rg	Rodgers blood group (chr. 6)
AVP	Antiviral protein (chr. 21)	HGPRT	Hypoxanthine-guanine phosphoribosyltransferase (X chr.)	Rh	Rhesus blood group (chr. 1)
Bf	Properdin factor B (chr. 6)	HK-1	Hexokinase-1 (chr. 10)	rRNA	Ribosomal RNA (chr. 13, 14, 15, 21, 22)
β 2M	β 2-Microglobulin (chr. 15)	HLA	Major histocompatibility complex (chr. 6)	rC3b	Receptor for C3b (chr. 6)
C2	Complement component-2 (chr. 6)	Hpa	Haptoglobin, alpha (chr. 16)	rC3d	Receptor for C3d (chr. 6)
C4	Complement component-4 (chr. 6)	HVS	Herpes virus sensitivity (chr. 3)	RN5S	5S RNA gene(s) (chr. 1)
C8	Complement component-8 (chr. 6)	H-Y	Y histocompatibility antigen (Y chr.)	SA7	Species antigen 7 (chr. 7)
Cae	Cataract, zonular pulverulent (chr. 1)	If-1	Interferon-1 (chr. 2)	SAX	X-linked species (or surface) antigen (X chr.)
CB	Color blindness (deutan and protan) (X chr.)	If-2	Interferon-2 (chr. 5)	Sc	Scianna blood group (chr. 1)
Ch	Chido blood group (chr. 6)	IDH-1	Isocitrate dehydrogenase-1 (chr. 2)	SHMT	Serine hydroxymethyltransferase (chr. 12)
CS	Citrate synthase, mitochondrial (chr. 12)	IDH _m	Isocitrate dehydrogenase, mitochondrial (chr. 15)	SOD-1	Superoxide dismutase-1 (chr. 21)
DCE	Desmosterol-to-cholesterol enzyme (chr. 20)	ITP	Inosine triphosphatase (chr. 20)	SOD-2	Superoxide dismutase-2 (chr. 6)
DTS	Diphtheria toxin sensitivity (chr. 5)	LCAT	Lecithin-cholesterol acyltransferase (chr. 16)	SV40-T	SV40-T antigen (chr. 7)
EI-1	Eliptocytosis-1 (chr. 1)	LDH-A	Lactate dehydrogenase A (chr. 11)	TDF	Testis determining factor (Y chr.)
E11S	Echo 11 sensitivity (chr. 19)	LDH-B	Lactate dehydrogenase B (chr. 12)	TK _m	Thymidine kinase, mitochondrial (chr. 16)
ENO-1	Enolase-1 (chr. 1)	α MAN	Lysosomal α -D-mannosidase	TK _s	Thymidine kinase, soluble (chr. 17)
ENO-2	Enolase-2 (chr. 12)	MDH-1	Malate dehydrogenase-1 (chr. 2)	TPI	Triosephosphate isomerase (chr. 12)
Es-Act	Esterase activator (chr. 4 or 5)	MDH-2	Malate dehydrogenase, mitochondrial (chr. 7)	TRPRS	Tryptophanyl-tRNA synthetase (chr. 14)
EsA4	Esterase-A4 (chr. 11)	ME-1	Malic enzyme-1 (chr. 6)	tsAF8	Temperature-sensitive (AF8) complementing (chr. 3)
ESD	Esterase D (chr. 13)	MHC	Major histocompatibility complex (chr. 6)	UGPP	Uridyl diphosphate glucose pyrophosphorylase (chr. 1)
FH-1 & 2	Fumarate hydratase-1 and 2 (S and M) (chr. 1)	MPI	Mannosephosphate isomerase (chr. 15)	UMPK	Uridine monophosphate kinase (chr. 1)
α FUC	Alpha-L-fucosidase (chr. 1)				
Fy	Duffy blood group (chr. 1)				

soon found in humans as well (Barr & Bertram, 1949; Barr, 1957 and 1960). Barr bodies are quite easily determined in buccal or vaginal epithelial cell smears. A significant number of cells must be scored, since the structure is not present in every cell. In examining the correlation between the number of Barr bodies in cells and the sex chromosome composition of persons with various peculiar sex chromosome abnormalities, it was noted that there is always one less Barr body than the number of X chromosomes in the cell. Thus, XY (normal males), XO (Turner females), XYY and XYYY males have no Barr body, XX (normal females), XXY (Klinefelter males) and XXYY people have one, persons with three X have two Barr bodies and so forth. According to the Lyon hypothesis, the Barr body represents the inactivated X chromosome. The Lyon hypothesis is not universally accepted, other explanations for the observations being possible. One of the puzzling aspects of the notion is imagining a mechanism for the inactivation of an entire chromosome, an event which has virtually no precedent in other organisms. X-chromosome inactivation applies only to the somatic cells. Germ cells do not have Barr bodies.

1.2.5 Mutation

It has been known for some time that the genetic material can undergo spontaneous changes in structure or composition without losing its ability of self-replication. Such changes are often reflected in changes in gene action. Structural changes in the genetic material are called *mutations*. Mutations can be understood in terms of present day biochemical genetics (section 1.2.2). Mutations represent changes in the DNA base sequence which lead to changes in the amino acid sequences of the proteins being coded for. The degree to which the protein is affected depends on which amino acid is affected and its position in the protein. Some amino acids in the protein play key roles in the maintenance of the active conformation, some are involved in the active site, and some can be changed without affecting the catalytic activity very much at all. A single base change in DNA can account for the difference between normal and sickle-cell hemoglobin, a matter which will be discussed in more detail in Unit VII. Hb-S differs from Hb-A in a single amino acid residue, the former having Val where the latter, normal Hb, contains Glu in the beta chain. The codons for Glu are GAA and GAG, but GUA and GUG code for valine. On the other hand, a single base change in DNA could result in no change at all in the protein, and would never be detected. CUA, for example, codes for leucine, but so does CUU. Only in those cases where the amino acid sequence of proteins is known, and some information is available about the three-dimensional structure, can mutations be so clearly understood. It is widely agreed though that the biochemical explanations of mutation based on the well studied cases are universal. There are other ways in which the genetic material can undergo changes, such as chromosomal aberrations. The term mutation tends to be restricted to changes in a single gene.

The mechanism of mutation is not precisely known. Even in those cases where nucleotide base changes can account for the observed results, the exact way in which the changes come about is not clear. Spontaneous mutation rates can be measured. In suitable organisms which have relatively short life cycles, and produce fairly large numbers of offspring, the rates can be measured quite accurately. In humans, the rates are far more difficult to determine, but estimates are possible for some loci. Mutation is a rare event. Different loci have different rates of mutation, and not every allele at the same locus necessarily undergoes mutation at the same rate. Ordinarily, mutation rate for a "normal" to an "abnormal" allele is considered to be the forward direction. The reverse can occur as well, and is called "back mutation". The back mutation rate is generally less than the forward rate.

Mutation can be induced by external factors. Much of what is known about genetics has resulted from the ability to induce mutations artificially in organisms suitable for genetic study. Muller made the discovery that X-radiation can induce mutations in *Drosophila* in 1927, and received the Nobel Prize for this work. Mutation can also be induced by other types of radiation, by a variety of chemicals, and in some organisms by temperature shocks.

1.2.6 Polymorphism

Genetic polymorphism is a type of variation in which members of a population with two or more different characteristics controlled at a particular locus coexist normally, and in such proportions that the rarest of them cannot be accounted for on the basis of recurrent mutation. The concept was first devised by E. B. Ford in 1940, and its implications have been explored in great detail (see Ford, 1965). Loci having alleles which are consistently deleterious to an organism are not considered polymorphic, because the characteristics are being selected against. In some cases, such as that of sickle-cell hemoglobin and several of the other structural variants of hemoglobin, the condition itself, especially in the homozygote, is quite deleterious. But heterozygotes show a considerable advantage in coping with malaria. Many loci exhibiting polymorphism control characteristics whose selective advantage to the organism is not at all clear. Much thought has been given to the mechanisms by which polymorphism is maintained in populations. Several major factors are probably involved. One is selective forces, whether they are recognized and understood or not. Another is recurrent mutation. A third is so-called "genetic drift". Genetic drift refers to changes in the proportions of genes in a population due to chance deviations from the most probable outcome in going from one generation to the next. Said another way, the most probable outcomes in the distribution of alleles into gametes, fertilization and subsequent survival, are not always the real outcomes. There is some tendency on the part of geneticists to regard selective forces as the major factor in maintaining polymorphism, but it is rarely possible to establish with certainty that such is the case, and to understand the forces at work. A great deal of attention has been paid to blood groups in this regard, as well to the

isoenzyme and serum protein polymorphisms. The selective forces in most cases are not that clear.

Genetic polymorphism provides the basis for using genetically determined characteristics as markers in populations. The frequencies of the various markers are known to vary within human populations, a fact which has been of interest to geneticists as well as to physical anthropologists. The determination of a number of markers in an individual along with a knowledge of the frequencies of the markers in a population allows for determination of the expected frequency with which such a person is expected to occur. Medico-legal applications are based in part on this aspect of polymorphic markers. In theory, if enough marker systems could be used, it would be possible to individualize a blood sample, but in practice such a potential is some ways away. Discrimination in populations improves, however, as more and more systems are added to the list of those which are practical and useful in medico-legal inquiries.

1.2.7 Methods in human genetics

Some of the methods used in human genetics will be mentioned briefly. Many good references are available if further information is wanted (e.g. Levitan and Montagu, 1971; Stern, 1973; Emery, 1976; Cavalli-Sforza and Bodmer, 1971; Dahlberg, 1948).

One of the major ways of getting information is through the study of families, and the classical method is pedigree analysis. Pedigrees are simple, diagrammatic representations of the occurrence of a characteristic in a family, often covering several generations. There is not universal agreement on pedigree symbols, but it is common to find circles representing females and squares representing males. Generations are usually designated by Roman numerals, individuals being specified by arabic numbers from left to right throughout the pedigree. Individuals can then be referred to by giving the Roman numeral and the arabic number. Fig. 1.37 shows a hypothetical pedigree for a simple Mendelian recessive trait, and Fig. 1.38 shows a hypothetical pedigree for an X-linked recessive trait. Affected individuals are indicated by blackening the sex symbols. Persons of unknown sex are represented by diamonds. Illegitimate unions are denoted by dotted lines, and consanguineous unions of whatever degree are usually denoted by double connecting lines. Pedigrees should contain an arrow indicating the index case, the first person examined, and the one responsible for initiation of the study. The person is also called the proband, or propositus (fem. proposita). Persons who are dead may be indicated by a cross (†) within or near the sex symbol. Aborted, or stillborn infants are indicated by smaller symbols or by a diagonal line through the symbol.

Studies of twins are used to get information as well. Monozygotic twins develop from the same fertilized egg and are expected to be concordant on all traits. Genetic markers can be used to establish monozygosity or dizygosity in many cases. A number of characteristics are examined, and the probability of the particular combination of traits can be calculated under the assumptions of monozygosity and of

dizygosity. The probabilities of the twins being MZ or DZ can then be calculated (see, for example, Wilson, 1970; Selvin, 1970).

1.2.8 Population genetics

Population genetics is based on considerations of all the genes in a population for a characteristic, rather than the genes of any individual or particular mating. Familiarity with statistics and probability is necessary for an understanding of the methods used in population genetics. Only a few aspects of the area will be considered in this section. Further information may be found in Cavalli-Sforza and Bodmer (1971), Dahlberg (1948), Burdette (1962), Emery (1976), Mather (1973), Jacquard (1974), and Crow and Kimura (1970).

1.2.8.1 Hardy Weinberg equilibrium. One of the basic principles of population genetics was derived by Hardy in England and Weinberg in Germany in 1908. Known as the *Hardy-Weinberg Law*, this principle states that subject to certain conditions each genotype in a population will exist in a proportion which remains constant from generation to generation. A population with this characteristic is said to be in "Hardy-Weinberg equilibrium". The following conditions are sufficient for a population to be in Hardy-Weinberg equilibrium.

- The population is randomly mating. This means that the probability of a mating between two particular genotypes is simply the product of the proportions of those genotypes in the population (i.e., matings are independent of genotype).
- There is no natural selection.
- There is no effect from mutation or migration.
- The population is very "large" (essentially infinite).
- There is no sex difference in proportions of alleles.

The following example illustrates the principle: Suppose a population satisfies conditions a, b, c, d and e, above with respect to a certain trait controlled by a simple Mendelian pair of alleles A and a. Let our population start with 50% AA and 50% aa individuals. Then, under the random mating, offspring will come from the four types of matings, $AA\sigma \times AA\varnothing$, $aa\sigma \times AA\varnothing$, $AA\sigma \times aa\varnothing$, and $aa\sigma \times aa\varnothing$, with equal frequencies of $0.5 \times 0.5 = 0.25$ (25%) each. It is easily seen (Fig. 1.39) that these matings yield AA, Aa and aa individuals in the proportion 1:2:1, i.e. 25% AA, 50% Aa and 25% aa. If we go through the same exercise with the population of offspring (see Figure 1.40), we find that the following generation is still made up of AA, Aa and aa individuals in the proportion 1:2:1. Every succeeding generation will have this same ratio of genotypes.

The *gene frequency* of an allele is the proportion of all genes at the locus where the allele occurs represented by that allele. In the example of above, where the steady state population consisted of $\frac{1}{4}aa:\frac{1}{2}Aa:\frac{1}{4}AA$, $\frac{1}{2}$ of all genes are A and $\frac{1}{2}$ are a. The gene frequency of A is 0.5. In this case the gene frequency of a is identical to that of A. In general, in a system consisting of two alleles, A and a, we might designate the gene frequencies as p and q, respectively, where $p + q = 1$.

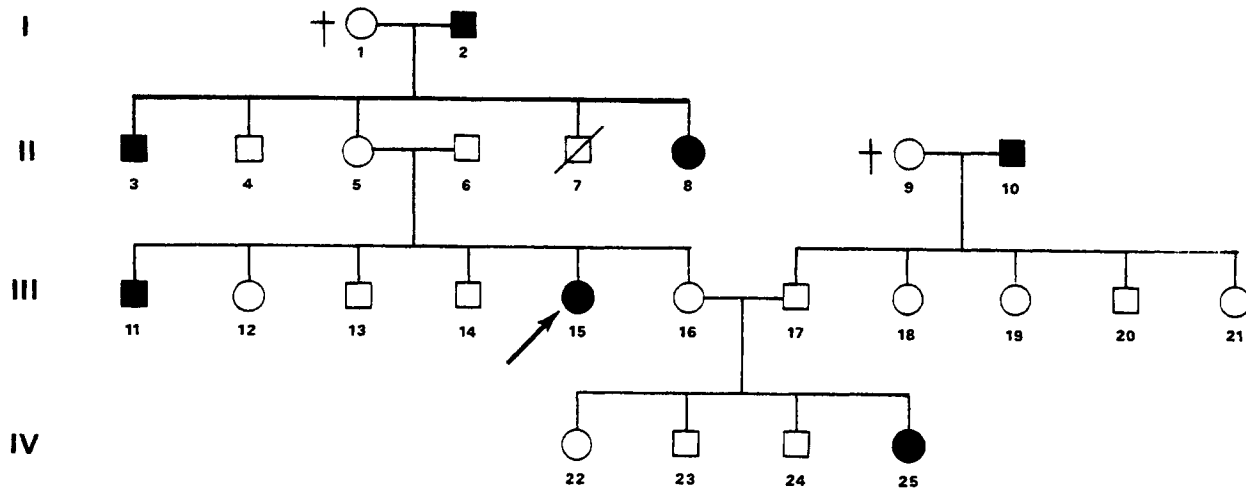


Figure 1.37 Hypothetical Pedigree for a Simple Mendelian Recessive Trait

Then the population is in approximate Hardy-Weinberg equilibrium (at least with respect to random mating) we expect the following proportions: p^2 AA individuals, $2pq$ Aa individuals and q^2 aa individuals. However, a population exhibiting these proportions exactly (even if p and q could be determined) would be extremely rare. Furthermore, we can examine only a small sample from such a population, and because of statistical sampling error, the observed sample may not be representative of the population. Therefore, statistical techniques are needed to see if the population is behaving according to Hardy-Weinberg equilibrium with variations due to random sampling errors. The main technique used is the Chi-square goodness of fit test.

When performing a Chi-square (χ^2) test we partition the population into several (k) different cells. For each cell we count the observed number of individuals in that cell and the number which would be expected if the population was in Hardy-Weinberg equilibrium and denote these numbers by O and E, respectively. The chi-square statistic is defined by the sum

$$\chi^2 = \sum \frac{(O - E)^2}{E}$$

over all cells in the partition. If χ^2 is "large", we take this as evidence that the population is not in Hardy-Weinberg equilibrium; if it is "small", that the population is probably in Hardy-Weinberg equilibrium. To decide what is "large" we must determine the number of *degrees of freedom* of χ^2 and then consult a chi-square table appearing in most statistics or genetics texts (e.g. Fisher, 1970). The table gives us the approximate probabilities of χ^2 from a Hardy-Weinberg population exceeding the tabled values by chance alone. The following examples will illustrate the point. The number of degrees of freedom equals the number of cells minus 1 minus

the number of independent parameters which must be estimated from the sample to get the E's, assuming the Hardy-Weinberg conditions hold.

For example, suppose we have a codominant system, i.e., one in which p and q can be calculated since heterozygotes are distinguishable. Moreover, suppose that we "expect" the offspring to be in the ratio 1:2:1 ($\frac{1}{4}$ AA, $\frac{1}{2}$ Aa, $\frac{1}{4}$ aa). Note that we are assuming that $p=q=\frac{1}{2}$. In a random sample of 100 of the offspring, suppose that our sample exhibited 20 AA, 58Aa and 22 aa individuals. Then, in summary:

Cell	AA	Aa	aa
observed	20	58	22
expected	25	50	25

$$\chi^2 = \frac{(20-25)^2}{25} + \frac{(58-50)^2}{50} + \frac{(22-25)^2}{25} = 2.64$$

There are 2 degrees of freedom (d.f.), computed by subtracting one from the number of cells, i.e. 3. Nothing was estimated from the sample. Using the chi-square table we see that there is a slightly less than 30% chance of getting a sample deviating at least this much from expectation by chance alone.

Another example: Suppose we have the above problem but do not know the population p value. We expect offspring to be in the ratio $p^2:2pq:q^2$ (AA,Aa,aa). However, we must estimate p (or q) from the sample. Since our system is codominant we can use the phenotypic frequencies to determine the sample gene frequencies. We then use these sample frequencies as our estimates of p and q to determine expected values. In the sample from the above example, there are $(2 \times 20 + 58)$ or 98 A genes and there are $(200-98)$ or 102 a genes. Thus we estimate $p = 98/200 = 0.49$ and $q = 0.51$, and using these values, we expect offspring to be

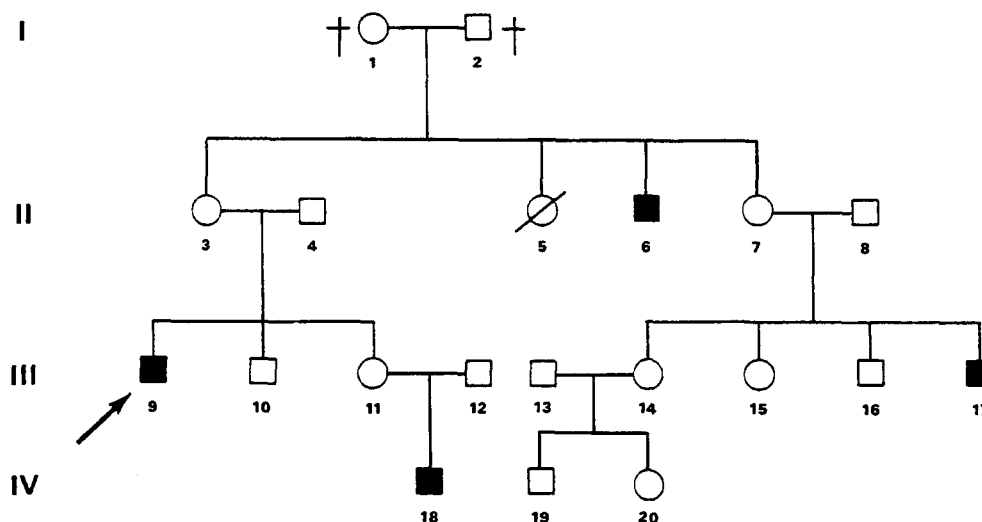


Figure 1.38 Hypothetical Pedigree for an X-linked Recessive Trait

in the proportion $(0.49)^2 AA:2(0.49)(0.51) Aa:(0.51)^2 aa$.
In summary:

Cell	AA	Aa	aa
observed	20	58	22
expected	24.01	49.98	26.01

$$\chi^2 = \frac{(20-24.01)^2}{24.01} + \frac{(58-49.98)^2}{49.98} + \frac{(22-26.01)^2}{26.01} = 2.57$$

In this case, there is one degree of freedom. We lose one degree of freedom as compared with the previous example due to the fact that one independent parameter had to be estimated from the sample (p and q are related as $p+q=1$). Using the chi-square table we see that there is just about a 10% chance of getting a sample deviating this much from expectation by chance alone.

Many workers say that deviations from expected values are significant if there is less than a 5% chance of getting deviations as large as those observed by chance alone. If the chance is less than 1%, the workers say the results are highly significant. A highly significant result indicates that the population is probably not in Hardy-Weinberg equilibrium.

The Chi-square method may be used in more complex situations, e.g., in cases of multiple alleles. In cases where one gene is dominant or where phenotype does not indicate genotype rather sophisticated statistical procedures must be used to estimate the gene frequencies. Readers interested in this subject should consult mathematical or statistical genetics texts (e.g. Kempthorne, 1969).

There are many possible reasons for deviations from Hardy-Weinberg equilibrium. If any of the sufficient conditions mentioned at the beginning of the section do not hold, then deviations may occur. Selection, heterogeneity of the

population, inbreeding and nonrandom mating patterns may all cause deviations. With regard to sampling, in addition to statistical sampling variation, we may not be taking a truly random sample of the population under consideration and we may be making errors in classifying the phenotypes. The work of Brinkman *et al.* (1971) on erythrocyte acid phosphatase types in European Caucasians illustrates, for example, how Hardy-Weinberg equilibrium analysis of data can indicate possible misdiagnosis of phenotypes. Data from a large number of people were pooled and analyzed. Deviations of observed values from those expected in CB and C phenotypes were quite significant, leading to speculation that some laboratories might be misdiagnosing CC phenotypes as CB. It must also be remembered that, since we are usually limited to small samples, our estimates of population characteristics may not be very accurate. If we wish to estimate a gene frequency for a population, then, in general, a large sample will give a more accurate estimate than will a small sample. However, data for a large sample may be too expensive to obtain or may simply be unavailable. This point should be remembered when reading papers that claim 5 place accuracy in a gene frequency estimate based upon a sample of 100 observations.

1.2.8.2 Significance of marker systems. A major objective of the use of genetic markers in blood or body fluids in medicolegal investigations is the establishment of identity or non-identity between samples which are typed and compared. In addition, however, judgments must sometimes be made as to which systems are likely to be most informative. These judgments may involve what is known about the sample's age and history in order to avoid using up samples of limited size in attempts to type markers which may no

♀	♂		
		1/2 AA	1/2 aa
1/2 AA		1/4 AA	1/4 Aa
1/2 aa		1/4 Aa	1/4 aa

Figure 1.39 Prediction of outcome of crosses in a population with 50% AA and 50% aa individuals under random mating

♀	♂				
		1/4 AA	1/2 Aa	1/4 aa	
1/4 AA		AA 1/16	1/8 Aa } 1/4	Aa 1/16	
		1/8 Aa } 1/4	1/8 Aa } 1/2	1/16 aa } 1/4	
1/2 Aa		1/16 AA	1/8 Aa } 1/4	1/16 aa	
		1/8 Aa } 1/4	1/8 Aa } 1/2	1/16 aa } 1/4	
1/4 aa		Aa 1/16	1/8 Aa } 1/4	aa 1/16	
		1/8 Aa } 1/4	1/8 Aa } 1/2	1/16 aa } 1/4	

→	$1/16 + 1/16 + 1/16 + 1/16 \text{ AA} = 1/4 \text{ AA}$ $1/16 + 1/16 + 1/16 + 1/8 + 1/16 + 1/16 + 1/16 \text{ Aa} = 1/2 \text{ Aa}$ $1/16 + 1/16 + 1/16 + 1/16 \text{ aa} = 1/4 \text{ aa}$
---	---

Figure 1.40 Prediction of outcome of crosses in a population with 25% AA : 50%Aa : 25%aa individuals under random mating.

longer be detectable. Such decisions are based on knowledge of the rate at which the various markers become undetectable as a function of time under various conditions.

Another issue, though, is the ability of a system to discriminate among members of a population. It is intuitively clear that the more phenotypes a system exhibits, and the more evenly distributed they are in the population, the greater the chance that two randomly chosen individuals from that population are different (i.e., exhibit different phenotype). Jones (1972) treated this problem quantitatively. In summary, the results given are that for each system, if we have a large enough population and if at least one phenotypic frequency is large compared to population size, then the probability of failing to distinguish between two randomly chosen individuals from that population (probability of identity) is approximated by the sum of the squares of the different phenotypic frequencies. For example, Race and Sanger give the following frequency of occurrence of ABO blood types from a large sample in Great Britain:

Phenotype	A	B	AB	O
Observed Frequency	0.417	0.086	0.030	0.467

The probability of nondiscrimination is given approximately by: $(0.417)^2 + (0.086)^2 + (0.030)^2 + (0.467)^2 = 0.400$. The probability of being able to distinguish between two individuals randomly chosen from the population, i.e., the probability of discrimination, is given by $(1 - \text{probability of identity})$, that is, $(1.0 - 0.4)$ or 0.6 in the above example. This probability is sometimes called the *discrimination index*.

If there are several independent tests on a population for discrimination purposes, then the probability of identity on all of the tests is equal to the product of the probabilities of identity on the individual tests. If, for example, in addition to the 0.4 probability of identity in ABO typing above, we estimated a 0.38 probability of identity in the MN blood group system, then under independence, the probability of identity when using both groupings would be $(0.4)(0.38) = 0.152$. The discrimination index, therefore, becomes 0.848. Frequently, instead of considering the probability of identity (say P), workers consider the logarithm of the reciprocal of P, $-\log(P)$. This value is large when P is small, and small when P is large (Fisher 1951). It has the advantage of being

additive with respect to different independent tests when being used as a discrimination index. This additivity property makes it easier to compare the relative values of different systems when used together for discrimination. For examples of the use of this measure of discrimination, see Fisher (1951).

1.3 Immunology and Serology

1.3.1 Introduction

Since the earliest investigations into the basis of resistance to infectious diseases, and into ways of producing immunity by artificial means, immunology has become a complex and rapidly developing discipline unto itself. It encompasses the subjects of immunity, serology, immunochemistry and immunobiology. As with any rationally developed intellectual discipline, a number of unifying concepts have emerged over the course of time. From the point of view of forensic science, immunological methods and techniques are primary tools for identification and individualization of biological materials. Many aspects of immunology are discussed in subsequent units in the context of their medico-legal applications. Section 1.3 consists of a general discussion of some of the principles of immunology, with emphasis on those that have a bearing on medico-legal tests and methods. Many important topics have been omitted from the discussion because they do not have much direct relationship to forensic immunology. Readers interested in immunology will find considerable information in the books and reviews cited in the reference list.

1.3.2 Antigens

1.3.2.1 The nature of antigens. Antigens are ordinarily defined in terms of their actions and effects. There is no entirely satisfactory definition of an antigen. They have been defined in terms of the antibodies which they elicit; if, however, antibodies are then defined in terms of the antigens which elicited them, a kind of meaningless circularity is introduced. An antigen is a substance which (1) will cause the production of specific antibodies when introduced into an animal and/or (2) reacts in some visible way with antibodies. More generally, it can be said that an antigen is any substance which can induce a specific immunological response in an animal, or which can be involved in a specific immunological reaction, either *in vivo* or *in vitro*. The term *immunogen* has been used to denote a substance which can bring about a specific immunological response *de novo*, as against those substances which can react with preformed antibodies, or evoke specific immunological responses in previously immunized animals, but which cannot elicit *de novo* immunological responses. The latter are often referred to as *haptens*, a term introduced by Landsteiner. Some authors have used the term *haptens* to refer to the specific chemical groupings on antigens with which the antibody interacts, but these groupings are now more often called *determinant groups*.

1.3.2.2 Conditions of antigenicity. A complete under-

standing of all the properties that render a particular material antigenic in a particular animal has not yet been attained, but some of the criteria are known: (1) Antigens must contain chemical groupings which are foreign to the immunologically competent cells of the test animal; (2) Antigens must have access to the antibody-forming machinery of the test animal; (3) Antigens must possess a certain minimal degree of molecular complexity and size. There are probably other criteria as well, which are not well understood. Proteins and higher MW carbohydrates are immunogenic, but lipids and nucleic acids ordinarily are not, unless they are combined with a protein.

It is an accepted principle of immunology that animals do not ordinarily make antibodies against constituents of their own bodies. This notion was first enunciated by Ehrlich and Morgenroth in 1901:

In the third communication on isolytins, we pointed out that the organism possesses certain contrivances by means of which the immunity reaction, so easily produced by all kinds of cells, is prevented from acting against the organism's own elements, and so giving rise to autotoxins. Further investigations made by us have confirmed this view, so that one might be justified in speaking of a *horror autotoxicus* of the organism.

The "foreignness" of the material does not have to reside in its consisting of an entirely different chemical substance, but can be a function of configuration or of conformation. Generally speaking, the more "foreign" a material is to the animal (i.e. the more taxonomically remote the source of the antigen), the more antigenic it is likely to be. There are apparent exceptions to this generalization, in that constituent molecules of organisms, especially proteins, have evolved at different rates. Thus, certain molecules may be very similar in structure and conformation, even though they come from taxonomically remote animals. Such similarities tend to be found in molecules which are involved in biochemical activities common to most animals, and which are at the same time vital to the maintenance of life. It is as though evolution, proceeding blindly by trial and error, has conserved those structures which were well adapted and which were vital to survival. Organisms which possessed deviant molecules, not as well suited to their function, were selected against, and probably perished. Horse hemoglobin, for example, is poorly antigenic in the rabbit, and insulin, even from remote animals, is not normally antigenic in humans. Immunological reactions can, in fact, be used to assess taxonomic relationships between the source animal and the test animal, a subject which is discussed in more detail in sections 16.8 and 16.9.

Antibodies are not elaborated to an antigen unless the antibody-forming system "sees" them. Antigens must therefore be soluble or solubilizable. Some synthetic polymers are not very antigenic, and the fact that they are neither very soluble, nor very effectively degraded, may account for this observation. The form in which the antigen is presented, and its route of administration are also important factors. It is

usually said that antigens are substances which elicit an immunological response when administered parenterally. Strictly speaking, it does not matter how the antigen is administered, but the fact is that in most instances, the digestive system destroys or greatly alters substances which are ingested. Hypersensitivity to food allergens, however, is clearly the result of antigenic materials which have been ingested. Hypersensitivity is discussed in section 1.3.6. The use of adjuvants is related to the necessity for exposure of the animal's antibody-forming system to antigen. Adjuvants prolong the period during which the antigenic stimulus is operative, and they may also have a role in causing the antigen to come into contact with the right kind of cells.

Low molecular weight compounds are not antigenic. Very few substances with molecular weights of less than 5000 are antigenic. Generally, the higher the MW of an antigen, the more antigenic it is. The reason for this correlation probably resides in the fact that all high MW biological molecules are polymers of smaller molecular weight compounds, whose composition and three-dimensional structure can vary in an enormously large number of different ways. It is likely that larger, and correspondingly more complex molecules, therefore, present the animal with a much larger array of antigenic determinants. Size alone, however, does not determine antigenicity. The composition, and corresponding molecular complexity is important as well. Carbohydrates are generally less antigenic, for example, than proteins of about the same MW and size. Low MW polysaccharides are not particularly antigenic. Dextrans, ranging in MW from 50,000 to 100,000 are antigenic in some species, but not very much so in others. Poorly antigenic molecules may sometimes be rendered more antigenic by absorbing them on particulate materials, such as colloidon or kaolin. Large synthetic polymers, such as polystyrene and nylon, are not antigenic presumably because they are made up of only a few monomeric components, which do not offer the opportunity for very much internal molecular complexity in the finished molecule.

Another criterion for antigenicity may be maintenance of rigidity of structure within the antigenic determinant groups. Thus, there is some relationship between the antigenicity of a protein and its aromatic amino acid content. Aromatic diazo compounds make far better haptens than do long chain fatty acids, presumably because of the rigidity of the aromatic ring and the non-rigidity of paraffin chains.

1.3.2.3 Types of antigens. The terms *autologous*, *heterologous*, *homologous*, or *heterophile* are sometimes used in describing antigens. An autologous antigen is one from the same organism, which under appropriate circumstances, would induce antibody formation. Heterologous antigen is a different one from that which was used for the immunization. It may cross react with the antiserum or it may not. Homologous antigens refer to those which were used to prepare the antiserum. So-called "heterophile antigens" are those which exist in very different animals and plants, but which are so closely related structurally that antibodies to

one cross-react with the others. In many instances, heterophile antigens are polysaccharides. Human blood group A antigen, for example, is cross reactive with antibodies to pneumococcus capsular polysaccharide type XIV, and human blood group B antigen reacts with antibodies to certain strains of *E. coli*. Perhaps the best known example of a heterophile antigen is the Forssman antigen. As originally described, Forssman antigen is one present in most guinea pig tissues which would elicit the production of sheep red blood cell lysins in rabbits. The "antigen" is, in fact, a hapten and not a complete antigen, but it is widely distributed in animals and in plants. The nature of the Forssman hapten from sheep erythrocytes was investigated by Diehl and Mallette (1964) among many others.

1.3.2.4 Antigen specificity and the nature of the antigenic determinant. The evidence concerning the relationship between antigenic structure and antigenic specificity indicates that specificity resides in structure. It is fairly clear as well that only a part or parts of the antigen molecule actually induce formation of the antibody. The parts which do so are called antigenic determinants, and they comprise the structural constellation which also reacts with the antibody. When antibodies are obtained to simple chemical compounds, or haptens, by coupling them in some way to larger molecules, the hapten is then a kind of "artificial antigenic determinant". Approaches to the study of the nature of antigenic determinants have consisted of studies on degraded antigens, synthesis of antigens, and alterations of antigens. This subject was discussed by Sela (1971). It has been known for quite some time that antibodies are capable of distinguishing between very subtle differences in antigenic structure. If, for example, L-, D- and meso-tartaric acids are conjugated to proteins by a diazo reaction with the corresponding aminotartronic acids, and employed as antigens, Landsteiner showed that antibodies prepared with a different carrier protein conjugated with the various isomers of tartaric acid would readily distinguish these stereoisomeric determinants. Degradation studies on "artificial" antigens have indicated that a relatively small fragment of the protein, polypeptides of about 8-12 residues, could inhibit the reaction of antibody with undegraded antigen. The presence of aromatic amino acids in the fragment can also have a disproportionately large effect on the ability of the fragment to inhibit the reaction. The minimum number of residues required to constitute an antigenic determinant in a polysaccharide antigen is also small.

A number of studies on specific protein antigens whose complete structure is known have yielded considerable information about the particular amino acid constellations which constitute the antigenic determinant. These include studies on TMV protein, RNase and lysozyme. Antigens may be said to have "valence". In some cases, the number of antibody molecules which combine with a molecule of antigen can be determined, and the value varies considerably from one antigen to another. It is probable that the value obtained, when the measurement can be made, is a minimal

one, because the antibody molecules are large, and may well sterically hinder one another from combining with every available site on the antigen.

1.3.3 Antibodies

1.3.3.1 Formation of antibodies—The immune response. Antibody formation is induced by administration of an antigen to an animal. The antibody molecules appear in serum, and their formation period is accompanied by the elimination of the antigen from the animal. Characteristically, intravenously injected antigen is cleared from the body in three stages. The first is very rapid (minutes), assuming that the serum concentration is being followed as a measure of clearance, and represents the equilibration between circulating antigen and that in tissues and other body fluids. Phagocytosis in liver and lung is involved in the first stage in the case of particulate antigens. Soluble antigens are removed somewhat more slowly. The second stage is slower and involves gradual catabolic degradation of the antigen. This stage lasts for several days. The persistence of antigen in this stage is, by and large, a function of the enzymatic degradation capability of the host organism. The third stage of antigen removal is again rapid. In this, the immune-assisted stage, antibodies have formed and elimination of the antigen is being enhanced by the combining of antibody with antigen. The amount of detectable antibody in serum with time follows a fairly reproducible course as well. It may be several hours to several days before detectable antibody appears, this depending upon the kind of antigen administered, the route of administration, the species of the host animal and the state of its health. Antibody usually appears within 5–10 days. The latent period reflects the time required for the concentration of antibody to build up to detectable levels within serum, and not an absence of antibody production at the cellular level, for it can be shown that antibody production by isolated antibody-forming cells begins very quickly (within minutes) of exposure to the antigenic stimulus. Antibody titer in serum then increases over the course of a few days to a few weeks, plateaus, and then decays slowly. The exact time course of antibody production varies with test animal, the antigen given, the dosage, the route of administration, and a number of other things. Synthesis of antibody in an animal in response to an antigen never before encountered by the animal is sometimes called the primary response. If a subsequent dose of antigen is administered to the same animal, a so-called secondary immunological response, which differs substantially from the primary response, is seen. Circulating antibody levels decrease briefly in the secondary response because of their combination with the newly administered antigen. Very shortly thereafter, within 2–3 days certainly, antibody titer in serum increases markedly, the increase continuing for several days. The final titer is ultimately much greater than the maximal titer obtained in the primary response. The secondary response is also sometimes called the *memory*, *anamnestic* or *booster* response. Secondary response time characteristics indicate

that the antibody-forming system of the test animal has been in some way “primed” for rapid response to previously encountered antigen. The secondary response represents a rapid synthesis of new antibody, and not a rapid release of prefabricated molecules. It can be induced at almost any time after the primary response has occurred, even after very long time intervals, although the booster response after lengthy time intervals is somewhat less dramatic than that which occurs after shorter ones. The booster response can be repeated a number of times, and cross-reacting antigens will induce it as well, its intensity being directly proportional to the degree of cross reactivity with the primary antigen. The nature of the antibodies is different in the secondary response as well, the serum titer of IgG being very much higher, whereas the primary response tends to give rise primarily to IgM antibodies. IgG and IgM and other immunoglobulin types are discussed below.

The cellular mechanism through which immune phenomena become possible in an animal, and antibodies are thus synthesized, is quite complicated, and not yet fully understood. The spleen, the lymphatic tissues, and bone marrow, as well as the thymus, are involved in immunological responses. The principal cells of the immunological system are lymphocytes, derived from stem cells of bone marrow. They migrate via circulation to various sites and take up residence there. Those which develop in the thymus become so-called T-lymphocytes, or T-cells, while those that develop in the bursa of Fabricius in birds or in its mammalian equivalent become B-lymphocytes, or B-cells. Lymphocytes are resting cells until the cell surface is perturbed by an outside agency, such as so-called mitogenic agents (e.g. concanavalin A or milkweed extract), or an extrinsic antigenic material. Lymphocyte response to the latter is specific; to the former, non-specific. Response to antigenic material varies considerably with different animals, antigens, and so forth, and the combination of factors ultimately determines what sort of immunological response will be observed. Lymphocytes active in cell-mediated immunity and delayed hypersensitivity responses are T-cells, which do not secrete antibody. Humoral immunity and antibody production are functions of activated B-cells, and it is known that T-cells play some role in this process as well.

There is considerable variation in the immunological response of different animals of the same species. Responsiveness is a function of the genetic makeup of the animal, and of its age. Some animals are not responsive to immunization regardless of the adjuvant or route of inoculation employed. Older animals are generally less immunologically responsive than younger ones.

1.3.3.2 Types and structure of antibody molecules. Antibodies are immunoglobulins. Immunoglobulin molecules consist of two light and two heavy polypeptide chains held together by disulfide bridges through the half-cystine residues in the chains. The polypeptide chain arrangement in rabbit IgG is shown in Fig. 1.41(a), and the diagrammatic structure of a human IgG in Fig. 1.41(b).

Immunoglobulins are distributed in five classes, according to differences in their structure, which, in turn, lead to differences in the character of their own antigenic determinants. Some properties of the five classes of immunoglobulins, IgG, IgA, IgM, IgD and IgE are shown in Table 1.5.

The structure of IgG was solved first, and it is the most well studied of the immunoglobulins. The decisive studies were done by G. M. Edelman in this country, and by R. R. Porter in England, for which they shared the 1972 Nobel Prize for Physiology or Medicine. Edelman found that the purified molecule was resistant to reductive cleavage by sulfhydryl reagents, such as mercaptoethanol, unless it were first treated with high concentrations of urea or guanidine. These compounds interrupt the hydrogen bonds which maintain the unique folded structures of globular proteins, and expose groups within the molecule that are inaccessible when the protein is in its native conformation. In the case of IgG, urea denaturation allowed the sulfhydryl reagent to reduce the -S-S- bonds to free -SH groups. When the molecule was examined after this treatment, it became clear that the original molecule had been split into two pieces, one heavier than the other, and comparison of the MW of the fragments with that of the native protein indicated that the molecule consisted of two heavy and two light fragments. The heavy fragments are usually called heavy chains, or H-chains, the light fragments, light chains, or L-chains. The structure of IgG may be simply represented, therefore, as H_2L_2 .

Porter's observations were based on treatment of the native molecule with proteolytic enzymes in a mildly reducing environment. Such treatment results in cleavage of the molecule into fragments of two types, but which are quite different from those obtained by reductive cleavage in urea. One of the fragments crystallizes at 4° and is termed the Fc fragment (fragment crystallizable). It does not bind antigen, and represents the carboxy-terminal ends of the two H chains. The remaining fragment, which still possesses antigen-binding activity, is known as the Fab fragment (fragment antigen binding). Based on the fact that intact IgG molecules can bind two antigen equivalents, and on consideration of the molecular weights, it became clear that the intact protein consisted of 1 Fc and 2 Fab fragments. The Fab fragment consists of an amino-terminal half of an H chain and an L chain. The molecule can be cleaved with either papain or by pepsin, the latter yielding a fragment which is almost identical to Fc (obtained with papain) which is known as Fc'. The papain cleavage point in the molecule is indicated diagrammatically in Fig. 1.42. For further details on these studies, the brief but interesting accounts by Porter (1976) and by Edelman (1976) may be consulted. Largely through the availability of relatively large amounts of particular types of molecules from patients suffering from various neoplastic diseases, it has been possible to carry out amino acid sequence studies of some immunoglobulin molecules, greatly increasing our understanding of their structure.

The IgG molecule may have either of two types of light

chains, these being designated κ or λ . The H chains of IgG are designated γ chains, to distinguish them from the H chains of the other immunoglobulins. An IgG molecule may, therefore, have the structure $\gamma_2\kappa_2$ or $\gamma_2\lambda_2$. κ and λ chain containing IgG molecules are found in the same individual, but κ and λ chains do not occur in the same molecule. It has been found that certain segments of both the L and H chains tend to vary in amino acid sequence in molecules from different sources while other segments are relatively constant in sequence regardless of source. The former type of segment is referred to as a variable region, while the latter type is known as a constant region. In κ and λ chains, the constant regions, sometimes designated C_κ and C_λ , respectively, consist essentially of the carboxy-terminal halves of the chains. The amino-terminal halves of the chains are variable and are sometimes designated V_κ or V_λ . γ -chains show similar properties in this regard, the amino-terminal segment of about 120 amino acid residues, and residing in the Fab fragment, being variable. This segment may be designated V_γ . The carboxy-terminal segment of the γ -chain, about 325 amino acid residues, may be subdivided into three subregions, each of whose sequences are found to be relatively constant in molecules from different sources. These constant regions are sometimes called $C_{\gamma 1}$, $C_{\gamma 2}$ and $C_{\gamma 3}$ (see Fig. 1.41(b)).

The remaining immunoglobulin classes are distinguishable on the basis of the nature of their H chains. The heavy chains of an IgA molecule are designated α , of an IgM molecule, μ , of an IgD molecule, δ , and of an IgE molecule, ϵ . Thus, just as the structure of IgG may be represented by $\gamma_2\kappa_2$ or $\gamma_2\lambda_2$, the structure of IgA is $\alpha_2\kappa_2$ or $\alpha_2\lambda_2$, that of IgD is $\delta_2\kappa_2$ or $\delta_2\lambda_2$ and that of IgE is $\epsilon_2\kappa_2$ or $\epsilon_2\lambda_2$. IgM is a very large molecule with a MW of 800,000-900,000. Its heavy chains are designated μ , and it has been found to consist of five subunits. Its structure is written $(\mu_2\kappa_2)_5$ or $(\mu_2\lambda_2)_5$.

Edelman (1971) reviewed antibody structure in detail. Detailed studies on the structure of IgA have been carried out by Grez *et al.* (1971) and on IgE by Kochwa *et al.* (1971). Lie *et al.* (1976) reported the complete covalent structure of a human myeloma IgA1 immunoglobulin. Kabat (1970) discussed the approaches used to elucidate the nature of antibody combining sites.

It may be noted that the nomenclature of immunoglobulins and their components can become quite cumbersome, since there are a number of different terms and symbols. The nomenclature has been standardized for the most part by international agreement, and the recommendations have been incorporated into the literature rather quickly. For detailed presentations of the recommended nomenclature, see Ceppellini and many others (1964), Kunkel and others (1966), Bennich and others (1968), Asofski and others (1969) and Subcommittee for Human Immunoglobulins of the IUIS Nomenclature Committee (1972). The recommended standardized rules for nomenclature have been followed in the above discussion. None of the older nomenclature has been used. It was formerly acceptable to designate immunoglobulins either by Ig or by γ . Although

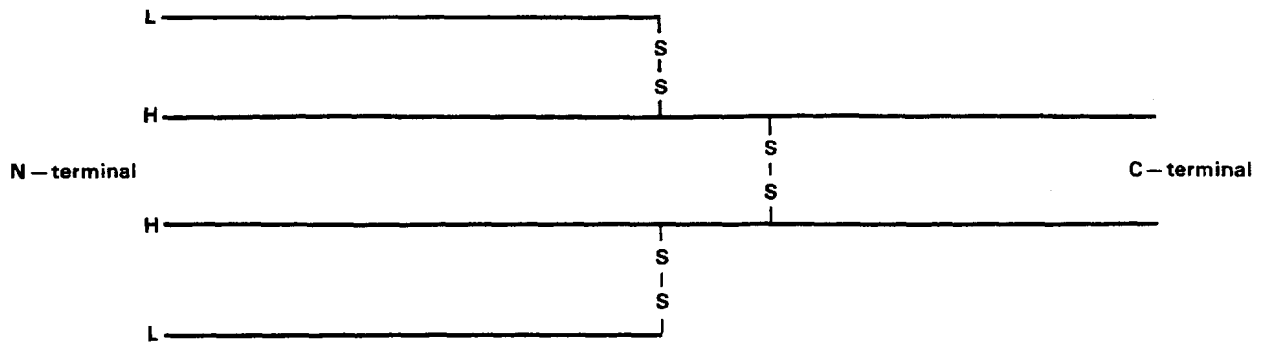


Figure 1.41 (a) Diagrammatic Structure of Arrangement of Polypeptide Chains in Rabbit Immunoglobulin Molecule

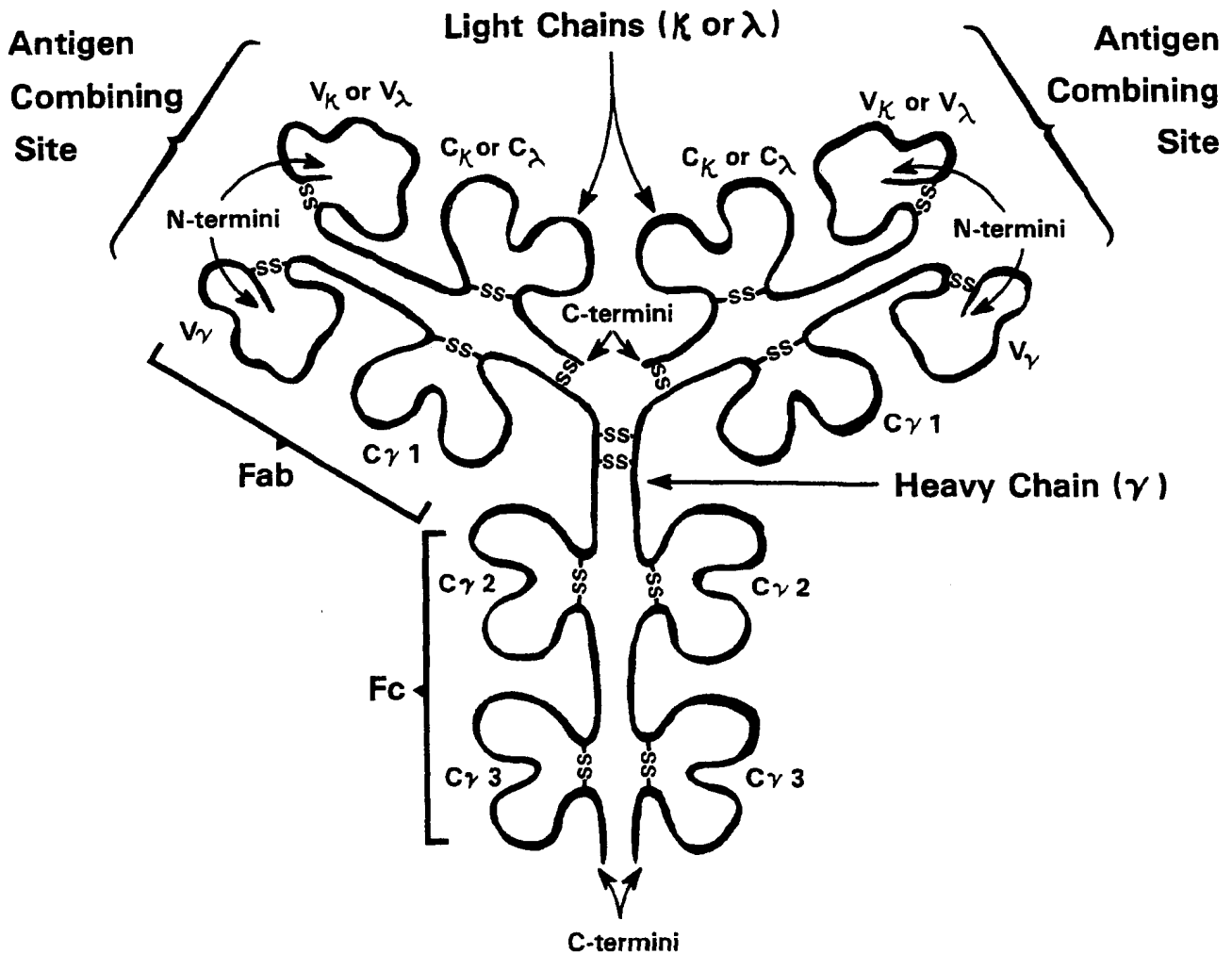


Figure 1.41(b) Diagrammatic Structure of Human IgG Molecule

Table 1.5
Comparison of some properties of the classes of immunoglobulin molecules

Characteristic	Immunoglobulin				
	<u>IgG</u>	<u>IgA</u>	<u>IgM</u>	<u>IgD</u>	<u>IgE</u>
Percent of total immunoglobulin in serum	75-85	5-10	5-10	1	1
Sedimentation coefficient	6-7S	7-11S	19S	6.1S	8.2S
Molecular weight	143,000-149,000	158,000-162,000	800,000-950,000	175,000-180,000	185,000-190,000
Carbohydrate content (o/o)	2.5	5-10	5-10	10	12
Half-life (days)	25-35	6-8	9-11	2-3	2
Stable at 56-60°	Yes	Yes	Yes	Yes	No
Immunologic valence	2	2	5-10	—	—

the nomenclature groups have recommended that the usage of γ as a synonym for Ig be discontinued, one still encounters it. Thus γ G would be identical to IgG, γ M to IgM, and so forth.

It is worthy of mention here that immunoglobulins are known to exhibit hereditary differences in structure, which can be readily detected using antibodies to specific antigenic determinants within the immunoglobulin molecule. This phenomenon has been termed *allotypy*, and the various subclasses of chains which can be distinguished on the basis of these variations are known as *allotypes*. The most important examples of allotypy from a medico-legal point of view are those occurring in the γ chain of IgG and in the κ light chains. The system of genetic variants which can be detected in the γ chain is known as the Gm system. It is quite complex, and a large number of Gm allotypes have been discovered. The κ chain allotypes constitute what is known as the Inv or Km system. These immunologically detectable variations constitute an important category of genetic markers in human beings, and will be discussed fully in Unit VII, section 44.

The blood group antibodies may belong to several different immunoglobulin classes. Early studies indicated that the isoagglutinin activity of human serum was associated with what are now called IgG and IgM (Pederson, 1945; Deutsch *et al.*, 1947). This activity may also be associated with IgA antibodies (Rawson and Abelson, 1964). Most IgG molecules can cross the placenta, and are associated with hemolytic disease of the newborn (see Fahey, 1970). IgG antibodies are usually poorly agglutinating in saline, but can be detected with anti-human globulin (or Coombs) sera, which are strongly anti-IgG (see section 1.3.4.1), by the use

of high protein media, or by the use of proteolytic enzyme treatment of red cells.

1.3.4 Antigen-antibody reactions

It has been customary to regard antigen-antibody reactions as taking place in two stages. It should not be concluded from this statement that there is no overlapping between the stages; indeed, thinking of the reaction as a two stage event is primarily a convenient way of looking at it. It is clear that certain events must take place before others, and the two stage concept helps in understanding what takes place. The first stage of the reaction is the combination of specific groups of the antibody with specific groups of the antigen or hapten. This stage is not accompanied by any visible evidence that any reaction has taken place. In the second stage, observable reactions may take place, such as agglutination, precipitation, lysis, complement fixation, and so on. Bordet was the first to propose this sort of two-stage mechanism for the reaction. The first stage proceeds quickly, and is detectable only indirectly. In the case of small haptens, the first stage may occur without a second stage following at all. The first stage does not require electrolytes, whereas the second stage does, and the second stage can be prevented from occurring by excluding electrolytes. The second stage is slow in comparison to the first. It is thought that the major change in free energy takes place in the first stage. The forces involved in antigen-antibody binding are believed to be relatively weak ones, most likely consisting of a combination of electrostatic, hydrophobic and van der Waals interactions. Antigen-antibody reactions are reversible, and can be treated thermodynamically just like other chemical reactions. The second stage of the reaction is the

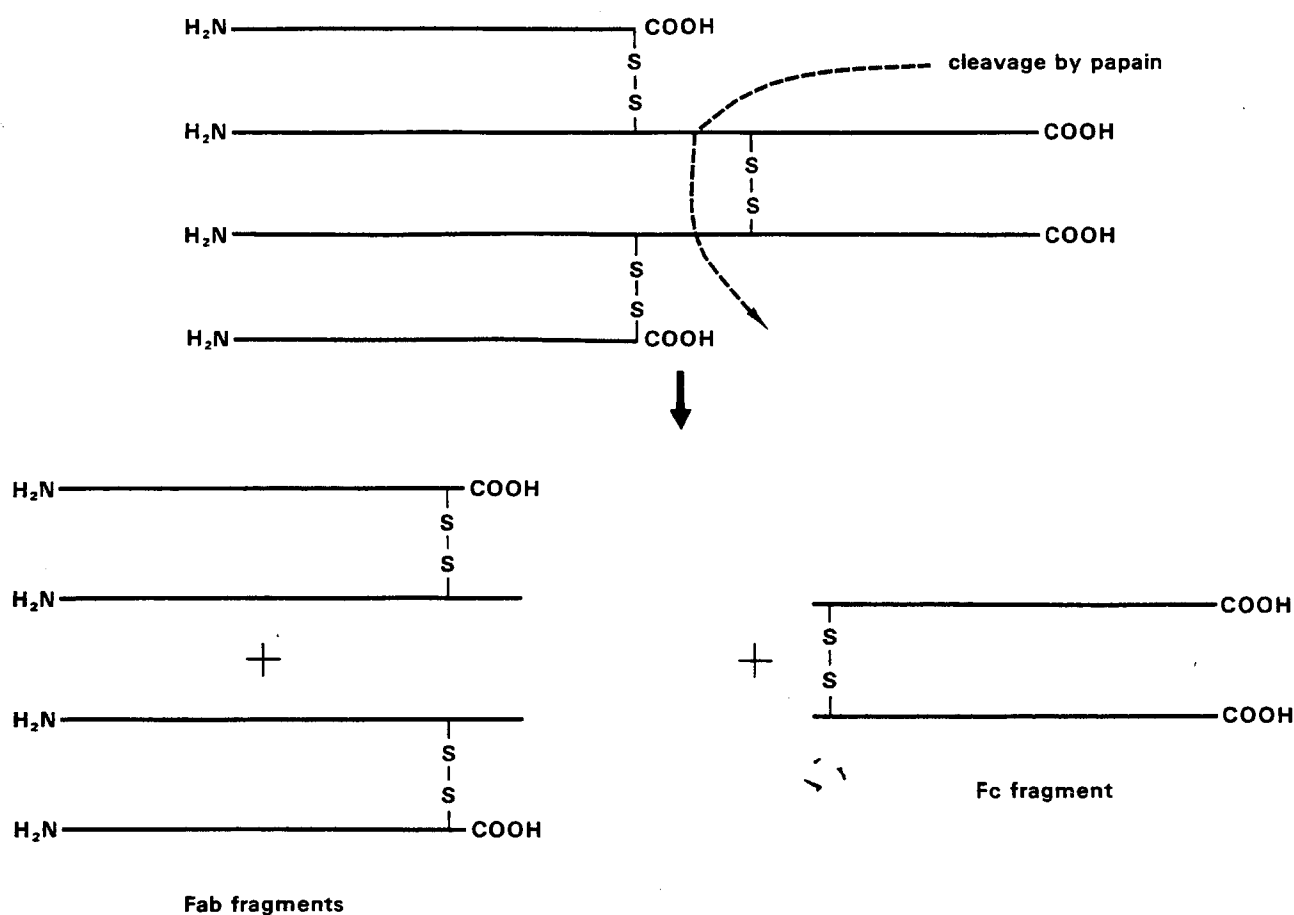


Figure 1.42 Proteolytic Enzyme Cleavage of IgG.

visible, detectable one. Particular antigen-antibody reactions are identified by the kind of second stage reaction which occurs, e.g. agglutination, precipitation, lysis, etc. Antibodies which bring about particular second stage reactions are often similarly identified, e.g. agglutinins, precipitins, hemolysins, etc. Although these descriptive names for antibodies grew out of the period in the development of immunology when it was not yet clear that the same antibody could exhibit many of these functions, the terminology has persisted, and is still useful. The second stage reaction manifestations that are of particular interest in immunological and serological tests in legal medicine are agglutination, precipitation and complement fixation and cell lysis. Reactions involving bacterial cells, or neutralization of toxins by antitoxins are not of major concern in medico-legal techniques. An interesting series of papers in the older literature by Huntoon (1921), Huntoon and Estris (1921) and Huntoon *et al.* (1921) gives a good perspective on the state of knowledge about antigen-antibody reactions and about the nature of antibodies at that time.

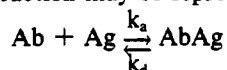
1.3.4.1 Agglutination. Agglutinin-containing sera can be prepared against both bacterial and red cell antigens. Other cells, such as yeast, or fungal cells, spermatozoa and leucocytes, can be agglutinated by specific antisera as well, and artificial insoluble particles, such as antigen-coated latex particles, can be used for agglutination tests.

Agglutination is believed to be the result of di- or multi-valent antibody molecules being combined with the antigenic determinants of two or more cells, forming a kind of network of links which holds the cells together in an array.

It is well to keep in mind the great differences in size between cells and antibody molecules. Van Oss (1973) has noted that if a red cell were imagined to be about the size of an opened book, then the largest immunoglobulin molecule, the decavalent IgM, would fit comfortably within a lower case "o"; and divalent IgG molecules would be roughly the size of a comma. It is not surprising, therefore, that on the basis of size alone IgM is a much better agglutinin than is IgG. Depending upon the spacing of the antigenic determinants, their total number, and avidity, IgG antibodies

may be incapable of effecting agglutination. Such antibodies are often referred to as "incomplete antibodies", because they do not alone bring about agglutination in saline, and because it was once erroneously supposed that they were monovalent. The IgG antibodies do bind the antigenic determinant on the cells, but may attach with both valences to the same cell. With a concentrated antiserum, containing a high proportion of such IgG molecules, the cell's antigenic receptors may become saturated with them, such that available IgM antibodies cannot bring about agglutination for want of an available binding site. Antibodies which fail to bring about agglutination in saline may be detected by the use of anti-human globulin (AHG) antisera. In this case, the AHG serves as the linking agent to bring about the agglutination of cells sensitized with incomplete antibody in a prior step. Cells which have a specific antibody bound to the antigenic determinant, but which are not agglutinated, are said to be "sensitized". In addition, antibodies which fail to bring about agglutination in saline may do so in high protein media, or if the cells have been treated with proteolytic enzymes. The "incomplete" antibodies are most frequently IgG. A number of studies have focused on the mechanism of agglutination, in an effort to arrive at a satisfactory explanation for these various phenomena.

The antigen-antibody interaction involving red cell antigens may be treated physico-chemically. The material to be discussed here may be found in Mollison (1972), and in the papers by N. C. Hughes-Jones (1974 and 1975). The antigen-antibody reaction may be represented as



where Ab represents antibody, Ag antigen, AbAg the complex, and k_a and k_d are association and dissociation constants. According to the mass action law, the velocity of the forward reaction (to the right as written) is given by

$$v_f = k_a [Ag][Ab]$$

and that of the reverse reaction by

$$v_r = k_d [AbAg]$$

where the terms in square brackets represent the concentrations of the reacting species.

At equilibrium, $v_f = v_r$, and $k_a [Ab][Ag] = k_d [AbAg]$. The equilibrium constant is

$$K = \frac{k_a}{k_d} = \frac{[AbAg]}{[Ab][Ag]}$$

Equilibrium constants may be estimated by putting various red cell concentrations with radiolabelled antibody, and determining the concentration of free antigen when half the Ab is combined with Ag. Under this circumstance,

$$\frac{[AbAg]}{[Ab]} = 1$$

and since

$$\frac{[AbAg]}{[Ab]} = K [Ag], \text{ then } K = \frac{1}{[Ag]}$$

In determining the equilibrium constant for a particular reaction, it is usually assumed that each Ab molecule combines with a single site, and that the total number of

available antigenic sites is equal to the total number of Ab molecules of a particular specificity that can combine with a red cell. The equilibrium constants for the reactions of blood group antibodies investigated have K values of the order of 10^8 l/mole, with a range from 10^4 to 10^{10} l/mole. Variation is seen not only between different examples of antisera, but between different antibody molecules in the same antiserum. The measured value is thus a weighted average for the different antibodies within an antiserum. Antibodies with higher K values are more effective in binding to antigen at lower concentrations than those with lower values, as may be appreciated by considering that

$$\frac{[AbAg]}{[Ag]} = K [Ab]$$

Pollack *et al.* (1965) studied the second stage of the agglutination reaction rather extensively from a physico-chemical point of view. Their findings support an hypothesis which emphasizes the importance of the surface potential of the cells in the agglutination reaction, and provides a framework for the explanation of the effect of adding high MW polymers to the medium, and of treating the cells with proteolytic enzymes.

Under ordinary circumstances, the cells in suspension have a net negative surface charge, and are therefore repelled by one another to an extent governed by the surface charge density. When cells are suspended in electrolyte solutions, the ions present orient themselves around the cell surface, the orientation being more orderly if they are closer to the cell. The result is a kind of diffuse electrical double layer about the cell surface, across which exists a so-called zeta-potential (ζ -potential). The stability of a cell suspension is related to the zeta potential. Pollack *et al.* (1965) derived some theoretical relationships between the ζ -potential, the electrophoretic mobility of the cell, the surface charge density, the dielectric constant of the medium, and the "thickness" of the double layer. In this way, a number of measurements could be carried out to determine the effects of changes in the medium, or treatment of the cells with proteolytic enzymes, on the ζ -potential.

As noted above, the addition of certain high MW polymeric colloids to suspensions of red cells, along with specific antisera to a cell antigen, can bring about agglutination which would not occur in their absence, or can greatly enhance agglutination in comparison to what it would have been in their absence. Among the materials that have been employed in this way are serum albumin, ficoll, polyvinylpyrrolidone (PVP) and dextran. The results of Pollack *et al.* (1965) indicated that these compounds act by increasing the dielectric constant of the medium, thereby reducing the ζ -potential. The surface charge on the cells was not affected by these materials. There is, however, more to it. Goldsmith (1974) reported his studies on the induction and enhancement of agglutination by bovine serum albumin. In an effort to understand the variable effects of different lots of albumin, it was discovered that different lots contain different amounts of polymerized albumin. The optimal conditions for

agglutination with incomplete anti-D occurred when the preparations contained 85% monomer and 15% polymer. The effect did not appear to be due to an increased uptake of antibody in the sensitization step. As for the effect on the second stage of agglutination, it turned out that some albumin preparations containing relatively large amounts of polymer could induce agglutination in unsensitized cells (false positives). And it could be calculated that the change in dielectric constant with albumin solutions containing different amounts of polymer was not great enough to account for the effect. Studies by Brooks and his collaborators are mentioned which suggested that neutral polymers (such as dextran) did not affect the dielectric constant as Pollack *et al.* had claimed, and that enhancement of agglutination might be the result of intercellular polymer bridging. There is no doubt that albumin does affect the dielectric constant of a solution, but the studies do indicate that the mechanism of enhancement by charged and neutral polymers might not be the same. Reckel and Harris (1978) have recently studied the enhancement of agglutination by polymeric bovine albumin, as compared with the monomeric form. The polymeric form was more effective in promoting agglutination.

Pollack *et al.* (1965) also carried out measurements to determine the effect of treating cells with various proteolytic enzymes. Treatment of cells with papain, ficin, bromelain or trypsin often renders them agglutinable by a specific antiserum containing incomplete antibodies which does not bring about agglutination in untreated cells. The data showed that enzyme treatment of cells brought about a significant, and fairly reproducible, reduction in the net surface charge, and thus in the ζ -potential. The probable mechanism for the change was suggested to be the removal of ionogenic surface groups from the cell membrane, most probably sialic acid. In this regard, the proteolytic enzymes mimic the action of neuraminidase (sialic acid is N-acetylneuraminic acid), and their role in the enhancement of erythrocyte agglutination by specific antibodies was believed to be attributable to their esterase activity rather than to their proteolytic activity. In the case of anti-D agglutination of D cells, enzyme treatment is known to increase the value of the equilibrium constant by two- or three-fold, and this is entirely due to an increase in k_a (Hughes-Jones, 1975). One explanation is that removal of sialic acid-containing peptide from the cell improves the accessibility of antigen sites, because the number of available sites is not substantially increased by the enzyme treatment. The increased uptake of antibody, however, does not explain the enhancement, since, at least with IgG anti-D, the amount of antibody required for agglutination of enzyme treated cells was much less than the amount that could be bound to untreated cells without any agglutination taking place. Gunson (1974) has discussed the mechanism of enhancement by enzyme treatment. He noted that the role of the ζ -potential, as put forward by Pollack *et al.* (1965) has been questioned. Studies in which the electrophoretic mobility of cells is used as a measure of the ζ -potential, and cells are separately treated with neuraminidase and then proteases indicate that neur-

aminidase treatment alone alters the zeta-potential to about the same extent as papain, but does not enhance agglutination. It is, therefore, apparently not enough to reduce the ζ -potential, or only to remove surface sialic acid residues. It has been suggested that the polypeptide stems may cause steric hindrance to antibody approach in cells treated by neuraminidase alone. Papain and other proteolytic enzymes remove mucopeptide fragments, that is, they remove the polypeptide stems along with the associated sialic acid residues.

Ionic strength is an important factor in the rate of association of antigen and antibody as well. The presence of electrolytes which interact with the charged groups on the reacting species have the effect of reducing the attractive forces between oppositely charged groups on the antigen and antibody. Since the electrostatic interactions contribute to antigen-antibody binding, the association constant k_a is increased as the ionic strength of the medium is lowered. This has been shown to be the case for a number of Rh, Kell, Duffy and Kidd system antibodies (Hughes-Jones, 1975).

Van Oss *et al.* (1978) carried out extensive studies on the mechanism of enhancement of agglutination by a variety of factors, including cell shape, cell distance, cell ζ -potential and degree of hydration of the cell surface. All of these are changed to varying degrees by the action of various soluble polymers, ionic strength, the action of enzymes and interaction with different kinds of antibody molecules. The influence of ζ -potential was said to be fairly minor, compared with cell distance and cell shape.

In addition to being brought about directly by mixing cells with specific antibodies to determinants on those cells, agglutination may be brought about in various indirect ways. Agglutination can thus be used as a tool in the measurement of antigen-antibody reactions. A number of terms are in use to describe the various situations. Agglutination may be active or passive, and either of these types may be direct or indirect. Active hemagglutination refers simply to the agglutination of red cells by antibodies directed specifically against antigens which comprise part of the cell surface. A great many serological tests are done in this way. In direct active hemagglutination, it is necessary only to mix the cells with the antibody reagent under proper conditions. In some cases, involving antisera containing large amounts of IgG antibodies, the antibodies bind the antigenic receptors of the cells, but do not bring about agglutination directly, as mentioned above. In these situations, agglutination may be brought about using specific antibodies against the IgG molecules. Known as indirect active hemagglutination, this process demonstrates the presence of the "incomplete" or "blocking" IgG antibodies on the cell's antigenic receptors. It is often called a Coombs test, after Dr. R. R. A. Coombs, who, with Mourant and Race in 1945, first described it for the detection of incomplete Rh antibodies. The antihuman globulin serum is often called Coombs serum (see Fig. 16.1). Passive hemagglutination refers to a situation in which cells are agglutinated by specific antibodies directed against soluble antigens which have been absorbed onto the cell surface.

Many polysaccharide antigens spontaneously absorb onto the red cells. Protein antigens do not readily absorb onto red cells, but will do so if the cells have been treated with dilute solutions of tannic acid at 37°. These so-called "tanned red cells" can be treated with a soluble antigen, washed, and will then be agglutinated by specific antisera against the antigen. Protein antigens can also be chemically coupled to red cells by diazotization reactions. Passive hemagglutination, like active hemagglutination, may be direct or indirect, depending upon whether Coombs serum must be employed to bring about the agglutination. Tanned red cell techniques are discussed in more detail in section 16.3. Anti-human globulin inhibition tests for the determination of the human origin of bloodstains are discussed in sections 16.2, and represented diagrammatically in Figures 16.1 and 16.2.

Studies on the temperature dependence of agglutination have resulted in the antibodies being divided into two classes, those whose reaction is not greatly affected by temperature (the "warm" antibodies), and those in which agglutination strength increases as temperature is lowered ("cold" antibodies). Present evidence suggests that the effect is primarily on the first stage of the reaction (Hughes-Jones, 1975). On thermodynamic grounds, the phenomenon may be understood on the basis of the fact that exothermic reactions proceed further to completion as temperature is lowered. The "cold" antibody reactions would be expected to be exothermic, while "warm" antibody reactions would not be expected to be exothermic (i.e., primarily entropy driven). Such data as there is indicates that those expectations are true. Williams (1971) discussed various aspects of the structure and reactivity of cold antibodies.

Zone phenomena may occasionally be observed with agglutinating antisera, depending upon the technique being used and the composition of the antiserum. If a series of successive dilutions of antisera is prepared, and tested with a constant concentration of cells, three "zones" of reactivity may be observed. At high antiserum concentrations (low dilutions), no agglutination is observed. This part of the series is often called the "prozone" or the "prezone". As the dilution of antiserum becomes greater, agglutination is observed, this segment of the series being called the "equivalence zone". At sufficiently high dilutions of the antiserum, agglutination is once again not observed, this part of the series being known as the "postzone". Agglutination is thought to take place by antigenic determinants entering into specific combination with antibody binding sites in a relatively strong, but dissociable combination. A dynamic process of dissociation and recombination then occurs until a stable network of alternating antigen and antibody molecules is formed. At the equivalence point, all the antigen and antibody are consumed in the lattice array. In the prozone, where there is excess antibody, agglutination is not observed because, when an antibody dissociates from an antigenic determinant, there is a higher probability of the vacated determinant being re-occupied by a free antibody molecule than by one which is already bound to another cell. At the

other end of the titration series, in the postzone, there is too little antibody present to bring about a complete reaction.

The term "mixed agglutination" is used in different senses. In general, it refers to the demonstration of the presence of antibodies on the surface of a cell (or other surface) which were raised in species X by noting that red cells, coated with an incomplete antibody raised to the cells in species X, are agglutinated by a linking antibody to species X immunoglobulins, raised in species Y. The antibodies one wishes to detect in this way may be bound to receptors on a red cell, a tissue surface or the surface of an object, such as a bloodstained thread. The presence of rabbit antibodies on sheep red cells could be demonstrated, for example, using sheep red cells coated with rabbit anti-sheep red cell antibodies as indicator cells, and goat anti-rabbit antibodies as linking agents. A mixed agglutination technique applied to species-specific tissue antigens is discussed in section 17. The term mixed agglutination can have a slightly more restrictive meaning as well. It refers to a general technique in which specific antibodies are used to detect the presence of antigen on a cell or other surface by virtue of cross-linking the antigen-containing cell or material to red cells containing the same antigen. Mixed agglutination may be used for determination of the ABO groups in bloodstains (Section 19.10.3.5), body fluid stains (Section 19.10.5.2) and tissue cells (Section 19.10.5.3). A mixed agglutination test for species of origin can be done as well. The technique employs anti-human globulin (AHG or Coombs) serum, and is based on the presence of human globulin in a bloodstain of human origin. The method, called "mixed antiglobulin technique" by its originators, is discussed in Section 16.4 and diagrammatically represented in Fig. 16.3. The term "mixed hemagglutinative system" was used in the past in an entirely different context. Hooker & Boyd (1937) employed the term to describe a system in which a mixture of human and chicken red cells were agglutinated simultaneously by anti-human and anti-chicken agglutinin sera. The experiments were based on earlier studies by Topley *et al.* (1935) who had studied a similar system using different strains of bacteria and their corresponding agglutinins. Wiener and Herman (1939) extended these studies. Because of this earlier meaning of the term "mixed agglutination" in the literature, Akaishi (1965) argued that the method for determining the ABO group in bloodstains by cross-linking the indicator cells with the antigenic determinants on the stained material, as first elaborated by Coombs and Dodd (1961), should be called "group specific double combination method". The Japanese workers have tended to use Akaishi's term rather than "mixed agglutination" in the literature. Other terms, which are introduced in the sections devoted to the particular application, have been used in the literature as well.

Agglutination of inert particles coated with antigen is also possible with specific antibodies. The particles serve as inert carriers of antigen in these cases. Latex particles are used for a number of tests, and this subject is discussed in connection with its medico-legal applications in Section 16.5.

If the conditions for carrying out a serological test are to be optimized, the concentrations of antigen and antibody must be adjusted so that maximal antigen-antibody interaction takes place. It is customary to test the strength of an antiserum by preparing a series of doubling dilutions of it, and testing these with a constant concentration of cell suspension (antigen), the last tube in the dilution series showing agglutination being called the *titer*. With red cell antigens, this technique is about the only one available for estimating the strength of an agglutinating antiserum. It should be recognized, though, that it is fairly crude. Antisera will vary in their content of various immunoglobulin types, which in turn vary in their valencies. The proportions of complete and incomplete antibodies may vary from one antiserum to another. And antibodies vary in their binding potency toward an antigenic determinant. Antisera consist of a population of antibodies which, although they possess the same immunological specificity, vary in their reactivity with the antigen. This property has been called the "antibody spectrum". A closely related concept is that of so-called "avidity" of antibodies. Avidity refers to the strength with which antibody binds to its antigenic receptor. The speed with which an agglutinin serum brings about agglutination has been taken as a measure of its avidity. The notion of avidity was first applied to antitoxic sera, based upon the observation that the curative effect of antitoxic sera did not always parallel their antibody content. Jerne (1951) carried out extensive studies on this subject. The term "avidity" is still used to describe the affinity of antibodies for their antigenic receptors. The titer obtained with an agglutinin serum depends upon the conditions employed, because many antisera contain mixtures of antibodies with different characteristics. An antiserum will frequently yield different titration values, depending upon whether the tests were carried out in saline, in the presence of protein media or other colloids, by the Coombs technique, or with enzyme treated red cells. These factors must be taken into account in evaluating an antiserum for any particular kind of test. Depending upon the conditions under which the tests are carried out, terms such as "saline titer", "albumin titer" or "papain titer" are sometimes used. In medico-legal work, evaluation of an antiserum will be based on the intended application, e.g. whether it is to be used for grouping whole cells or dried bloodstains, which blood group system is under consideration, which technique is to be used, and so forth. Evaluation of antisera for particular medico-legal applications will be discussed further in connection with the applications and systems themselves as they come up in subsequent units.

1.3.4.2 Precipitation. Precipitating antibodies are of importance in medico-legal investigations, the use of precipitin sera against species-specific proteins being the most widely employed method for determination of the species of origin of blood or body fluid stains (see section 16.1). Precipitin sera directed against specific body fluid proteins may be employed to identify the body fluids as well (see sections 7.1, 10.3.1, 11.4 and 12.7).

Precipitation may be regarded as a second stage in an antigen-antibody reaction in the same way as was agglutination, the first stage consisting of the combination of specific antigen with specific antibody. Assuming that the antigen/antibody ratio is within the optimal range, precipitation then occurs due to extensive cross linking between antigen-antibody complexes. Precipitation occurs in part because of the large size of these lattice structures, and also probably because the combination of antigen with antibody masks some of the polar groups which are important in maintaining macromolecules in solution, and thus allows aggregation through the interaction of apolar groups.

Precipitin systems exhibit zone phenomena. Because precipitin sera very quickly become ineffective upon dilution, it is the usual practice to carry out successive dilutions of antigen and test them with constant, relatively high concentrations of antisera. In a titration series, therefore, antigen is ordinarily in excess in the first few tubes, and antibody is in excess at the end of the series, this in contrast to the situation in titrating agglutinin sera where the antibody is diluted, and where antibody excess thus occurs at the beginning of the series. Therefore, what would be called a "prozone" in the terminology of agglutinin titrations where antibody is in excess, would occur at the end of a precipitin titration series. For this reason, a prozone on a precipitin titration, so named because it occurs at the beginning of the series, may correspond to a postzone in an agglutination titration.

Classically, the amounts of precipitate obtained were determined quantitatively by measuring the total antibody-nitrogen in the washed precipitate by means of the Kjeldahl method. With polysaccharide antigens, total-N was a direct measure of antibody, since the polysaccharides contained no nitrogen. In the case of protein antigens, the N-contribution of the antigen had to be subtracted from the total. It is now more common to carry out quantitative precipitin tests by turbidimetric techniques. One of these, the method of Boyden and his collaborators, is discussed in section 16.8. Another method which has been employed for determining the optimal proportion of reagents is determination of the velocity of precipitate formation. This procedure has been carried out in two ways, the first employing constant concentration of antiserum and varying antigen, and the second, varying the amount of antiserum while holding antigen constant. The former is sometimes referred to as the Dean and Webb procedure (Dean and Webb, 1926), while the latter is called the Ramon technique (Ramon, 1922a, 1922b, 1922c). Marack (1938) referred to Dean and Webb's technique as the α procedure, and to Ramon's as the β procedure, this terminology being occasionally encountered in the literature. Ordinarily, it is found that the optimum obtained by the α -procedure is not the same as that obtained by the β -procedure using the same serum. Boyd (1941) pointed out that most precipitin antisera could be categorized into one of two classes, R or H, based on their behavior in α - or β -procedure titrations. R-type antisera give only one optimum, this with the α -procedure. H-type antisera give optima with both procedures. H-type antisera were originally

designated as such, because they were typified by a horse antitoxin serum, while R type behavior characterized many antisera prepared in rabbits. It is not universally true, however, that all rabbit antisera are of the R type, nor that all horse antisera are of the H type. Boyd (1966) discussed this matter in his text as well. Because H type antisera tend to inhibit precipitation when present in excess, it has been common to prepare antisera to species-specific serum proteins in rabbits for medico-legal testing. This matter is taken up in section 16.1.1. It may be noted also that the optima obtained with the α - and β -procedures, which are based on the *velocity* of the reaction, do not necessarily correspond to the equivalence zone as determined by the *amount* of precipitate obtained with varying concentrations of antigen and antibody.

It is common today to conduct precipitin tests in gel media. The development of these techniques is discussed in section 16.1.2. Immunoelectrophoresis and immunodiffusion are also discussed in section 2.

1.3.4.3 Radioimmunoassay. Radioimmunoassay (RIA) has become an important technique in the assay of a variety of biological materials. The method combines the specificity of antigen-antibody reactions with the sensitivity afforded by the use of radioactively labelled tracers. A properly constructed radioimmunoassay can be extraordinarily sensitive. The method is discussed briefly in this section, because RIA assays of steroid hormones have been applied to the medico-legal determination of the sex of origin of bloodstains.

In theory and in practice, RIA may be carried out using either radiolabelled antigen or radiolabelled antibody. Assays in which radiolabels have been introduced into antibodies have been described, but those employing radiolabelled antigen or hapten have been more common. In applying the method to low MW molecules, it is generally easier to introduce the label into the hapten than it is into the antibody.

Determination of the concentration of some material by RIA (assuming radioactive antigen or hapten is to be used) requires a specific antibody to the antigen or hapten, radioactively labelled antigen or hapten, and unlabelled antigen or hapten. A method for separating antibody-bound antigen or hapten from unbound material is also required. The assay is based on the ability of unlabelled antigen to inhibit competitively the binding of radioactively labelled antigen by the antibody. Labelled and unlabelled antigen are incubated under proper conditions with antibody, and the antibody-bound antigen is separated and counted. By carrying out a series of measurements in which the amount of unlabelled antigen is varied, a standard curve can be constructed. The standard curve relates the counts observed to the amount of antigen present in the sample over a range of antigen concentration. There are a number of different ways of handling the data to plot the standard curve. The amount of antigen or hapten in an unknown sample may then be determined by reference to the standard curve, or, by suitable computational manipulation of the data, by calculation from the standard curve data.

There are many practical details and problems associated with radioimmunoassay procedures. A good general reference to the technique is Parker (1976). Details of more specific applications may be found in Luft and Yalow (1974). Steroid and steroid hormone RIA methods are discussed in detail in Abraham (1974) and in Jaffe and Behrman (1974).

1.3.5 Complement and complement-mediated reactions

1.3.5.1 Introduction. Complement is a collection of proteins in serum which, acting in concert, participate in a variety of immunological reactions. The complement system may be activated under suitable conditions, and will combine with antigen-antibody complexes to give irreversible structural and functional changes in membranes and cell death, or to activate various specialized cell functions. The components of complement react in a particular order, the overall reaction sometimes being referred to as the complement sequence, or the complement cascade. The reaction of the complement components with an antigen-antibody complex is also referred to as "complement fixation". One of the more striking activities in which complement participates is red cell lysis, or hemolysis. It has been common, therefore, to use red cells, sensitized with an antibody to a membrane antigen, as a hemolytic indicator system. If an antigen-antibody reaction has been allowed to take place in the presence of complement (many vertebrate sera contain complement, but guinea pig serum is a particularly rich source), the mixture can then be tested to see whether complement is still present. A common indicator system is sheep red cells, sensitized with rabbit antibody. If hemolysis occurs upon addition of the indicator cells, complement is still present, but the absence of hemolysis indicates that complement has been "fixed" in the original antigen-antibody reaction. This kind of procedure is known as a complement fixation test. Complement fixation tests have been used in medico-legal tests for species of origin, and this subject is discussed in greater detail in section 16.6.1.

Complement has had a number of different names. Buchner (1899 and 1900) had first referred to it as "schutzstoff", but introduced the name "alexine". The latter term was adopted by Bordet and his collaborators (see, for example, Bordet and Gay, 1906). Ehrlich and Morgenroth (1899a and 1899b) had first referred to complement as "ad-diment", but introduced the term "complement", which has persisted to the present time, soon afterward.

1.3.5.2 Nature and properties of complement. There are now known to be two operationally distinct complement pathways, each composed of a number of different proteins. The classical pathway, activated by IgM or IgG complexes, consists of 11 proteins which have been grouped into three functional units. The recognition unit is composed of components C1q, C1r and C1s, the activation unit consists of C2, C3 and C4, and the membrane attack unit consists of C5 through C9 (Müller-Eberhard, 1975). The alternative, or properdin pathway, activated by IgA aggregates and by

polysaccharides and lipopolysaccharides, consists of 5 proteins, one of which is C3. The alternative pathway bypasses C1, C2 and C4 and acts on C5–C9 in the same manner as the classical pathway. In addition to the proteins already mentioned, there are several others involved in the system as well. The remainder of the discussion deals with the classical pathway.

The components of the complement system are designated C1, C2, C3, etc., through C9. They were formerly designated C'1, C'2, C'3, etc., through C'9. The three sub-components of C1 are designated C1q, C1r and C1s. Physiological fragments of components, which result from cleavage by enzymes within the complement system, are distinguished by lower case arabic letters, e.g. C3a, C3b. If a component, or composite product consisting of a number of components, possess enzymatic activity, a bar may be written above the component(s) in which the enzymatic activity resides. The complement cascade sequence is indicated in Fig. 1.43. This scheme gives but a brief notion of the sequence of events, and is a great oversimplification of the molecular complexity of the system. C1 is a Ca^{++} -dependent complex of C1q, C1r and C1s, and reversibly combines with IgG or IgM. Recognition of the immunoglobulin resides in C1q. The C1q binding site resides in the Fc fragments of IgG or IgM. C1q binding initiates a change in C1r, which acquires enzymatic activity and converts C1s to C1s. C1s can act upon C4 and C2 yielding C4a, C4b, C2a and C2b fragments. C4b can bind EAC1 and C2a can bind EAC14b to form EAC14b2a. The $\overline{\text{C42}}$ complex is a C3 convertase, which cleaves C3 into C3a and C3b. C3b can bind EAC14b2a. The interaction of C3 with C3 convertase gives rise to a $\overline{\text{C423}}$ complex which is a C5 convertase, yielding C5a and C5b from C5. The attack on C5 by its convertase initiates a self-assembling process which gives rise to a stable C5b–C9 complex without further enzymatic intervention. The complete complex on the membrane gives rise to the ultrastructural lesions which are the underlying cause of cell lysis. It is to be noted that the various complement components and fragments are known to be involved in other immunological reactions in which the complement system participates. C5a and C3a, for example, participate in anaphylactic release of histamine from mast cells, leading to an increase in capillary permeability. A brief, highly readable review of the complement system was given by Meyer (1976) and a somewhat more involved review was done by Müller-Eberhard (1975).

1.3.5.3. Complement fixation. The major reason for discussing complement fixation is that it can be used as an indicator of antigen-antibody reactions. In general, it is exceedingly sensitive, and is often the method of choice in particular tests. It is common to use sheep red blood cells which have been sensitized with rabbit antibody to them. The antibody, or hemolysin, was called "sensibilisatrice", or "sensitizer" by Bordet and his collaborators (Gengou, 1902; Bordet and Gay, 1906). Ehrlich and Morgenroth (1899a) referred to the hemolysin as the "immunkörper", or immune

body, at first, following Pfeiffer's terminology. They later called it the "interbody", and in 1901, introduced the term "amboceptor" which persisted in the literature for quite some time. Complement is very labile, and complement fixation tests must be carried out with careful attention to the proportions of reagents used.

A *unit* of complement is usually taken as the smallest amount which will produce complete hemolysis at 37° in a specified amount of time with specified quantities of cells and amboceptor. Amboceptor concentration must be adjusted so that it is not present in excess. Guinea pig serum is the best source of complement for the sheep red cell hemolytic system. Complement must be titrated each day. Complement fixation tests may be qualitative or quantitative. The quantitative methods are based on the measurement of the Hb released from a fixed amount of red cells spectrophotometrically. Such techniques can be used to carry out titrations of unknown antigens for which pure antibody is available, and vice-versa, since there is a direct relationship between the extent of antigen-antibody reaction and the amount of complement fixed. Complement may be fixed *in vivo* in circumstances where immunological reactions are taking place, whether these be in defense against infectious agents, or in pathological conditions.

1.3.6. Hypersensitivity

Although hypersensitivity is not directly related to most current medico-legal applications of immunology, it constitutes an important area. Hypersensitivity tests have been proposed for medico-legal applications in the past, and although they are impractical and were never widely employed, they are of some historical importance (sections 10.3.2. and 16.6.2).

Hypersensitivity refers to a state of increased reactivity to a foreign agent based on prior exposure to the same or a chemically similar agent. The term *allergy* is often used synonymously, although originally it had a broader meaning. A wide variety of substances can induce hypersensitivity, and the generic term *allergen* is sometimes employed to designate these materials. Sensitization requires one or more exposures to the allergen, a latent period and a subsequent exposure which elicits the reaction. Originally, hypersensitivity was classified as *immediate* or *delayed*, depending upon the speed with which a sensitized individual displayed a reaction to the inciting agent. It is now clear that the mechanisms of the immediate and delayed types of hypersensitivity are different. Immediate hypersensitivity is antibody mediated, while delayed hypersensitivity is cell mediated. Reaction in the former case is the result of the specific interaction of specific antibodies with the allergen, and sensitivity can be transferred passively to a normal individual by transferring serum from a sensitized one. In delayed hypersensitivity, the triggering event involves the interaction of allergen with antibody-like receptors on the surfaces of sensitized lymphocytes. The transfer of serum from a sensitized individual to a normal one does not bring about the passive transfer of delayed type hypersensitivity.

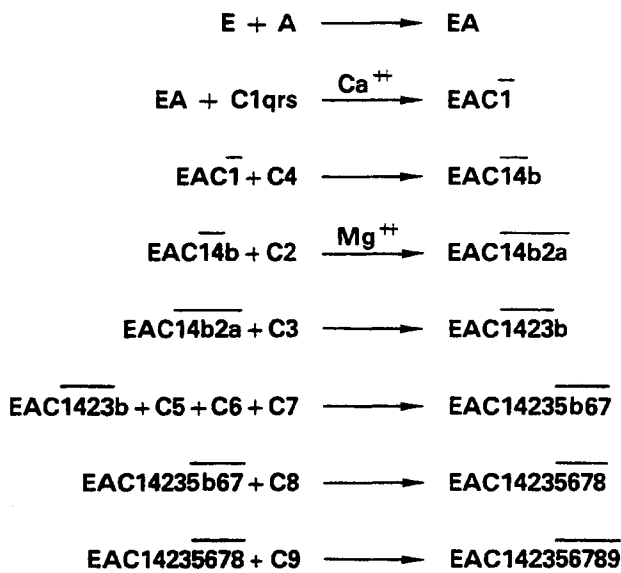


Figure 1.43 The Complement Cascade. E = red cell
 A = antibody (Igm or IgG) C1 through
 C9 = complement components

1.3.6.1. Immediate hypersensitivity. Immediate hypersensitivity reactions are due to humoral antibodies combining with a specific antigen, and resulting in the production of cell injury and inflammation. Examples of this type of hypersensitivity include anaphylaxis, atopic disease and serum sickness.

Anaphylaxis is a term which originated with Portier and Richet in 1902. They attempted to immunize dogs against toxic extracts of eel serum or sea anemone tentacles. Re-injection of the substance some weeks later, even with doses sublethal to normal animals, resulted in violent illness and death. Since this phenomenon represented the reverse of prophylaxis, or protection, they termed it "anaphylactique". It is now clear that a variety of antigens can bring about anaphylactic reactions. The first, or sensitizing, dose is given intradermally, intraperitoneally or intravenously. Antibodies develop over the course of the ensuing 2 to 21 days, and are present in serum as well as being fixed to cells in some tissues. The second injection, called the shocking, or challenging, injection, is given intravenously or intracardially, or may be given by aerosol, and the dose is usually several times greater than was the sensitizing dose. Antigen reacts with the cell-fixed antibodies, causing mediators to be released which then give rise to the pathological symptoms.

The symptoms can be characteristic primarily of one or a few organs, or can be virtually systemic, depending upon the species of animal, the mediators and so forth. Anaphylaxis in human beings is mediated by IgE immunoglobulins with rare exceptions.

Atopic diseases are mainly common allergies, such as hay fever, asthma and eczema, and represent another kind of immediate hypersensitivity reaction. The antibody involved in these syndromes, IgE, was classically termed "reagin". Human reaginic antibody does not appear to be artificially inducible with antigen. It develops as the result of natural exposure to the antigen in certain persons, presumably because of their genetic constitution. A rare, but illustrative example of immediate hypersensitivity is provided in the cases described by Reunala *et al.* (1977) in which two young women exhibited severe, IgE-mediated allergic reactions to human seminal plasma protein.

Other examples of immediate hypersensitivity include the so-called Arthus reaction and serum sickness. The Arthus reaction was first described in rabbits after a series of injections of antigen. The reaction is localized around the site of the injection and involves vascular injury. Serum sickness is the systemic counterpart of the Arthus reaction, and results from the administration of heterologous serum. The illness has a characteristic set of symptoms, generally runs its course in about a week, and is ordinarily not fatal.

1.3.6.2 Delayed hypersensitivity. The delayed hypersensitivity reaction is, like the immediate type one, mediated by non-antibody substances, but the initial event is the interaction of the specific antigen with antibody like receptors on the surface of sensitized lymphocytes, rather than with humoral antibodies. The reaction is characterized by a slowly evolving inflammatory response at the site of injection in a previously sensitized individual. A variety of antigenic and haptenic materials can induce this type of hypersensitivity, and intradermal injections are much more effective in promoting sensitivity than are intravenous ones. Incorporation of the antigen into an adjuvant enhances production of the hypersensitive state. The reaction is mediated by the T-cells. The lymphocyte population mediating the delayed hypersensitivity response is capable of producing a variety of mediator substances which are not themselves antibodies. They bring about a variety of biological effects, and are collectively called *lymphokines*.

It should be noted that the reactions described in the foregoing sections do not always occur in isolation from other reactions. Complex reactions, involving both types of hypersensitivity response, are possible, and it is not always easy to determine exactly what the observed symptoms mean in terms of the underlying immunological mechanisms.

SECTION 2. SURVEY OF SELECTED METHODS

2.1 Introduction

Any of scores of chemical, biochemical or immunological methods may be applied in various circumstances to particular medico-legal case studies. A number of these, particularly the electrophoretic and immunoelectrophoretic ones, tend to be especially applicable in forensic biology, and the focus of this section is on them. As with the background material generally, the treatment of the methods is not comprehensive nor fully documented. Discussion of specific techniques has generally been placed in subsequent sections in the context of their application.

2.2 Immunodiffusion

The development of immunodiffusion techniques is discussed in section 16.1.2, in connection with the "precipitin test" for species of origin. Immunodiffusion is, in effect, any technique in which a precipitin antibody and its precipitinogen are allowed to diffuse together, forming a precipitate and thereby indicating that antigen has reacted with antibody. Immunodiffusion may be done in solution or on a variety of support matrices. If one of the reactants is stationary while the other diffuses, the technique is called single diffusion. If both reactants are diffusing, the technique is called double diffusion.

2.2.1. Single immunodiffusion

Single diffusion techniques were developed first. These tests are often carried out in gels, and may be linear or circular. Classically, the linear test involved allowing antigen to diffuse into an agar gel containing antiserum. Antigen concentration is usually in great excess. The diffusion of antigen into the antibody-containing gel causes a precipitin band to form and, as diffusion progresses, the precipitin band will be dissolved by excess antigen but will re-form further into the gel. The precipitin band will thus appear to be moving through the gel. If the antigen concentration is balanced with respect to the antibody concentration, the band will form and remain at or near the interface. The rate of precipitin band movement in the system described, with antigen diffusing, is directly proportional to the antigen concentration and inversely proportional to the antibody concentration. If antigen concentration is in excess, the distance of the precipitin band movement is linearly proportional to $\sqrt{\text{time}}$. The slope of the line at any particular antigen concentration is linearly related to antibody concentration. These relationships hold only within certain concentration ranges, however. Many factors influence the formation and apparent migration of the precipitin band. Further details of this technique are discussed by Crowle (1973).

The radial technique differs somewhat from the linear one. Diffusion of excess antigen is usually allowed to proceed radially into an antibody containing gel. A disc of precipitate forms and appears to expand outwardly until the front of the diffusing reactant has reached equilibrium with the antibody. Except at the early stages, the rate of movement is not proportional to $\sqrt{\text{time}}$. The final size of the disc of precipitate, however, is linearly related directly to the antigen concentration, and inversely to antibody concentration (Mancini *et al.*, 1965). Hill (1968) should be consulted for theoretical considerations in radial immunodiffusion. Quantitative methods have been treated by Berne (1974) as well. Single diffusion tests have, for many applications, been replaced by double diffusion and immunoelectrophoretic techniques.

2.2.2. Double immunodiffusion

Double diffusion tests can be performed in tubes or on surfaces. On surfaces, the antigen and antibody can be placed in rectangular wells at 90° to one another, or in a variety of circular well arrangements where diffusion is radial. The number of bands formed in the test is interpreted as the minimum number of precipitating systems present, but does not necessarily represent the maximum number. As diffusion proceeds, steep gradients of each reactant form on either side of the precipitin zone. This factor tends to compensate for excesses in concentrations of one or the other reactants, although the position of the final band will vary depending upon the degree to which one reagent was initially in excess. The test, by its nature, tends to compensate for imbalances in the concentrations of reactants, within reasonable limits. The resolution and sensitivity of the test depend on there being sufficient quantities of reactants present at the position where the diffusing species meet, and sufficient time being allowed for this to occur, given a certain distance between the wells.

Double diffusion tests have been used to compare antigen identity. Interpretation of double diffusion patterns in terms of antigenic identity or nonidentity requires caution. The simplest cases are indicated in Fig. 2.1. A triangular arrangement is often employed for the wells. Antisera to one of the antigens is placed in one of the wells. The other two are occupied by homologous antigen and the antigen one wishes to compare with it. Fig. 2.1a shows the fusion or identity pattern. If antigen concentrations are not equal, a skewed identity pattern (Fig. 2.1b) may be the result. Non-identical antigens, compared with an antiserum containing antibodies to each of them, give independent precipitin lines which intersect (Fig. 2.1c). The partial identity, or partial fusion, pattern (Fig. 2.1d) results when the non-homologous

antigen cross reacts to some extent with the antiserum to the homologous antigen. The size of the "spur" is related to the degree of cross reactivity. A double spur pattern (Fig. 2.1e) may form if two different antigens which are related to a third antigen are compared, and the antiserum is to the third antigen. The patterns indicating antigenic identity were originally called "identity patterns", but the term "fusion" is probably more preferable, since it describes the observation, rather than indicating its interpretation (Ouchterlony, 1968; Crowle, 1973). Many factors influence the formation and patterns of the precipitin lines in these systems, and there are known exceptions to the simple cases outlined above. Care must therefore be exercised in drawing conclusions about the identities of antigens based solely on double diffusion precipitin patterns.

Precipitin lines may be curved, and this behavior ordinarily reflects differences in the diffusion coefficients of the reactants, although parameters such as salt concentration can influence the outcome as well. There are many variations of the double diffusion test, and these are discussed in the specialized references (Ouchterlony, 1968; Crowle, 1973). Immunodiffusion techniques are less widely employed than before because of the improvements in immunoelectrophoretic methods.

2.3 Electrophoresis

2.3.1 Introduction

Electrophoresis is the movement of charged particles in solution under the influence of an electric field. The technique for electrophoresis of proteins was devised and perfected by Tiselius (1930 and 1937) in liquid medium, an achievement for which he was awarded the Nobel Prize in chemistry in 1948. This technique is often called "moving boundary electrophoresis", "free electrophoresis" or the Tiselius technique (Longworth, 1959). The method has been almost entirely supplanted by techniques employing stabilizing media. These provide a matrix for the buffer in which the proteins travel, and serve as a "trap" for the separated proteins so that they can be detected, compared and examined. Paper, cellulose acetate, agar and agarose gels, hydrolyzed starch gels, polyacrylamide gels, ion exchange resins, sephadex and other molecular sieving media, and a number of other materials have been employed as electrophoretic media. Electrophoresis in stabilizing media is usually called "zone electrophoresis".

2.3.2 Factors influencing migration and separation

The fact that proteins are electrolytes allows them to be separated by electrophoresis. Net charge on proteins is a function of pH, and so, therefore, is their electrophoretic mobility. It was originally thought that buffer solutions used in electrophoresis served mainly to maintain the medium at constant pH, and insure that the polyelectrolytes retained constant charge throughout the experiment. While that is indeed true, the buffer ions can have other effects as well.

Some types of buffer ions bind to proteins and alter their electrophoretic mobility. Concentration of buffer is important too. The more concentrated the buffering solutions, the more current will be carried by buffer ions, and the slower the separating compounds will be expected to migrate. Separation zones are often found to be sharper in more concentrated buffering solutions, however. Some workers quote the ionic strength of buffer solutions, rather than their concentration. Ionic strength is defined as

$$\mu = \frac{1}{2} \sum m_i c_i^2$$

where m_i is the molality of the i^{th} component and c_i is its charge. Sometimes, the term "ionic strength" is used incorrectly in describing buffers, and it is necessary to read methodological descriptions carefully so that concentration and ionic strength are not confused with one another. Support media offer a resistance to current flow which is a function of the medium, the type of buffer employed and its concentration. This resistance causes heat to be generated during electrophoresis in accordance with $H = i^2 R / 4.18$, where H is the heat generated in cal/sec, i is the current and R is the resistance. Heating of the support matrix causes resistance to decrease over the course of time. The rate of migration of the separating species therefore increases, and in constant voltage experiments, current increases as resistance decreases. Heating also causes evaporation of water from the support, generally decreasing resistance and increasing migration rates. The resistance of a strip of supporting medium is a function of its length, and voltages used for electrophoretic separations should be quoted as "per unit length", generally in V/cm. At lower voltages, with thin support media, such as paper or cellulose acetate membranes, heating may not present a serious problem. With gels, however, it is often necessary to provide for continuous cooling to prevent thermal gradients from developing within the medium. The resistance of the medium is equal to the sum of the resistances of all the individual components, including the wicks. The applied voltage, as read from the power supply unit, is not necessarily therefore the actual voltage being applied across the medium.

Another important effect in zone electrophoresis, resulting from the interaction of aqueous buffers with the support media, is called electroendosmosis, or electroosmosis. Water molecules become positively charged with respect to the support medium, and so stream toward the cathode carrying with them buffer ions and components of the mixture. In the case of many proteins, which have acidic pI, electroendosmotic flow is in the opposite direction to electrophoretic movement. Slow moving proteins, such as the γ -globulins, may be carried back toward the cathode, and thus appear to have moved in the direction opposite to that expected. Neutral molecules may be employed to determine the electroendosmotic properties of a medium. Glucose, urea or a variety of other molecules can be used to determine this effect for small molecules, and blue dextran can be used to test it for macromolecules. Different support media vary in

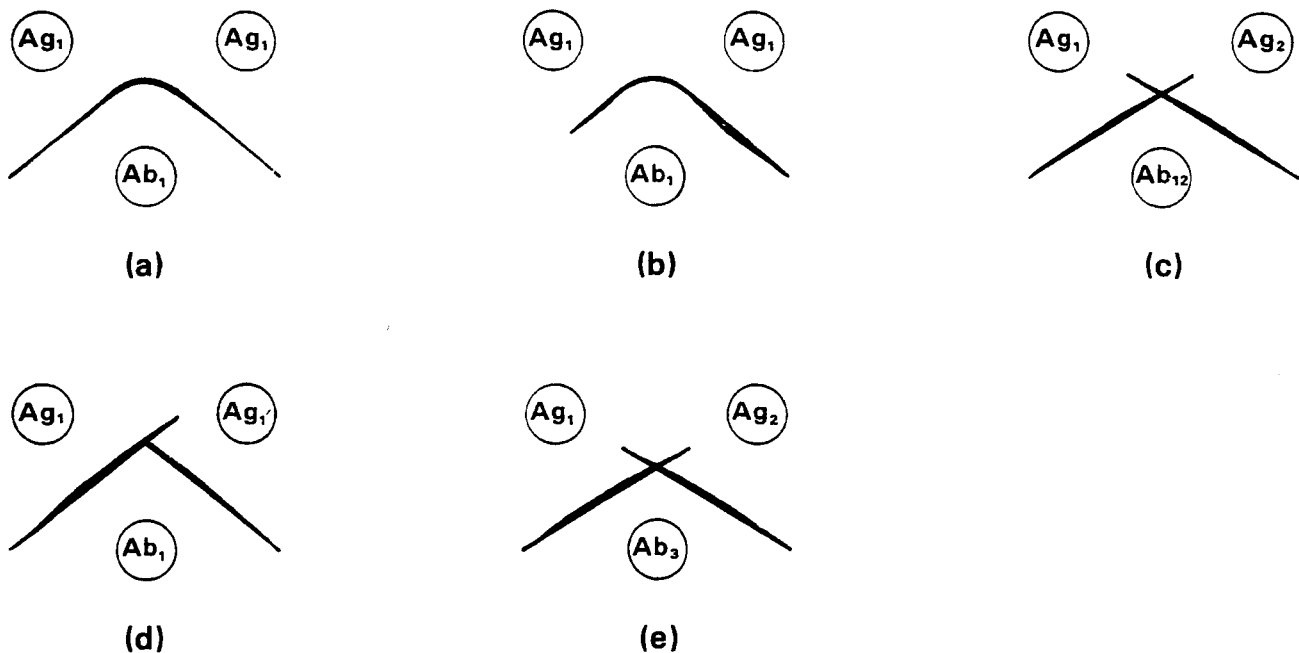


Figure 2.1 Precipitin Patterns in Double Diffusion Tests. Ag-antigen Ab-antibody Subscripts denote sameness or dissimilarity (see text).

their electroendosmotic properties, different types of agar probably being the most variable in this respect.

2.3.3 Paper electrophoresis

Paper was the first support medium employed for electrophoresis. The technique is still useful for smaller molecules. It is applicable to macromolecules as well, but the gel methods have largely supplanted its use for this purpose. According to Wunderly's (1959) review, König first suggested paper as a support medium for electrophoresis in 1937. Development of paper electrophoresis therefore preceded the development of paper chromatography, which grew out of the studies of Consden *et al.* in 1944. By 1950, the investigations of a number of workers had resulted in a clearer understanding of the technique, and its applicability to the study of inorganic ions (McDonald *et al.*, 1950; Kraus and Smith, 1950), as well as to amino acids, proteins and other macromolecules (Turba and Enekel, 1950; Durrum, 1950; Cremer and Tiselius, 1950). A definitive paper on the paper electrophoresis of proteins by Kunkel and Tiselius appeared in 1951. Further details on the development of paper electrophoresis may be found in Wunderly's review (1959) and in Smith (1968).

2.3.4 Starch gel electrophoresis

Electrophoresis on starch gels has become an important technique in forensic biochemistry because of its wide applicability to a variety of polymorphic isoenzymes of the red

cell (Cf. Unit VI). In 1952, Kunkel and Slater investigated a number of possible support media for zone electrophoresis, including glass beads and powders, special sands, resins and hydrolyzed starch. They found starch to be especially useful because of its low absorption properties for proteins. Their studies were carried out in starch gel blocks. Schoch (1961) has discussed the physicochemical basis for the gellation of starch suspensions. In 1955, Smithies reported that he had perfected a zone electrophoretic technique on starch gels which had good resolving power for serum proteins (Smithies, 1955a). The detection of proteins was also a relatively simple matter in this system. The gels were capable of resolving what we now know were the polymorphic variants of serum haptoglobin. This aspect of his studies was expanded (Smithies, 1955b), but a discussion of serum protein polymorphism will be deferred to Unit VII. Resolution of serum proteins could be greatly improved by a two dimensional technique, in which electrophoresis was first carried out on a paper strip, and the strip inserted into a starch gel in such a way that the direction of electrophoresis in starch was at right angles to that on the paper (Smithies and Poulik, 1956; Poulik and Smithies, 1958). In 1957, Dixon and Smithies showed that starch gel electrophoresis could be used to resolve enzymes in a mixture. The early techniques employed horizontal gels, and samples were usually applied on some type of support (e.g. filter paper) which was inserted into a precut slot in the gel. Smithies (1959a) reported that resolution could be improved using a vertical system in

which the samples were inserted directly into the gel. Early studies were generally carried out using boric acid-NaOH buffers. In 1957, Poulik introduced a discontinuous buffer system for starch gel electrophoresis which improved resolution and sharpened the separated zones. The bridge buffer was boric acid-NaOH, but a tris-citrate gel buffer was employed. In this system, the borate is fast moving, and a borate-tris interface appears and moves in the gel, eventually overrunning and passing the proteins. A voltage discontinuity exists at the interface which results in band sharpening. Wieme (1975) has discussed the theory of discontinuous buffer systems. The enhanced resolution of proteins on starch gels, as compared with paper and some other supports, is due in part to the pore structure of the gel. There is some molecular sieving effect with starch gels, depending upon the gel concentration and the molecular size of the proteins which are being separated. Smithies (1959b) reviewed the early work on starch gel electrophoresis of serum proteins.

Starch gel techniques have been widely applied to the separation of a wide variety of macromolecules. Details may be found in Smith (1968), Kunkel and Trautman (1959) and Michl (1975). Sometimes it is desirable to use denaturing gels, which are acidic, incorporate protein denaturing agents or both. Azen *et al.* (1966) carried out detailed studies to determine the most suitable buffers in such systems. Until 1968, starch gels used for electrophoresis were several mm thick. Various techniques were used to slice the gels along their long axis in order to stain the separated proteins. Gel slicing can present problems, and thicker gels are more difficult to keep cooled during electrophoresis. In 1968, Wraxall and Culliford showed that many of the separations could be carried out on thinner (about 1 mm) gels, and that these were both easier to cool during electrophoresis and did not require slicing prior to staining. Thin gels are applicable to a variety of polymorphic enzymes of the red cell, and are preferred where resolution is adequate.

2.3.5 Agar gel electrophoresis

According to Wieme (1965), the work of Field and Teague (1907a, 1907b) is often cited as the first in which electrophoretic separation was achieved on an agar gel. Because of the experimental set-up used, however, those workers were observing electroendosmosis rather than electrophoresis. The first unequivocal electrophoresis experiments on agar gels were those of Kendall (1928) with inorganic ions. Electrophoresis of proteins in agar gels was first reported by Gordon *et al.* in 1949.

Agar is a polysaccharide derived from the cell membranes of red algae. For a long time, its composition was not well defined. Studies on the structure of agar have been carried out, but its structure is sufficiently complex that information is still being developed. Commercially available examples of agar are, therefore, not normally well defined chemically, and may vary from supplier to supplier and even from lot to lot.

Araki's extensive studies on the structure of agar suggested that it was a mixture of two polysaccharides, which were called agarose and agarpectin, by analogy to amylose and amylopectin. Agarose is the simpler, being a linear molecule and said to consist of repeating units of β -D-galactopyranose and 3,6-anhydro-L-galactose. Agarpectin was more complex, and contained sulfate and uronic acid residues (Araki, 1937; Araki, 1956; Araki and Arai, 1956).

Duckworth and Yaphe (1971a, 1971b) have indicated that the two component composition concept is probably oversimplified. Their studies showed that agar is a complex mixture of polysaccharides with three extremes of structure: neutral polysaccharide; pyruvated polysaccharide with little sulfation; and sulfated galactan. Agarose is not regarded by them as a neutral molecule, but rather as a fraction with low charge and, therefore, good gelling abilities. Sulfate is not required for gelation of agar, but the electroendosmotic properties of agar gels are related to the sulfate content. Fractions which have little or no sulfate do not exhibit electroendosmosis. Because of the chemical variability of the material, commercial preparations should be evaluated for their applicability to particular procedures. Rees (1972) has discussed the molecular mechanisms involved in the gelation of complex polysaccharides, including agar.

Agarose gels do exhibit pronounced molecular sieving effects, depending upon the concentrations employed. Such gels can be used for molecular sieving chromatography (Hjerten, 1962a and 1962b). At the concentrations normally employed for protein electrophoresis, however, the sieving effect is minimal and less important than in starch gels. Agar gels often exhibit pronounced electroendosmosis, and this factor must be taken into consideration in selecting support media for particular applications. The electroendosmotic flow can be measured by subjecting a neutral molecule, such as blue dextran, to electrophoresis in the gel. In some cases, a certain level of electroendosmosis is required to achieve the desired result, such as in the case of crossed over electrophoresis on agar gels for determination of species of origin (see section 16.1.2). In this test, the immunoglobulins exhibit a net cathodic migration because of electroendosmosis, even though their intrinsic electrophoretic mobility is slightly anodic. In the absence of electroendosmosis, the antigen and antibody would migrate in the same direction. The best single reference work on agar gel electrophoresis is that of Wieme (1965) which should be consulted for further details.

2.3.6 Cellulose acetate electrophoresis

Cellulose acetate for electrophoresis is prepared by making "membranes" or "foils" from cellulose acetylated with acetic anhydride. Different cellulose acetates vary in the degree of acetylation. The membranes consist of a three-dimensional network of interlocking pores. Sometimes, the manufacturer supplies the "foil" itself with no inert support, or sometimes the foil is bonded to an inert supporting material such as a plastic. Cellulose acetate membranes are

rather brittle when dry, but acquire a gel like appearance and lose their brittleness when saturated with buffer solutions. The properties of cellulose acetate, such as pore size, density, thickness, and so forth, can be controlled quite well, making the medium chemically well defined and fairly uniform from batch to batch.

Cellulose acetate membrane electrophoresis was first reported by Kohn (1957 and 1958). He refined the method, and developed it on a microscale in 1959. It is applicable to a wide variety of proteins and other molecules, and has several advantages. Separations can usually be achieved much more rapidly on cellulose acetate membranes than on other common support media. Heating is usually not a problem, therefore, and the membranes can be rendered transparent and subjected to densitometric tracing for quantitation of the separated proteins. The manipulations involved are generally simple compared to other support media, so that for routine work cellulose acetate electrophoresis is very convenient. Many commercial cellulose acetate membranes are available, and the technique has found wide application in clinical biochemistry, and to a lesser extent in forensic biochemistry. Cellulose acetate may be used as a support for immunoelectrophoresis and immunodiffusion as well. Detailed descriptions of electrophoretic applications on cellulose acetate have been given by Chin (1970) and by Kohn (1968).

2.3.7 Polyacrylamide gel electrophoresis

Polyacrylamide gels are synthetic gel polymers prepared prior to use in electrophoresis. They may be used for disc electrophoresis, which is carried out in cylindrical tubes, or in gel slabs, much like starch.

2.3.7.1 Polyacrylamide disc gel electrophoresis Disc gel electrophoresis was first devised by Ornstein (1964) and Davis (1964). Ornstein (1964) noted that preliminary results with the method had been reported at meetings as early as 1959. The name derives from the dependence of the technique on discontinuities in the electrophoretic matrix, and from the fact that the separated zones of ions have a discoid shape in the standard procedure. The technique is applicable to the separation of a wide variety of macromolecules of biochemical interest, including proteins. It has not as yet found wide applicability in medico-legal investigations.

Polyacrylamide combines to a great extent all the desirable properties of an electrophoretic medium. The gel is relatively easy to prepare over a range of concentrations. Concentration of the gel is inversely related to pore size so that molecular sieving effects can be controlled. The gels are stable, have good mechanical properties, and are inert and transparent. With disc gel electrophoresis, running times are generally quite short.

Polyacrylamide gels are prepared from acrylamide and the cross linking agent *N,N'*-methylene-bis-acrylamide (sometimes called "Bis"). The main factors determining pore structure are the w/v concentration of acrylamide plus

Bis, and the ratio of Bis to acrylamide concentration. Usually, only the former is varied. Gels can be made from about 3% to about 30%, but the usual gel is in the range of 5 to 10 percent. Free radicals are required for polymerization to take place, and several different ways of providing for their presence have been used in practice. Chemical polymerization is brought about by the addition of ammonium persulfate and tetramethylethylenediamine (TEMED). Ammonium persulfate is a catalyst while the TEMED acts as an initiator. β -dimethylaminopropionitrile (DMAPN) may be substituted for TEMED. A small amount of oxygen is required for initiation, though the continued presence of oxygen inhibits the reaction. Polymerization rate is directly proportional to TEMED concentration. Polymerization may also be brought about photochemically by the addition of riboflavin, and exposure of the solution to UV light. A small amount of oxygen must be present for initiation of photochemical polymerization as well, but as in the case of chemical polymerization, its continued presence is inhibitory. Riboflavin is effective at low concentrations.

The original system consisted of a 7% gel prepared in a small cylindrical glass tube. This gel occupied much, but not all of the volume of the tube, and is called the "separation" or "analytical" gel. Above this gel is prepared a "spacer" or "stacking" gel of much larger pore size (about 3% gel), and about 3 mm in depth. The analytical gel was chemically polymerized, while the stacking gel was polymerized by photochemical means. The sample is then applied above the spacer gel. In the original experiments, the sample was made up in large pore gel medium, and polymerized into place ("sample gel"), but it may be layered on in solution with equally satisfactory results. If it is applied as a solution, sucrose or some other substance is used to make the solution dense, so that the material does not escape and mix with the upper buffer solution. The ions in the buffer systems are chosen according to their mobilities. Kohlrausch showed many years before that in two solutions, one layered above the other, the upper solution containing ions of lower mobility than those of the lower solution, a sharp boundary forms at the interface between the two ions upon passage of current. The boundary is maintained as the ions move at the same rate in the column. The theory indicates that at the pH values selected, proteins migrate with mobilities intermediate between glycinate in the upper buffer compartment and Cl^- in the gel buffer. In the spacer gel, the proteins "stack," i.e. each protein forms a discrete disc, and the separate discs are stacked with the glycinate ion running behind the slowest moving protein. The mobility of the proteins decreases as they enter the smaller pore analytical gel, and the glycinate ion overtakes them to form a sharp boundary with the Cl^- ion. The proteins continue to migrate as a series of thin discs. The use of a tris-chloride buffer for the gel and a glycine upper electrode vessel buffer causes a change in pH during the run as well. The analytical gel buffer is transformed into a tris-glycine buffer having a higher pH than that of the electrode vessel buffer. As a consequence of the

higher pH, the glycinate ion increases its mobility as it enters the analytical gel. More generally, the requirements for satisfactory separation as developed by Ornstein and Davis, were that the leading ion (in the analytical gel buffer) have the highest mobility in the system, that it be an ion of a strong acid, and thus unaffected by pH, that the trailing ion which overtakes all the proteins must be of a weak acid so that its mobility will increase as it passes into the higher pH analytical gel. Further, the buffer counter ions have to be capable of buffering both the trailing and leading ions within the range of pH of the running gel. It was said too that the "stacking" gel was required to allow stacking of the protein discs before migration into the analytical gel, and that a sample gel was needed to avoid diffusion. It is clear from much experimental work, however, that the spacer and sample gels are not required, and many workers dispense with them.

Polyacrylamide disc gel electrophoresis gives excellent separations of many proteins, and only a small amount of sample (μg quantities) is required. Further information on the details and applications of the procedure may be found in Ornstein (1964), Davis (1964), Wieme (1975), Tombs and Akroyd (1967) and Smith (1968).

2.3.7.2 Polyacrylamide flat gel electrophoresis. Polyacrylamide gels can be prepared in flat slab form, in a way very similar to starch gels. This technique was first described by Raymond and Weintraub (1959). Their paper was also the first in which polyacrylamide was proposed as a supporting medium for zone electrophoresis. Except for the discoid shapes of the zones in disc electrophoresis, many of the same considerations apply to slab polyacrylamide electrophoresis as do to disc electrophoresis. Very often, the buffer systems used for flat slab applications are continuous, however, and the ionic fluxes may be different in the gel depending upon this parameter. The gels may be prepared for either horizontal or vertical electrophoresis. One of the advantages of the flat slab technique is that it allows comparison of two different samples on the same gel side by side. The technique is discussed in some detail in Smith (1968), and by Tombs and Akroyd (1967). Parkin (1971) described the use of a horizontal slab polyacrylamide gel with a starch insert. Samples were applied to the starch gel, and then migrated electrophoretically into the acrylamide gel.

2.4 Immuno-electrophoresis

2.4.1 Simple immuno-electrophoresis

Immuno-electrophoresis combines the separation powers of electrophoresis with the specific and sensitive detecting powers of antibodies to the separated proteins by a precipitin reaction. The method was devised by Grabar and Williams in 1953. Its discriminatory capability depends both on the electrophoretic separation achieved and the specificity of the antiserum employed for detection.

In simple, qualitative immuno-electrophoresis, the sample is inserted into a gel and subjected to electrophoresis. Agar gels are often used, although the technique can be carried

out on other supporting media as well. A trough is then cut in the gel a short distance away from the line of electrophoretic migration and parallel to it, and is filled with antiserum. Because diffusion has occurred during the time required for electrophoresis, the separated antigenic proteins will occupy larger areas than was originally occupied by the applied sample. As a result, precipitin arcs form between the trough of antiserum and the line of electrophoretic migration. The method has been used extensively for the study of normal and pathological serum and of other body fluids. Techniques and interpretation of the arc structure are discussed in detail by Ouchterlony (1968), Grabar and Burtin (1964), Cawley (1969) and Arquembourg (1975). A review of immuno-chemical methods used in clinical chemistry, including immunodiffusion and immuno-electrophoresis, is given by Grant and Butt (1970).

2.4.2 Some variations of immuno-electrophoresis

A number of variations of immuno-electrophoretic technique have been proposed, and various authors have applied their own terminology to the methods. Although it is generally quite clear from the descriptions what technique is being used, different authors may use similar terms to describe rather different techniques. In simple immuno-electrophoresis, the antigens are separated electrophoretically, and then detected in a second step by immunodiffusion.

Lang, in 1955, described a technique in which antigen and antibody are applied to the same support medium on parallel lines, the antigen being applied behind the antibody because of its greater mobility. During electrophoresis, the antigen overtakes the antibody and gives a precipitin line. This technique was called "überwanderungselektrophorese" (Lang, 1955; Haan and Lang, 1957). Quantitative results could be obtained by the use of radioactively labelled antigen.

In 1959, Bussard proposed a technique in which both antigen and antibody are placed in wells in an agar gel, the former being placed cathodically, the latter, anodically. Both antigen and antibody have a net anodic electrophoretic mobility at the pH used, but the antibodies show a net cathodic mobility because of electroendosmosis, resulting in the formation of precipitin bands between the antigen and antibody wells. The technique was called "electrosyneresis" by Bussard, but the term is not widely used in the literature. Culliford applied the technique to the immunological determination of species of origin (see Section 16.1.2). More often, the technique is called "cross over electrophoresis". Grunbaum (1972) applied the method to the determination of several serum proteins in bloodstains. The term "cross over electrophoresis" has a more general meaning, though. Any procedure in which two different materials are subjected to electrophoresis in such a way that their paths of migration intersect would fall under the general heading of "cross electrophoresis," according to Nakamura (1966) who has written a definitive reference work on the subject. Cross electrophoresis has been applied to a number of different types of materials on paper and on other types of supports.

Antigen-antibody cross electrophoresis is included in Nakamura's work, although Bussard's technique is not specifically mentioned.

In 1969, Alper and Johnson reported an immunoelectrophoretic technique in which the separated proteins were detected in agar or starch gels by overlaying the gels with antisera after electrophoresis, and allowing the precipitin reaction to proceed. The excess protein could then be washed out in salt solutions, and the antigen-antibody complexes stained with protein stain. They referred to this technique as "immunofixation electrophoresis". Wilson (1964) described a very similar technique, and called it "direct immunoelectrophoresis".

2.4.3. Quantitative immunoelectrophoresis

A number of techniques have been devised for quantitative immunoelectrophoresis. The best single reference to all of these is probably Axelsen *et al.* (1973). Some of the methods have been applied to medico-legal problems while others have not. Emphasis will be placed on the former in this section. All the techniques involve the electrophoresis of antigens in gels containing antibodies to them, under conditions where the immunoglobulins do not migrate, or do so only slightly, in comparison to the antigens. Precipitates form in the systems, and the area delimited by the precipitate is proportional to the antigen: antibody ratio. If either component is held at constant concentration, quantitation of the other is possible.

2.4.3.1 Rocket electrophoresis. The simplest technique involves the electrophoresis of antigens in antibody-containing gels. It was first described by Ressler in 1960. He applied the samples in linear slots. Laurell (1966) modified the procedure somewhat by applying the samples in very small wells in μl quantities. Electrophoresis into antibody-containing gels then gives rocket-shaped precipitin lines, and for this reason the procedure is sometimes called "rocket electrophoresis". Independently, Merrill *et al.* (1967) described the same technique for quantitating immunoglobulins in body fluids. They called it "electroimmunodiffusion", or EID. In 1972, Laurell reviewed the procedure and its technical details. He pointed out that one of the points about the technique whereby it differed from conventional immunoelectrophoresis and immunodiffusion was that diffusion was minimized by the electrophoresis. He did not, therefore, regard the term "electroimmunodiffusion" as appropriate, and called it "electroimmuno assay". A detailed discussion of the practical aspects of the procedure has been given by Weeke (1973a), and Driscoll (1973) discussed the principles underlying rocket electrophoresis.

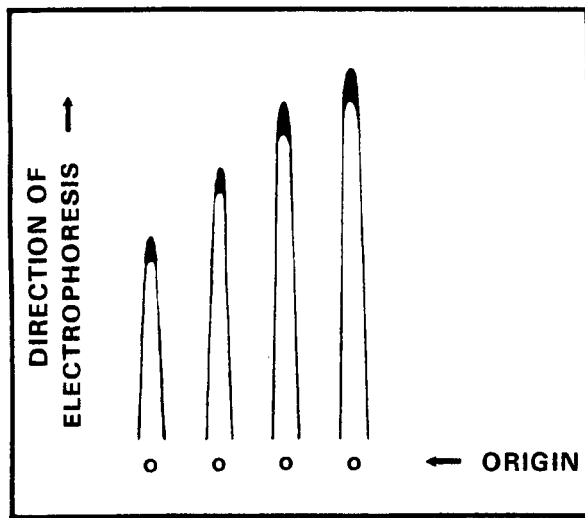
The precipitin line (see Fig. 2.2a) represents the antigen antibody equivalence point (see section 1.3.4.2). Antibody is in excess in the agarose gel, ahead of the migrating antigen. As antigen migrates, equivalence is achieved and precipitation occurs. The precipitin line blocks further migration of antigen into the gel, so that antigen accumulates within the

confines of the precipitin line. As the antigen concentration builds up behind the precipitin line, the precipitate is dissolved, but will be re-formed a little further along the path of antigen migration, where there is, again, equivalence. This process continues, and the precipitin peak, or rocket, is elongated until excess antigen is exhausted and the peak size stabilizes. Peak height thus bears a linear relationship to the amount of antigen originally present, at constant antibody concentration in the gel. This relationship is summarized graphically in Fig. 2.2b. Rocket electrophoresis has been applied to the immunochemical quantitation of acid phosphatase in attempting to differentiate seminal and vaginal acid phosphatases in samples from sexual assault cases (see section 10.3.2).

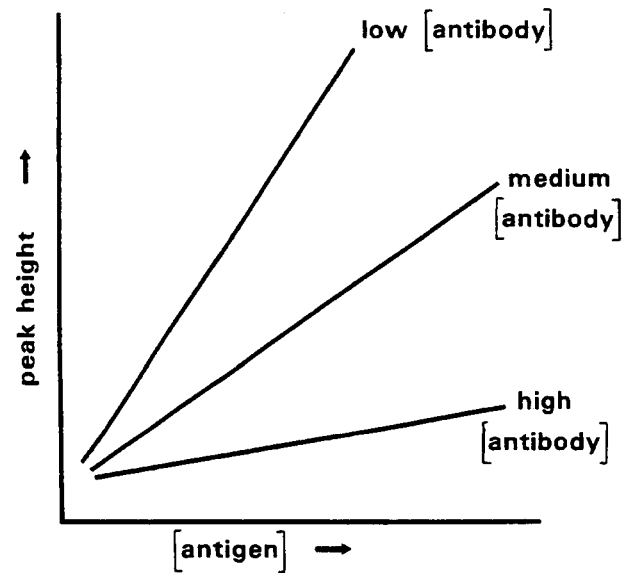
2.4.3.2 Crossed immunoelectrophoresis. In 1965, Laurell described a modified immunoelectrophoretic method in which antigens were first separated electrophoretically, and then subjected to a second electrophoresis, at right angles to the direction of the first, and into an antibody-containing gel. This technique, he called "antigen-antibody crossed electrophoresis". A slightly modified technique was reported by Clarke and Freeman (1968). The type of pattern obtained when this technique is applied to serum proteins (or other complex protein mixtures) is shown in Fig. 2.3. Correspondingly less complex patterns are obtained with less complex mixtures. The principles underlying the relationship between peak area and antigen concentration are essentially the same as those underlying the relationship between peak height and antigen concentration in rocket electrophoresis (section 2.4.3.1). A number of different methods have been employed for the determination of peak area, and these are discussed by Weeke (1973b). Areas under the peaks are compared to those obtained with a reference antigen using the same reference antiserum under the same conditions. The procedure can be carried out on cellulose acetate membranes as well as on agarose gels (Miller and Mutzelberg, 1973).

Ganrot (1973) reviewed the procedure, and suggested that it be called "crossed immunoelectrophoresis", to indicate that it had developed from conventional immunoelectrophoresis, and that electrophoresis was employed in two dimensions. Sweet *et al.* (1973) used the method to examine serologically different proteins in a microorganism, and referred to it as "crossed electroimmunodiffusion", or CEID.

Whitehead *et al.* (1970) applied crossed immunoelectrophoresis to the study of serum proteins in bloodstains, and suggested that the technique might have potential in their discrimination. Saint-Paul *et al.* (1971) also suggested that medico-legal applications of the method might be devised, such as monitoring differential putrefactive degradation changes in bloodstains. Sweet and Elvins (1976a, 1976b) could detect pattern differences in bloodstains from 10 individuals as well as differences between the males and the females. They suggested that the technique could be useful in the individualization of bloodstains. These medico-legal applications will be discussed further in a subsequent section.



(a)



(b)

Figure 2.2 Rocket Electrophoresis

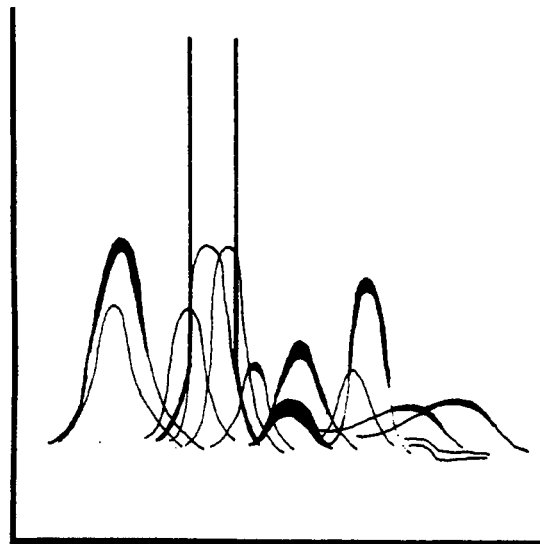


Figure 2.3 Schematic Representation of Pattern of Normal Serum Examined by Crossed Immunoelectrophoresis

2.4.3.3 Other methods of quantitative immunoelectrophoresis. A number of other quantitative immunoelectrophoretic techniques have been devised, as well as further variations of the methods discussed above. Details concerning these may be found in Axelsen *et al.* (1973). They have not thus far been applied directly to medico-legal investigations, but are used in immunologic studies. Axelsen and Bock (1972 and 1973) have reviewed and discussed quantitative immunoelectrophoretic techniques, particularly as they may be applied to the determination of antigen identity or partial identity.

2.5 Isoelectric Focusing and Isotachopheresis

2.5.1 Isoelectric focusing

Isoelectric focusing is not a new technique, but various technical problems prevented its becoming a widely employed analytical and preparative separation method until relatively recently. Molecules which carry both acidic and basic ionizable groups are called ampholytes. Amino acids and proteins are ampholytes, as are many other molecules. All ampholytes have an isoelectric point, or pI, which is the pH at which the molecule has no net charge in solution. In electrophoresis, a constant pH is ordinarily maintained with a buffer, and the protein molecules migrate in the electric field according to their net charge.

If a variety of ampholytes with differing pI is dissolved and subjected to current flow, a pH gradient becomes established. The lowest pH will be near the anode and the highest near the cathode. The gradient forms in this way because the ampholyte of lowest pI will be anionic at all pH greater than its pI, and will migrate toward the anode under the influence of the current. It will collect in a narrow zone in its isoelectric condition and, due to a buffering capacity, will impart to the nearby solution a pH corresponding to its pI. The next most acidic ampholyte will behave similarly, forming another zone slightly cathodic to that of the most acidic component. It does not pass the zone occupied by the most acidic component for, if it did, its pI would be surpassed and it would acquire opposite charge. This process continues until a smooth pH gradient exists between the electrodes. The nature of the pH gradient is determined by the number of ampholytes in the mixture, their relative amounts, buffering capacities and isoelectric points. If large MW ampholytes, such as proteins, are applied to such a system, they will migrate under the influence of the current, and focus in narrow zones corresponding to their isoelectric points. The focusing is brought about by the electric field, and the technique is therefore usually called "isoelectric focusing".

There were a number of experiments carried out over the years on the isoelectric fractionation of ampholytes, including proteins. The earlier experiments are reviewed and reviewed by Svensson (1948), Haglund (1971) and Rilke (1973). Until the early 1960's, the major problem was in obtaining stable, reproducible pH gradients in the presence of the current flow. Svensson (1961, 1962a, 1962b, 1967)

developed the theoretical and practical foundations for the development of electrofocusing methods. The properties of ampholytes required for stable, natural pH gradients were derived from theoretical considerations. Peptides were first used as carrier ampholytes, and allowed the theoretical arguments to be experimentally confirmed. Sucrose density gradients were also used in electrofocusing experiments to minimize convection currents. There are obvious disadvantages to using peptides as carrier ampholytes if one wishes to separate proteins. Vesterberg and Svensson (1966) and Vesterberg (1967) succeeded in synthesizing a series of aliphatic aminocarboxylic acids which had all the desired properties of carrier ampholytes. These are now commercially available as "ampholines". Properties of the ampholine chemicals and their applicability to isoelectric focusing are discussed by Vesterberg (1973) and by Haglund (1975).

Isoelectric focusing gives excellent resolution of proteins, and molecules with differences in pI of as little as 0.02 pH units can be separated. The method has become fairly widely applied in protein chemistry in recent years, and many variations have been developed. Electrofocusing can be carried out, for example, in polyacrylamide gels (Righetti and Drysdale, 1971; Wellner and Hayes, 1973; Vesterberg, 1975). Among other advantages, such procedures minimize convection and help stabilize the pH gradient. Detailed discussion of isoelectric focusing and its applications may be found in the specialized references (Arbuthnott and Beeley, 1975; Catsimpoalas, 1973; Haglund, 1971).

2.5.2 Isotachopheresis

Isotachopheresis is an electrophoretic technique for separating ions, and is related in its theoretical aspects to disc electrophoresis (section 2.3.7.1). In isotachopheresis, all ions of the same sign having a common counterion move at the same speed at equilibrium. They are separated into zones based on their mobilities. A leading ion, with the same sign as those being separated, and with the highest mobility in the system, must be present, as must a trailing ion which has the lowest mobility. In order to achieve separations of proteins, "spacer ions" are used, and the carrier ampholytes used for isoelectric focusing have been employed for this purpose.

The theory and some applications of isotachopheresis may be found in Martin and Everaerts (1970), Everaerts and Routs (1971), Beekers and Everaerts (1972), Everaerts *et al.* (1973) and Routs (1973). Protein separations by isotachopheresis using ampholyte spacers is discussed by Griffith *et al.* (1973) and reviewed by Catsimpoalas (1973). Grunbaum and Hjalmarsson (1976) employed isotachopheresis to examine the protein profiles in aqueous extracts of bloodstains from four different persons. 24 hour extraction times did not alter the pattern in the same individual as compared with brief extractions. The separated proteins were detected by their UV absorption. Different patterns were seen in different individuals, and it was suggested that the procedure might have medico-legal value if future studies confirmed the observed trends.

REFERENCES FOR UNIT I

- Abraham, G. E. 1974. Radioimmunoassay of steroids in biological materials. *Acta Endocrinol.* **75**, suppl. no. 183
- Akaishi, S. 1965. Studies on the group specific double combination method. *Jpn. J. Leg. Med.* **19**: 177-187
- Alper, C. A. and A. M. Johnson. 1969. Immunofixation electrophoresis: a technique for the study of protein polymorphism. *Vox Sang.* **17**: 445-452.
- Araki, C. 1937. Chemical studies of agar-agar. III. On the acetylation of agarous substances of *Galidium Amansii, Lamx*; IV. On the methylation of agarous substances of *Galidium Amansii, Lamx*. *J. Chem. Soc. Japan* **58**: 1338-1350 and 1351-1359
- Araki, C. 1956. Structure of the agarous constituent of agar-agar. *Bull. Chem. Soc. Japan* **29**: 543-544
- Araki, C. and K. Arai. 1956. Studies on the chemical constitution of agar-agar. XVIII. Isolation of a new crystalline disaccharide by enzymatic hydrolysis of agar-agar. *Bull. Chem. Soc. Japan* **29**: 339-345
- Arbesman, C. E. and R. E. Reisman. 1973. Immediate Hypersensitivity, in: N. R. Rose, F. Milgrom and C. J. van Oss (eds.) *Principles of Immunology*, 154-170, Macmillan Publishing Co., New York
- Arbuthnot, J. P. and J. A. Beeley (eds.) 1975. *Isoelectric Focusing*, Butterworths, London
- Arquembourg, P. C. 1975. *Immuno-electrophoresis, Theory, Methods Identifications and Interpretation*, 2nd ed., S. Karger, Basel, München, Paris, etc.
- Asofski, R. and others. 1969. An extension of the nomenclature for immunoglobulins. *Bull. Wld. Hlth. Org.* **41**: 975-977
- Avery, O. T., C. M. MacLeod and M. McCarty. 1944. Studies on the chemical nature of the substance inducing transformation of pneumococcal types. Induction of transformation by a desoxyribonucleic acid fraction isolated from pneumococcus type III. *J. Exp. Med.* **79**: 137-157
- Axelsen, N. H. and E. Bock. 1972. Identification and quantitation of antigens and antibodies by means of immunoelectrophoresis. A survey of methods. *J. Immunol. Meth.* **1**: 109-121
- Axelsen, N. H. and E. Bock. 1973. Further studies on the reaction of partial identity in quantitative immunoelectrophoretic patterns. *J. Immunol. Meth.* **2**: 393-401
- Axelsen, N. H., J. Kroll and B. Weeke (eds.) 1973. A Manual of Quantitative Immunoelectrophoresis, *Scand. J. Immunol.* **2**, suppl. 1, Universitetsforlaget, Oslo, Bergen and Tromsø
- Azen, E. A., R. A. Nazhat and O. Smithies. 1966. Acid buffer systems for urea starch-gel electrophoresis. *J. Lab. Clin. Med.* **67**: 650-659
- Barr, M. L. 1957. Cytologic tests of chromosomal sex. *Progr. Gynecol.* **3**: 131-141
- Barr, M. L. 1960. Sexual dimorphism in interphase nuclei. *Am. J. Hum. Genet.* **12**: 118-127
- Barr, M. L. and E. G. Bertram. 1949. A morphological distinction between neurones of the male and female, and the behaviour of the nucleolar satellite during accelerated nucleoprotein synthesis. *Nature* **163**: 676-677
- Barrett, J. T. 1974. *Textbook of Immunology*, 2nd ed., C. V. Mosby Co., St. Louis
- Bateson, W. 1909. *Mendel's Principles of Heredity*, Cambridge Univ. Press, Cambridge
- Beadle, G. W. and E. L. Tatum. 1941. Genetic control of biochemical reactions in *Neurospora*. *Proc. Nat. Acad. Sci. U.S.A.* **27**: 499-506
- Beckers, J. L. and F. M. Everaerts. 1972. Isotachopheresis. The qualitative separation of cation mixtures. *J. Chromatog.* **68**: 207-230
- Bennich, H. H. and others. 1968. Immunoglobulin E, a new class of human immunoglobulin. *Bull. Wld. Hlth. Org.* **38**: 151-152
- Berne, B. H. 1974. Differing methodology and equations used in quantitating immunoglobulins by radial immunodiffusion—a comparative evaluation of reported and commercial techniques. *Clin. Chem.* **20**: 61-69
- Beutler, E. 1969. G-6-PD activity of individual erythrocytes and X-chromosomal inactivation, in: J. J. Yunis (ed.) *Biochemical Methods in Red Cell Genetics*, 95-113, Academic Press, New York
- Bohinski, R. C. 1973. *Modern Concepts in Biochemistry*, Allyn and Bacon, Inc., Boston
- Bordet, J. 1909. *Studies in Immunity*, papers collected and translated into English by F. P. Gay, John Wiley & Sons, New York and Chapman & Hall, Ltd., London
- Bordet, J. and F. P. Gay. 1906. Sur les relations des sensibilisatrices avec l'alexine. *Ann. Inst. Pasteur, Paris* **20**: 467-498 and see Bordet (1909).
- Boyd, W. C. 1941. Influence of character of antibody upon velocity of flocculation. *J. Exp. Med.* **74**: 369-386
- Boyd, W. C. 1966. *Fundamentals of Immunology*, 4th ed., Interscience Publishers, New York, London & Sidney
- Boyer, S. H. IV (ed.). 1963. *Papers on Human Genetics*, Prentice-Hall, Inc., Englewood Cliffs, N.J.
- Bradford, M. M. 1976. A rapid and sensitive method for the quantitation of protein utilizing the principle of protein-dye binding. *Anal. Biochem.* **72**: 248-254
- Brinkmann, B., E. Kooops and H. H. Hoppe. 1971. Disagreements between observed and expected data in erythrocyte acid phosphatase polymorphism. Reference laboratories for enzyme polymorphisms. *Z. Rechtsmed.* **69**: 191-196
- Buchner, H. 1899. Natürliche Schutzeinrichtungen des Organismus und deren Beeinflussung zum Zweck der Abwehr von Infektionsprocessen. *Muench. Med. Wochenschr.* **46** (39): 1261-1265
- Buchner, H. 1900. Zur Kenntnis der Alexins, sowie der spezifisch-bactericiden und spezifisch-haemolytischen Wirkungen. *Muench. Med. Wochenschr.* **47** (9): 277-283
- Burdette, W. J. (ed.). 1962. *Methodology in Human Genetics*, Holden-Day, Inc., San Francisco
- Bussard, A. 1959. Description d'une technique combinant simultanément l'électrophorèse et la précipitation immunologique dans un gel: l'électrosynérèse. *Biochim. Biophys. Acta* **34**: 258-260
- Carpenter, P. L. 1975. *Immunology and Serology*, 3rd ed., W. B. Saunders Co., Philadelphia, London and Toronto
- Catsimpoalas, N. 1973. Isoelectric focusing and isotachopheresis of proteins. *Sep. Sci.* **8**: 71-121
- Catsimpoalas, N. (ed.). 1973. *Isoelectric Focusing and Isotachopheresis*. *Ann. N.Y. Acad. Sci.* **209**: 1-529
- Carlson, E. A. 1966. *The Gene: A Critical History*, W. B. Saunders & Co., Philadelphia and London
- Cavalli-Sforza, L. L. and W. F. Bodmer. 1971. *The Genetics of Human Populations*, W. H. Freeman & Co., San Francisco
- Cawley, L. P. 1969. *Electrophoresis and Immuno-electrophoresis*, Little, Brown & Co., Boston
- Cepellini, R. and many others. 1964. Nomenclature for human immunoglobulins. *Bull. Wld. Hlth. Org.* **30**: 447-450
- Chin, H. P. 1970. *Cellulose Acetate Electrophoresis, Techniques and Applications*, Ann Arbor-Humphrey Science Publishers, Ann Arbor and London
- Clarke, H. G. M. and T. Freeman. 1968. Quantitative immunoelectrophoresis of human serum proteins. *Clin. Sci.* **35**: 403-413
- Cohen, S. and R. T. McCluskey. 1973. Delayed Hypersensitivity, in: N. R. Rose, F. Milgrom and C. J. van Oss (eds.) *Principles of Immunology*, 189-204, Macmillan Publishing Co., New York
- Conn, E. E. and P. K. Stumpf. 1976. *Outlines of Biochemistry*, 4th ed., John Wiley & Sons, New York, London, etc.
- Conden, R., A. H. Gordon and A. J. P. Martin. 1944. Partition chromatography of amino acids. *Biochem. J.* **38**: Proc. Biochem. Soc., ix (Abstr.)

- Coombs, R. R. A. and B. Dodd. 1961. Possible application of the principle of mixed agglutination in the identification of blood stains. *Med. Sci. Law* 1: 359-377
- Coombs, R. R. A., A. E. Mourant and R. R. Race. 1945. A new test for the detection of weak and "incomplete" Rh agglutinins. *Br. J. Exp. Pathol.* 26: 255-266
- Cremer, H-D. and A. Tiselius. 1950. Elektrophorese von Eiweiss in Filterpapier. *Biochem. Z.* 320: 273-283
- Crow, J. F. and M. Kimura. 1970. *An Introduction to Population Genetics Theory*, Harper & Row, New York, Evanston and London
- Crowle, A. J. 1973. *Immunodiffusion*, 2nd ed., Academic Press, Academic Crowle, New York & London
- Dahlberg, G. 1948. *Mathematical Models for Population Genetics*, S. Karger, Basel and Interscience Publishers, New York and London
- Davidson, R. G. 1968. The Lyon hypothesis. *Ann. N.Y. Acad. Sci.* 151: 157-158
- Davis, B. J. 1964. Disc electrophoresis. II. Method and application to human serum proteins. *Ann. N.Y. Acad. Sci.* 121: 404-427
- Dean, H. R. and R. A. Webb. 1926. The influence of optimal proportions of antigen and antibody in the serum precipitation reaction. *J. Pathol. Bacteriol.* 29: 473-492
- Determann, H. and J. E. Brewer. 1975. Gel chromatography, in: E. Heftmann (ed.) *Chromatography, A Handbook of Chromatographic and Electrophoretic Methods*, 3rd ed., 362-392, Van Nostrand Reinhold Co., New York, Cincinnati, etc.
- Deutsch, H. F., R. A. Alberty, L. J. Gosting and J. W. Williams. 1947. Biophysical studies of blood plasma proteins. IV. Immunological properties of γ_1 -globulin from the plasma of normal humans. *J. Immunol.* 56: 183-194
- Deys, B. F., K. H. Grzeschick, A. Grzeschick, E. R. Jaffe and M. Siniscalco. 1972. Human phosphoglycerate kinase and inactivation of the X-chromosome. *Science* 175: 1002-1003
- Diehl, J. E. and M. F. Mallette. 1964. Nature of the Forssman hapten from sheep erythrocytes. *J. Immunol.* 93: 965-971
- Dixon, G. H. and O. Smithies. 1957. Zone electrophoresis of cabbage enzymes in starch gels. *Biochim. Biophys. Acta* 23: 198-199
- Driscoll, M. J. 1973. Specific protein determinations using immunoelectrophoresis. *Ann. Clin. Biochem.* 10: 4-13
- Duckworth, M. and W. Yaphe. 1971a. The structure of agar. Part I. Fractionation of a complex mixture of polysaccharides. *Carbohydr. Res.* 16: 189-197
- Duckworth, M. and W. Yaphe. 1971b. The structure of agar. Part II. The use of a bacterial agarase to elucidate structural features of the charged polysaccharides in agar. *Carbohydr. Res.* 16: 435-445
- Durum, E. L. 1950. A microelectric and microionophoretic technique. *J. Am. Chem. Soc.* 72: 2943-2948
- Edelman, G. M. 1971. Antibody structure and molecular immunology. *Ann. N.Y. Acad. Sci.* 190: 5-25
- Edelman, G. M. 1976. The structure and function of antibodies, in: Immunology, Readings from Scientific American, 39-48, W. H. Freeman & Co., San Francisco
- Ehrlich, P. and J. Morgenroth. 1899a. Zur Theorie der Lysinwirkung. *Berl. Klin. Wochenschr.* 36 (1): 6-9 and see: F. Himmelweit (ed.) *The Collected Papers of Paul Ehrlich*, v. II, 143-149 and 150-155, Pergamon Press, London, New York, Paris, 1957
- Ehrlich, P. and J. Morgenroth. 1899b. Ueber Haemolysine. Zweite Mittheilung. *Berl. Klin. Wochenschr.* 36 (22): 481-486 and see F. Himmelweit (ed.) *The Collected Papers of Paul Ehrlich*, v. II, 156-164 and 165-172, Pergamon Press, London, New York and Paris, 1957
- Ehrlich, P. and J. Morgenroth. 1901. Über Hämolysine. Fünfte Mittheilung. *Berl. Klin. Wochenschr.* 38 (10): 251-257 and see F. Himmelweit (ed.) *The Collected Papers of Paul Ehrlich*, v. II, 234-245 and 246-255, Pergamon Press, London, New York and Paris, 1957
- Emery, A. E. H. 1976. *Methodology in Medical Genetics*, Churchill Livingstone, Edinburgh, London & New York
- Everaerts, F. M., J. L. Beckers and Th. P. E. M. Verheggen. 1973. Some theoretical and practical aspects of isotachophoretic analysis. *Ann. N.Y. Acad. Sci.* 209: 419-444
- Everaerts, F. M. and R. J. Routs. 1971. Calculation and measurement of concentration in isotachophoresis. *J. Chromatogr.* 58: 181-194
- Fahey, J. L. 1970. Classes of blood group antibodies. *Ann. N.Y. Acad. Sci.* 169: 164-167
- Field, C. W. and O. Teague. 1907a. The electrical charge of toxin and antitoxin. *J. Exp. Med.* 9: 86-92
- Field, C. W. and O. Teague. 1907b. On the electrical charge of the native proteins and the agglutinins. *J. Exp. Med.* 9: 222-225
- Fischer, L. 1969. *An Introduction to Gel Chromatography*, North-Holland Publishing Co., Amsterdam and Oxford
- Fisher, R. A. 1951. Standard calculations for evaluating a blood group system. *Heredity* 5: 95-102
- Fisher, R. A. 1970. *Statistical Methods for Research Workers*, 14th ed., Hafner Pub. Co., Darien, CT
- Fölling, A. 1934. Über Ausscheidung von Phenylbrenztraubensäure in den Harn als Stoffwechselanomalie in Verbindung mit Imbezillität. *Hoppe Seyler's Z. Physiol. Chem.* 227: 169-176
- Ford, E. B. 1965. *Genetic Polymorphism*, Faber & Faber, London
- Gally, J. A. 1973. Structure of immunoglobulins, in: M. Sela (ed.) *The Antigens*, vol. I, 161-298, Academic Press Inc., New York and London
- Ganrot, P.O. 1972. Crossed immunoelectrophoresis. *Scand. J. Clin. Lab. Invest.* 29, suppl. 124: 39-47
- Garrod, A. E. 1902. The incidence of alcaptonuria: a study in chemical individuality. *Lancet* 2: 1616-1620
- Garrod, A. E. 1908. Inborn Errors of Metabolism. *Lancet* 2: 1-7 and 73-79
- Garrod, A. E. 1923. *Inborn Errors of Metabolism*, 2nd ed., Henry Frowde and Hodder and Stoughton, London
- Gengou, O. 1902. Sur les sensibilisatrices des sérum actifs contre les substances albuminoïdes. *Ann. Inst. Pasteur, Paris* 16: 734-755 and see Bordet (1909)
- Goldsmith, K. L. G. 1974. The effect of bovine serum albumin on red cell agglutination, in: *Enhancement of Serological Reactions, One Day Symposium* at London Hospital Medical College, November 1974, Biotest-Folex, Ltd., Birmingham
- Gordon, A. H. 1975. *Electrophoresis of Proteins in Polyacrylamide and Starch Gels*, North-Holland Publishing Co., Amsterdam and Oxford
- Gordon, A. H., B. Keil and K. Sebesta. 1949. Electrophoresis of proteins in agar jelly. *Nature* 164: 498-499
- Gornall, A. G., C. J. Bardawill and M. M. David. 1949. Determination of serum proteins by means of the biuret reaction. *J. Biol. Chem.* 177: 751-766
- Grabar, P. and P. Burtin (eds.) 1964. *Immuno-electrophoretic Analysis*, Elsevier Publishing Co., Amsterdam, London and New York, first published as: *Analyse Immunoelectrophoretique*, Masson and Cie, Paris, 1960
- Grabar, P. and C. A. Williams. 1953. Méthode permettant l'étude conjuguée des propriétés électrophorétiques et immunochimiques d'un mélange de protéines. Application au sérum sanguin. *Biochim. Biophys. Acta* 10: 193-194
- Grant, G. H. and W. R. Butt. 1970. Immunochemical methods in clinical chemistry. *Adv. Clin. Chem.* 13: 383-466
- Griffith, A., N. Catsimopoulos and J. Kenney. 1973. Analytical gel isotachophoresis of proteins with carrier ampholyte spacers. *Ann. N.Y. Acad. Sci.* 209: 457-469
- Griffith, F. 1928. The significance of pneumococcal types. *J. Hyg.* 27: 113-159
- Grey, H. M., C. A. Abel and B. Zimmerman. 1971. Structure of IgA proteins. *Ann. N.Y. Acad. Sci.* 190: 37-48
- Grunbaum, B. W. 1972. Recent progress in the individualization of blood and the adaptation of the Hyland cross-over electrophoresis system in the identification of bloodstains. *J. Forensic Sci. Soc.* 12: 421-423
- Grunbaum, B. W. and S. G. Hjalmarsson. 1976. Isotachophoresis of bloodstains. *J. Forensic Sci. Soc.* 16: 325-331
- Gunson, H. H. 1974. The use of enzymes in blood group serology, in: *Enhancement of Serological Reactions, One Day Symposium* at London Hospital Medical College, November, 1974, Biotest-Folex, Ltd., Birmingham

- Haan, J. and N. Lang. 1957. Quantitative Bestimmung der Antigenbindung in Antigen-Antikörper-Komplex mit der Überwanderungselektrophorese. *Klin. Wochenschr.* 35: 1013-1016
- Haglund, H. 1971. Isoelectric focusing in pH gradients—a technique for fractionation and characterization of ampholytes, in: D. Glick (ed.) *Methods of Biochemical Analysis* 19: 1-104, Interscience Publishers, Divn. of John Wiley & Sons, New York, London, etc.
- Haglund, H. 1975. Properties of ampholine, in: J. P. Arbutnot and J. A. Beeley (eds.) *Isoelectric Focusing*, 3-22, Butterworths, London
- Haldane, J. B. S. 1919. The combination of linkage values, and the calculation of distances between the loci of linked factors. *J. Genet.* 8: 299-309
- Hardy, G. H. 1908. Mendelian proportions in mixed populations. *Science* 28 (NS): 49-50 and see J. A. Peters (ed.) *Classic Papers in Genetics*, 60-62, Prentice Hall, Inc., Englewood Cliffs, N.J., 1959
- Henriksen, S. D. 1970. *Immunology*. Universitets Forlaget, Oslo and Williams and Wilkins Co., Baltimore
- Hershey, A. D. and M. Chase. 1952. Independent functions of viral protein and nucleic acid in growth of bacteriophage. *J. Gen. Physiol.* 36: 39-56
- Hill, R. J. 1968. An evaluation of a method of quantitative radial immunodiffusion. *Immunochemistry* 5: 185-202
- Hjerten, S. 1962a. A new method for preparation of agarose for gel electrophoresis. *Biochim. Biophys. Acta* 62: 445-449
- Hjerten, S. 1962b. Chromatographic separation according to size of macromolecules and cell particles on columns of agarose suspensions. *Arch. Biochem. Biophys.* 99: 466-475
- Holley, R. W., J. Appgar, G. A. Everett, J. T. Madison, M. Marquisee, S. H. Merrill, J. R. Penswick and A. Zamir. 1965. Structure of a ribonucleic acid. *Science* 147: 1462-1465
- Hooker, S. B. and W. C. Boyd. 1937. The non-specificity of the flocculative phase of serologic aggregation. *J. Immunol.* 33: 337-354
- Hughes-Jones, N. C. 1974. Factors affecting the enhancement of serological reactions, in: Enhancement of Serological Reactions, One Day Symposium at London Hospital Medical College, November, 1974, Biotest-Folex, Ltd., Birmingham
- Hughes-Jones, N. C. 1975. Red-cell antigens, antibodies and their interaction. *Clin. Haematol.* 4: 29-43
- Humphrey, J. H. and R. G. White. 1970. *Immunology for Students of Medicine*, 3rd ed., Blackwell Scientific Publications, Oxford and Edinburgh
- Huntoon, F. M. 1921. Antibody studies. I. Reversal of the antigen-antibody reaction. *J. Immunol.* 6: 117-122
- Huntoon, F. M. and S. Estris. 1921. Antibody studies. II. The recovery of antibody from sensitized antigens: technic. *J. Immunol.* 6: 123-184
- Huntoon, F. M., P. Masucci and E. Hannum. 1921. Antibody studies. III. Chemical nature of antibodies. *J. Immunol.* 6: 185-200
- Jacquard, A. 1974. *The Genetic Structure of Populations*, vol. 5 in K. Krickeberg, R. C. Lewentin, J. Neyman and M. Schreiber (eds.) *Biostatistics*, Springer Verlag, Berlin, Heidelberg and New York, first published as *Structures Génétiques des Populations*, Masson and Cie, Paris, 1970
- Jaffe, B. M. and H. R. Behrman (eds.) 1974. *Methods of Hormone Radioimmunoassay*, Academic Press, New York and London
- Jerne, N. K. 1951. A study of avidity based on rabbit skin responses to diphtheria toxin-antitoxin mixtures. *Acta Pathol. Microbiol. Scand.*, suppl. 87
- Jones, D. A. 1972. Blood samples: probability of discrimination. *J. Forensic Sci. Soc.* 12: 355-359
- Kabat, E. A. 1970. Heterogeneity and structure of antibody-combining sites. *Ann. N.Y. Acad. Sci.* 169: 43-54
- Kempthorne, O. 1969. *An Introduction to Genetic Statistics*, Iowa State University, Ames
- Kendall, J. 1928. Separations by the ionic migration method. *Science* 67: 163-167
- Kochwa, S., W. D. Terry, J. D. Capra and N. L. Yang. 1971. Structural studies of immunoglobulin E: I. Physicochemical studies of the IgE molecule. *Ann. N.Y. Acad. Sci.* 190: 49-70
- Kohn, J. 1957. A cellulose acetate supporting medium for zone electrophoresis. *Clin. Chim. Acta* 2: 297-303
- Kohn, J. 1958. Membrane filter electrophoresis, in: H. Peeters (ed.) *Protides of the Biological Fluids*, Proc. of 5th Colloq., Bruges, 1957, 120-125, Elsevier Publishing Co., Amsterdam, New York, etc.
- Kohn, J. 1959. Small-scale and micro-membrane filter-electrophoresis and immunoelectrophoresis, in: H. Peeters (ed.) *Protides of the Biological Fluids*, Proc. of 6th Colloq., Bruges, 1958, 74-78, Elsevier Publishing Co., Amsterdam, New York, etc.
- Kohn, J. 1968. Cellulose acetate electrophoresis and immunodiffusion techniques in: I. Smith (ed.) *Chromatographic and Electrophoretic Techniques*. 2nd ed., v. II, 84-146, Interscience Publishers, Divn. of John Wiley and Sons, New York
- Kornberg, A. 1959. Enzymatic synthesis of deoxyribonucleic acid. *Harvey Lectures* 53: 83-112 (1957-1958)
- Kornberg, A., I. R. Lehman and E. S. Sims. 1956. Polydesoxyribonucleotide synthesis by enzymes from *Escherichia coli*. *Fed. Proc., Fed. Am. Soc. Exp. Biol.* 15: 291-292 (Abstr.)
- Kraus, K. A. and G. W. Smith. 1950. Electromigration on filter paper. *J. Am. Chem. Soc.* 72: 4329-4330
- Kunkel, H. G. and others. 1966. Notation for human immunoglobulin subclasses. *Bull. Wld. Hlth. Org.* 35: 953
- Kunkel, H. G. and R. J. Slater. 1952. Zone electrophoresis in a starch supporting medium. *Proc. Soc. Exp. Biol. Med.* 80: 42-44
- Kunkel, H. G. and A. Tiselius. 1951. Electrophoresis of proteins on filter paper. *J. Gen. Physiol.* 35: 89-118
- Kunkel, H. G. and R. Trautman. 1959. Zone electrophoresis in various types of supporting media, in: M. Bier (ed.) *Electrophoresis, Theory Methods and Applications*, 225-262, Academic Press, Inc., New York
- Landsteiner, K. 1962. *The Specificity of Serological Reactions*, rev. ed., Dover Publications, New York
- Lang, N. 1955. Ein Verfahren zum Nachweis von Reaktionen vom Typ der Antigen-Antikörperbindung. *Klin. Wochenschr.* 33: 29-30
- Laurell, C. B. 1965. Antigen-antibody crossed electrophoresis. *Anal. Biochem.* 10: 358-361
- Laurell, C.-B. 1966. Quantitative estimation of proteins by electrophoresis in agarose gel containing antibodies. *Anal. Biochem.* 15: 45-52
- Laurell, C.-B. 1972. Electroimmuno assay. *Scand. J. Clin. Lab. Invest.* 29, suppl. 124: 21-37
- Layne, E. 1957. Spectrophotometric and colorimetric methods for measuring proteins, in: S. P. Colowick and N. O. Kaplan (eds.) *Methods in Enzymology* 3: 447-454, Academic Press, New York
- Lehninger, A. L. 1975. *Biochemistry*, 2nd ed., Worth Publishers, Inc., New York
- Levine, R. P. 1968. *Genetics*, 2nd ed., Holt, Rinehart and Winston, Inc., New York, Chicago, etc.
- Levitan, M. and A. Montagu. 1971. *Textbook of Human Genetics*, Oxford Univ. Press, New York, London, Toronto
- Linder, D. and S. M. Gartler. 1965. Distribution of glucose-6-phosphate dehydrogenase electrophoretic variants in different tissues of heterozygotes. *Am. J. Hum. Genet.* 17: 212-220
- Liu, Y.-S. V., T. L. K. Low, A. Infante and F. W. Putnam. 1976. Complete covalent structure of a human IgA1 immunoglobulin. *Science* 193: 1017-1020
- Longworth, L. G. 1959. Moving boundary electrophoresis—theory, and practice, in: M. Bier (ed.) *Electrophoresis, Theory Methods and Applications*, 91-136 and 137-177, Academic Press, New York
- Lowry, O. H., N. J. Rosebrough, A. L. Farr and R. J. Randall. 1951. Protein measurement with the Folin phenol reagent. *J. Biol. Chem.* 193: 265-275
- Luft, R. and R. S. Yalow (eds.) 1974. Radioimmunoassay: methodology and applications in physiology and in clinical studies (Commemorative issue for Solomon A. Berson). *Horm. Metab. Res., Suppl. Ser. No. 5*
- Lyon, M. F. 1961. Gene action in the X-chromosome of the mouse (*Mus musculus* L.). *Nature* 190: 372-373
- Lyon, M. F. 1962a. Attempts to test the inactive-X theory of dosage compensation in mammals. *Ann. Hum. Genet.* 25: 423 (Abstr.)
- Lyon, M. F. 1962b. Sex chromatin and gene action in the mammalian X-chromosome. *Am. J. Hum. Genet.* 14: 135-148

- Mallette, M. F., C. O. Clagett, A. T. Phillips and R. L. McCarl. 1971. *Introductory Biochemistry*, Williams and Wilkins, Baltimore
- Mancini, G., A. O. Carbonara and J. F. Heremans. 1965. Immunochemical quantitation of antigens by single radial immunodiffusion. *Immunochemistry* 2: 235-254
- Marrack, J. R. 1938. *The Chemistry of Antigens and Antibodies*, Med. Res. Council Spec. Rep. Ser. No. 230, H. M. Stationery Office, London
- Martin, A. J. P. and F. M. Everaerts. 1970. Displacement electrophoresis. *Proc. R. Soc. London Ser. A* 316: 493-514
- Mather, K. 1973. *Genetical Structure of Populations*, Chapman and Hall, London
- Mayer, M. M. 1976. The complement system, in: *Immunology*, Readings from Scientific American, 143-155, W. H. Freeman & Co., San Francisco
- McDonald, J. A. and W. N. Kelley. 1972. Lesch-Nyhan syndrome: absence of the mutant enzyme in erythrocytes of a heterozygote for both normal and mutant hypoxanthine-guanine phosphoribosyl transferase. *Biochem. Genet.* 6: 21-26
- McDonald, H. J., M. C. Urbin and M. B. Williamson. 1950. Measurement of ion migration on paper in an electric field. Transference numbers of nickel and copper sulfates. *Science* 112: 227-229
- McKusick, V. A. 1964. *On the X-Chromosome of Man*, Am. Inst. Biol. Sci., Washington, D.C.
- McKusick, V. A. 1975. *Mendelian Inheritance in Man. Catalogs of Autosomal Dominant, Autosomal Recessive and X-linked Phenotypes*, 4th ed., Johns Hopkins Univ. Press, Baltimore and London
- McKusick, V. A. and F. H. Ruddle. 1977. The status of the gene map of human chromosomes. *Science* 196: 390-405
- Mendel, G. 1865. Versuche über Pflanzen-Hybriden. *Verh. Naturforsch. Verein, Brünn, Abhandl.* 4: 3-47 (appeared in 1866)
- Merrill, D., T. F. Hartley and H. N. Claman. 1967. Electroimmunodiffusion (EID): a simple, rapid method for quantitation of immunoglobulins in dilute biological fluids. *J. Lab. Clin. Med.* 69: 151-159
- Meselson, M. and F. W. Stahl. 1958. The replication of DNA in *Escherichia coli*. *Proc. Nat. Acad. Sci. USA* 44: 671-682
- Mettler, L. E. and T. G. Gregg. 1969. *Population Genetics and Evolution*, Prentice-Hall, Inc., Englewood Cliffs, NJ
- Michl, H. 1975. Techniques of electrophoresis, in: E. Heftmann (ed.) *Chromatography*, 3rd ed., 282-311, Van Nostrand Reinhold Co., New York, Cincinnati, etc.
- Miller, J. N. and I. D. Mutzelberg. 1973. Laurell electrophoresis on cellulose acetate. *J. Chromatogr.* 75: 165-168
- Mollison, P. L. 1972. *Blood Transfusion in Clinical Medicine*, 5th ed., Blackwell Scientific Publications, Oxford, London
- Morton, N. E. 1962. Segregation and Linkage. in: W. J. Burdette (ed.) *Methodology in Human Genetics*, 17-52, Holden-Day, Inc. San Francisco
- Müller-Eberhard, H. J. 1975. Complement. *Ann. Rev. Biochem.* 44: 697-724
- Nakamura, S. 1966. *Cross Electrophoresis, Its Principle and Applications*, Igaku Shoin, Ltd., Tokyo
- Ornstein, L. 1964. Disc electrophoresis—I. Background and theory. *Ann. N.Y. Acad. Sci.* 121: 321-349
- Orten, J. M. and O. W. Neuhaus. 1975. *Human Biochemistry*, 9th ed., C. V. Mosby Co., St. Louis
- Ouchterlony, Ö. 1968. *Handbook of Immunodiffusion and Immunoelectrophoresis*, Ann Arbor Science Publishers, Inc., Ann Arbor
- Parker, C. W. 1976. *Radioimmunoassay of Biologically Active Compounds*, Prentice Hall Inc., Englewood Cliffs, N.J.
- Parkin, B. H. 1971. An improved method for the electrophoresis of enzymes using a polyacrylamide-starch gel. *Biochem. J.* 122: 61P-62P
- Pedersen, K. O. 1945. *Ultracentrifugal Studies on Serum and Serum Fractions*, Almqvist and Wiksells Boktryckeri AB, Uppsala, Sweden
- Peters, J. A. (ed.) 1959. *Classic Papers in Genetics*, Prentice-Hall, Englewood Cliffs, NJ
- Peterson, E. A. 1970. *Cellulosic Ion Exchangers* North-Holland Publishing Co., Amsterdam and Oxford
- Pollack, W., H. J. Hager, R. Reckel, D. A. Toren and H. O. Singher. 1965. A study of the forces involved in the second stage of hemagglutination. *Transfusion (Philadelphia)* 5: 158-183
- Porter, R. R. 1976. The structure of antibodies, in: *Immunology*, Readings from Scientific American, 31-38, W. H. Freeman & Co., San Francisco
- Portier, and Ch. Richet. 1902. De l'action anaphylactique de certains venins. *C. R. Soc. Biol.* 54: 170-172
- Poulik, M. D. 1957. Starch gel electrophoresis in a discontinuous system of buffers. *Nature* 180: 1477-1479
- Ramon, G. 1922. Flocculation dans un mélange neutre de toxine-antitoxine. *C. R. Soc. Biol.* 86: 661-663
- Rawson, A. J. and N. M. Abelson. 1964. Studies on blood group antibodies. VI. The blood group isoantibody activity of γ_{1A} -globulin. *J. Immunol.* 93: 192-198
- Raymond, S. and L. Weintraub. 1959. Acrylamide gel as a supporting medium for zone electrophoresis. *Science* 130: 711
- Reckel, R. P. and J. Harris. 1978. The unique characteristics of covalently polymerized bovine serum albumin solutions when used as antibody detection media. *Transfusion (Phila)* 18: 397-406
- Recommendations (1964) of the International Union of Biochemistry on the Nomenclature and Classification of Enzymes, together with their Units and the Symbols of Enzyme Kinetics. Has title: *Enzyme Nomenclature*, Elsevier Publishing Co., Amsterdam, New York and London, 1965
- Rees, D. A. 1972. Polysaccharide gels. A molecular view. *Chem. Ind. (London)* no. 16: 630-636
- Reichlin, M. 1973. Complement fixation, in: N. R. Rose, F. Milgrom and C. J. van Oss (eds.) *Principles of Immunology*, 83-92, Macmillan Publishing Co., New York
- Ressler, N. 1960. Electrophoresis of serum protein antigens in an antibody-containing buffer. *Clin. Chim. Acta* 5: 359-365
- Reunala, T., A. I. Koskimies, F. Björkstén, J. Jänne and A. Lassus. 1977. Immunoglobulin E-mediated severe allergy to human seminal plasma. *Fertil. Steril.* 28: 832-835
- Righetti, P. and J. W. Drysdale. 1971. Isoelectric focusing in polyacrylamide gels. *Biochim. Biophys. Acta* 236: 17-28
- †Rilbe, H. 1973. Historical and theoretical aspects of isoelectric focusing. *Ann. N.Y. Acad. Sci.* 209: 11-22
- Robinson, H. W. and C. G. Hogden. 1940. The biuret reaction in the determination of serum proteins. I. A study of the conditions necessary for the production of a stable color which bears a quantitative relationship to the protein concentration. II. Measurements made by a Duboscq colorimeter compared with values obtained by the Kjeldahl procedure. *J. Biol. Chem.* 135: 707-725 and 727-731
- Routs, R. J. 1973. The choice of electrolyte conditions for isotachophoretic separations. *Ann. N.Y. Acad. Sci.* 209: 445-456
- Saint-Paul, M., P. Rebeyrotte, L. Dérobert, J. Peillet and J. P. Labbé. 1971. Intéret de l'immuno-électrophorèse bidimensionnelle en médecine légale. *Med. Leg. Dommage Corpor.* 4: 126-129
- Schoch, T. J. 1961. Starches and amylases. *Proc. Am. Soc. Brewing Chemists:* 83-92
- Sela, M. 1971. Effect of antigenic structure on antibody biosynthesis. *Ann. N.Y. Acad. Sci.* 190: 181-202
- Selvin, S. 1970. Twin zygosity diagnosis by blood group antigens. *Hum. Hered.* 20: 540-548
- Smith, I. 1968. Acrylamide gel disc electrophoresis: techniques of disc electrophoresis, in: I. Smith (ed.) *Chromatographic and Electrophoretic Techniques*, 2nd Ed., v. II, 365-389, Interscience Publishers, Divn. of John Wiley & Sons, New York
- Smith, I. (ed.) 1968. *Chromatographic and Electrophoretic Techniques*, 2nd ed., v. II Zone Electrophoresis, Interscience Publishers, Divn. of John Wiley & Sons, New York
- Smithies, O. 1955a. Zone electrophoresis in starch gels: group variations in the serum proteins of normal human adults. *Biochem. J.* 61: 629-641
- Smithies, O. 1955b. Grouped variations in the occurrence of new protein components in normal human serum. *Nature* 175: 307-308

† Known as H. Svensson until 1968

- Smithies, O. 1959a. An improved procedure for starch gel electrophoresis: further variations in the serum proteins of normal individuals. *Biochem. J.* 71: 585-587
- Smithies, O. 1959b. Zone electrophoresis in starch gels and its application to studies of serum proteins. *Adv. Protein Chem.* 14: 65-113
- Smithies, O. and M. D. Poulik, 1956. Two dimensional electrophoresis of serum proteins. *Nature* 177: 1033
- Stern, C. 1973. *Principles of Human Genetics*, 3rd ed. W. H. Freeman and Co., San Francisco
- Subcommittee for Human Immunoglobulins of the IUIS Nomenclature Committee. 1972. Recommendations for the nomenclature of human immunoglobulins. *J. Immunol.* 108: 1733-1734
- Sweet, G. H. and J. W. Elvins. 1976a. Human bloodstains: individualization by crossed electroimmunodiffusion. *Science* 192: 1012-1014
- Sweet, G. H. and J. W. Elvins. 1976b. Studies by crossed electroimmunodiffusion on the individuality and sexual origin of blood stains. *J. Forensic Sci.* 21: 498-509
- Sweet, G. H., D. E. Wilson and J. D. Gerber. 1973. Application of electroimmunodiffusion and crossed electroimmunodiffusion to the comparative serology of a microorganism (*Histoplasma capsulatum*). *J. Immunol.* 111: 554-564
- † Svensson, H. 1948. Preparative electrophoresis and ionophoresis. *Adv. Protein Chem.* 4: 251-295
- † Svensson, H. 1961. Isoelectric fractionation, analysis and characterization of ampholytes in natural pH gradients. I. The differential equation of solute concentrations at a steady state and its solution for simple cases. *Acta Chem. Scand.* 15: 325-341
- † Svensson, H. 1962a. Isoelectric fractionation, analysis and characterization of ampholytes in natural pH gradients. II. Buffering capacity and conductance of isoionic ampholytes. *Acta Chem. Scand.* 16: 456-466
- † Svensson, H. 1962b. Isoelectric fractionation, analysis and characterization of ampholytes in natural pH gradients. III. Description of apparatus for electrolysis in columns stabilized by density gradients and direct determination of isoelectric points. *Arch. Biochem. Biophys.*, Suppl. 1: 132-138
- † Svensson, H. 1967. Separation of proteins by isoelectric focusing in stable pH gradients, in: H. Peeters (ed.) *Protides of the Biological Fluids*, Proc. of 15th Colloq., Bruges, 515-522, Elsevier Publishing Co, Amsterdam, New York and London, 1968
- Tiselius, A. 1930. The moving boundary method of studying the electrophoresis of proteins. *K. Vetenskaps-societeten in Uppsala, Nova Acta Regiae Soc. Sci. Upsaliensis* 7 (4 ser) (4): 1-107
- Tiselius, A. 1937. A new apparatus for electrophoretic analysis of colloidal mixtures. *Trans. Faraday Soc.* 33: 524-531
- Tjio, H. H. and A. Levan. 1956. The chromosomes number of man. *Hereditas* 42: 1-6 and see Boyer (1963)
- Tombs, M. P. and P. Akroyd. 1967. Acrylamide gel electrophoresis. *Shandon Instr. Applic.*, No. 18
- Topley, W. W. C., J. Wilson and J. T. Duncan. 1935. The mode of formation of aggregates in bacterial agglutination. *Br. J. Exp. Pathol.* 16: 116-120
- Turba, F. and H. J. Enenkel. 1950. Elektrophorese von Proteinen in Filterpapier. *Naturwissenschaften* 37: 93
- Van Holde, K. E., 1971. *Physical Biochemistry*, Prentice Hall, Inc., Englewood Cliffs, N. J.
- van Oss, C. J. 1973. Precipitation and agglutination, in: N. R. Rose, F. Milgrom and C. J. van Oss (eds.) *Principles of Immunology*, 30-55, Macmillan Publishing Co., New York
- van Oss, C. J., J. F. Mohn and R. K. Cunningham. 1978. Influence of various physicochemical factors on hemagglutination. *Vox Sang.* 34: 351-361
- Vesterberg, O. 1967. Isoelectric fractionation, analysis and characterization of ampholytes in natural pH gradients. V. Separation of myoglobins and studies on their electrochemical differences. *Acta Chem. Scand.* 21: 206-216
- Vesterberg, O. 1973. Physicochemical properties of the carrier ampholytes and some biochemical applications. *Ann. N.Y. Acad. Sci.* 209: 23-33
- Vesterberg, O. 1975. Some aspects of isoelectric focusing in polyacrylamide gels, in: J. P. Arbutnot and J. A. Beeley (eds.) *Isoelectric Focusing*, 78-96, Butterworths, London
- Vesterberg, O. and H. Svensson. 1966. Isoelectric fractionation, analysis and characterization of ampholytes in natural pH gradients. IV. Further studies on the resolving power in connection with separation of myoglobins. *Acta Chem. Scand.* 20: 820-834
- Walton, H. F. 1975a. Principles of ion exchange, in: E. Heftmann (ed.) *Chromatography, A Handbook of Chromatographic and Electrophoretic Methods*, 3rd ed., 312-343, Van Nostrand Reinhold Co., New York, Cincinnati, etc.
- Walton, H. F. 1975b. Techniques and applications of ion-exchange chromatography, in: E. Heftmann (ed.) *Chromatography, A Handbook of Chromatographic and Electrophoretic Methods*, 3rd ed., 344-361, Van Nostrand Reinhold Co., New York, Cincinnati, etc.
- Warburg, O. and W. Christian. 1942. Isolierung und Kristallisation des Gärungsferments Enolase. *Biochem. Z.* 310: 384-421
- Watson, J. D. 1976. *Molecular Biology of the Gene*, 3rd ed., W. A. Benjamin Inc., Menlo Park, CA, Reading, MA, etc.
- Watson, J. D. and F. H. C. Crick. 1953a. Molecular structure of nucleic acids. A structure for deoxyribose nucleic acid. *Nature* 171: 737-738
- Watson, J. D. and F. H. C. Crick. 1953b. Genetical implications of the structure of deoxyribonucleic acid. *Nature* 171: 964-967
- Watson, J. D. and F. H. C. Crick. 1953c. The structure of DNA. *Cold Spring Harbor Symp. Quant. Biol.* 18: 123-131
- Weeke, B. 1973a. Rocket immunoelectrophoresis, in: N. H. Axelsen, J. Kroll and B. Weeke (eds.) *A Manual of Quantitative Immunoelectrophoresis*, *Scand. J. Immunol.* 2, suppl. 1: 37-46, Universitetsforlaget, Oslo, Bergen and Tromso
- Weeke, B. 1973b. Crossed immunoelectrophoresis, in: N. H. Axelsen, J. Kroll and B. Weeke (eds.) *A Manual of Quantitative Immunoelectrophoresis*, *Scand. J. Immunol.* 2, suppl. 1: 47-56 Universitetsforlaget, Oslo, Bergen and Tromso
- Weichselbaum, T. E. 1946. An accurate and rapid method for the determination of proteins in small amounts of blood serum and plasma. *Am. J. Clin. Pathol.* 16 containing Tech. Sect. 10: 40-49
- Weinberg, W. 1908. Über den Nachweis der Vererbung beim Menschen. *Jahreshefte Ver. Vaterland. Naturkd. Württemberg, Stuttgart* 64: 368-382 through S. H. Boyer (ed.) 1963
- Wellner, D. and M. B. Hayes. 1973. Isoelectric focusing in polyacrylamide gels. *Ann. N.Y. Acad. Sci.* 209: 34-43
- Whitehead, P. H., S. S. Kind, P. A. Morris, M. Davies and R. Cleevly. 1970. The examination of blood stains by Laurell electrophoresis (antigen/antibody crossed electrophoresis). *J. Forensic Sci. Soc.* 10: 83-90
- Wieme, R. J. 1965. *Agar Gel Electrophoresis*, Elsevier Publishing Co., Amsterdam, New York and London
- Wieme, R. J. 1975. Theory of electrophoresis, in: E. Heftmann (ed.) *Chromatography*, 3rd ed., 228-281, Van Nostrand Reinhold Co., New York, Cincinnati, etc.
- Wiener, A. S. and M. Herman. 1939. The second stage of the agglutinative reaction. *J. Immunol.* 36: 255-259
- Williams, R. C., Jr. 1971. Cold agglutinins: studies of primary structure, serologic activity and antigenic uniqueness. *Ann. N.Y. Acad. Sci.* 190: 330-341
- Wilson, A. T. 1964. Direct immunoelectrophoresis. *J. Immunol.* 92: 431-434
- Wilson, R. S. 1970. Blood typing and twin zygosity. *Hum. Hered.* 20: 30-56
- Wraxall, B. G. D. and B. J. Culliford. 1968. A thin-layer starch gel method for enzyme typing of bloodstains. *J. Forensic Sci. Soc.* 8: 81-82
- Wunderly, Ch. 1959. Paper electrophoresis, in: M. Bier (ed.) *Electrophoresis, Theory Methods and Applications*, 179-223, Academic Press, New York
- Zmijewski, C. M. and J. L. Fletcher. 1972. *Immunohematology*, 2nd ed., Appleton Century Crofts, Meredity Corp., New York
- Zubay, G. L. (ed.) 1968. *Papers in Biochemical Genetics*, Holt, Rinehart and Winston, New York, Chicago, etc.
- Zubay, G. L. and J. Marmur (eds.) 1973. *Papers in Biochemical Genetics*, 2nd ed., Holt, Rinehart and Winston, New York, Chicago, etc.

† Known as H. Rilbe after 1968