

The author(s) shown below used Federal funds provided by the U.S. Department of Justice and prepared the following final report:

Document Title: Characterization of Weapons Used in Stab Attacks – Phase II: Surrogate Development, Final Report

Author(s): Nicholas Shewchenko, Doug Baines

Document No.: 249551

Date Received: December 2015

Award Number: 2011-DE-BX-K003

This report has not been published by the U.S. Department of Justice. To provide better customer service, NCJRS has made this federally funded grant report available electronically.

Opinions or points of view expressed are those of the author(s) and do not necessarily reflect the official position or policies of the U.S. Department of Justice.



Characterization of Weapons Used in Stab Attacks – Phase II: Surrogate Development FINAL REPORT

Report No.:
R13-11

Date:
2014-03-27

Status:
Commerical in Confidence

Prepared for:
Cynthia Bir
Nicholas Rowley

Wayne State University
818 W Hancock
Detroit, MI 48202

Authors:
Nicholas Shewchenko
Doug Baines

Biokinetics and Associates Ltd.
2470 Don Reid Drive
Ottawa, Ontario, K1H 1E1
Canada

www.biokinetics.com

(this page intentionally left blank)

Prepared by: Nicholas Shewchenko



Approved by: Nicholas Shewchenko



Distributed to: Dr. J.M. Cavanaugh

2014-03-27

(this page intentionally left blank)

Preface

This report constitutes the final deliverable for the program titled “Characterization of Weapons used in Stab/Slash Attacks”. This version of the report summarizes Phases I, II and III activities related to developing an initial taxonomy for classifying threats found in correctional and law enforcement environments, development of exemplar threats derived from the classified threats, and finally, the validation and performance characterization of the exemplars.

(this page intentionally left blank)

Table of Contents

1.	Introduction.....	1
1.1	Background.....	1
1.2	Weapons.....	2
1.3	Weapon Usage	2
1.4	Weapon Construction	4
1.5	Weapon Attributes and Characterization	5
1.6	Weapon Interactions	7
2.	Weapon Database and Survey	9
2.1	Weapon Survey	9
2.2	Weapon Database Development	10
2.3	Database Entry Guidelines	13
3.	Taxonomy Development	14
3.1	Objective	14
3.2	Initial Weapon Classes – Improvised vs. Commercial	14
3.3	Taxonomy Objectives	15
3.4	Taxonomy Methods	15
3.5	Weapon Typology	16
3.6	Descriptive Taxonomy Results	24
4.	Weapon Down-Selection.....	26
5.	Taxonomy – Performance Based.....	27
5.1	Weapon Characterization Requirements	27
5.2	Tip Sharpness Test Methodology	27
5.3	Edge Sharpness	28
5.4	Weapon Hardness	29
5.4.1	Background	29
5.4.2	Methods.....	29
5.4.3	Results.....	30
5.5	Push-through Tests.....	30
5.5.1	Background	30
5.5.2	Methods.....	31
5.5.3	Results.....	32
6.	Exemplar Weapon Development.....	35
6.1	Basis for Exemplars	35
6.2	Geometry	35
6.3	Buckling Modes.....	37
6.4	Flexural Stiffness	38
6.5	Materials	38
6.6	Exemplar Design.....	40
7.	Exemplar Evaluations.....	43
7.1	Quasi-Static	43
7.1.1	Methods.....	43
7.1.2	Results.....	43
7.2	Dynamic.....	45
7.2.1	Methods.....	46
7.2.2	Results.....	46
8.	Summary and Recommendations	49
9.	Acknowledgements	50

10. References	51
Appendix A : Weapon Data Entry Table	A-1
Appendix B : Stab Weapon Measurement Guide	B-1
2 Weapon Styles:	B-4
2.1 Bladed	B-4
2.2 Ice Pick Style	B-4
2.3 Stake	B-5
2.4 Slash Style Weapon.....	B-5
3 Measurements.....	B-6
3.1 Overall Weapon Length:	B-6
3.2 Overall Weight:	B-6
3.3 Tip	B-6
3.3.1 Tip Material.....	B-6
3.3.2 Tip Shape Description	B-7
3.3.3 Tip Radius (mm)	B-7
3.3.4 Tip Cone Angle (deg)	B-7
3.3.5 Tip Width (mm)	B-8
3.3.6 Tip Length (mm)	B-8
3.3.7 Tip Surface Finish.....	B-8
3.3.8 Tip Hardness	B-8
3.4 Edge.....	B-8
3.4.1 Edge Condition	B-8
3.4.2 Edge Radius, Edge No. 1 (mm).....	B-9
3.4.3 Edge Cone, Edge No. 1 (deg)	B-9
3.4.4 Edge Radius, Edge No. 2 (mm).....	B-9
3.4.5 Edge Cone, No. 2 (mm).....	B-9
3.4.6 Edge Grind Sides, Edge No. 1	B-9
3.4.7 Edge Grind Sides, Edge No. 2	B-10
3.4.8 Edge 1 Tip - Start (mm)	B-10
3.4.9 Edge 1 Length (mm).....	B-10
3.4.10 Edge 2 Tip - Start (mm)	B-10
3.4.11 Edge 2 Length (mm)	B-10
3.4.12 Edge Hardness	B-10
3.5 Blade	B-10
3.5.1 Blade Material.....	B-10
3.5.2 Blade Shape - planar	B-11
3.5.3 Blade Spine	B-11
3.5.4 Blade Serrations (describe)	B-11
3.5.5 Blade Width (mm).....	B-11
3.5.6 Spike Diameter (mm).....	B-12
3.5.7 Blade Thickness (mm).....	B-12
3.5.8 Blade Surface Finish	B-12
3.5.9 Blade Hardness	B-12
3.6 Handle.....	B-12
3.6.1 Handle Length (mm).....	B-12
3.6.2 Handle Tang	B-12
3.6.3 Handle Guard	B-12
4 Performance Variables.....	B-13
4.1 Armour System Description	B-13
4.2 Perforation (mm)	B-13
4.3 Stroke.....	B-13
4.4 Stroke Start (mm).....	B-13
4.5 Stroke End (mm).....	B-13

4.6	Peak Force (N).....	B-13
4.7	Plateau Force Start (N)	B-14
4.8	Plateau Force End (N)	B-14
4.9	Plateau Force Slope (\pm N/mm)	B-14
4.10	Energy (J)	B-14
4.11	Failure Mode; Armour	B-14
4.12	Failure Mode; Threat.....	B-14
4.13	Video.....	B-14
4.14	Fair/Un-fair Test.....	B-14
Appendix C : Push-through Testing Guidelines.....		C-15
1	Introduction.....	C-16
2	Materials and Equipment.....	C-16
3	Methods.....	C-17
3.1	Instron Preparation	C-17
3.2	Armour Clamping.....	C-17
3.3	Armour Backing Support and Witness Paper	C-17
3.4	Weapon clamping	C-18
3.5	Operating Parameters.....	C-18
3.6	Measurements	C-18
3.6.1	Sign Conventions and Units	C-18
3.6.2	Perforation (mm).....	C-18
3.6.3	Stroke at Peak (mm).....	C-19
3.6.4	Stroke L1/2/3 Start (mm)	C-19
3.6.5	Stroke L1/2/3 End (mm)	C-19
3.6.6	Force L1/L2/L3 Start (N).....	C-19
3.6.7	Force L1/L2/L3 End (N)	C-19
3.6.8	Force Slope L1/L2/L3 (N/mm)	C-19
3.6.9	Peak Force (N)	C-20
3.6.10	Energy (J)	C-20
3.6.11	Failure Mode; Armour	C-20
3.6.12	Fair/un-fair Test.....	C-20
3.6.13	Failure Mode; Threat.....	C-20
3.6.14	Video.....	C-20
3.7	Initial Setup and Measurement Initialization	C-21
3.7.1	Test Sample Placement	C-21
3.7.2	Weapon Clamping and Placement	C-21
3.7.3	Pre-test Setup.....	C-21
3.8	Test Execution	C-22
4	Data Collection and Processing	C-22
5	Documentation	C-22
Appendix D : Exemplar Threats Engineering Drawings		D-1

(this page intentionally left blank)

List of Tables

Table 1: Summary of stab attack inputs and response against armour.	3
Table 2: Summary of slash attack inputs and response against armour.	3
Table 3: Attributes of a bladed weapon.	4
Table 4: Proposed weapon typology parameters.	6
Table 5: Definition of weapon types in the survey.	10
Table 6: Description of various stages of weapon database population.	11
Table 7: Initial descriptive weapon taxonomy.	12
Table 8: Weapon attributes and system level ranking scheme.	19
Table 9: Weapon Value weightings.	20
Table 10: Tip Value weightings.	21
Table 11: Tip Material weightings.	21
Table 12: Tip Aggressiveness weightings.	21
Table 13: Range of Tip Values based on TM and TA.	21
Table 14: Edge Value weightings.	23
Table 15: Edge Condition weightings.	23
Table 16: Edge Number weightings.	23
Table 17: Edge Material weightings.	23
Table 18: Weapon down selection sample sizes and performance tests.	27
Table 19: Geometric data for the bladed weapon subset.	36
Table 20: Geometric data for the spiked weapon subset.	37
Table 21: Performance assessments of bladed weapon subset.	39
Table 22: Performance assessments of spiked weapon subset.	40
Table 23: Geometric data for the bladed exemplars.	41
Table 24: Geometric data for the spiked exemplars.	41
Table 25: Quasi-static performance of bladed exemplars.	43
Table 26: Quasi-static performance of spiked exemplars.	44
Table 27: Final exemplar specifications.	45
Table 28: Test matrix for dynamic assessment of the exemplar threats.	46
Table 29: Dynamic evaluation results of the bladed exemplars.	47
Table 30: Dynamic evaluation results of the spiked exemplars.	47
Table 31: L ₅₀ assessment for all exemplars.	48

(this page intentionally left blank)

List of Figures

Figure 1: Weapon's effectiveness assessment process.....	1
Figure 2: Attributes of a bladed weapon (from Wikipedia).....	4
Figure 3: Weapon and armour failure tree.....	7
Figure 5: Distribution of weapons by type.	9
Figure 6: Depiction of data reduction in the weapon classification process.	14
Figure 7: Taxonomy process used for exemplar development.....	16
Figure 8: Initial stab weapon descriptive groupings.....	17
Figure 9: Weapon performance assessment with a hierarchal structure of attributes.....	18
Figure 10: Weapon system ranking scheme incorporating tip, edge and blade attributes.	20
Figure 11: Tip Value topography based on weapon penetrability and material.....	22
Figure 12: Edge Value topography based on edge condition and quantity.	23
Figure 13: Weapon value rankings for bladed styles.....	24
Figure 14: Weapon value rankings for spiked styles.	24
Figure 15: Weapon value rankings for stake styles.	25
Figure 16: Weapon Value rankings of the down selected group based on descriptive typology.	26
Figure 17: Tip sharpness indenter test setup (courtesy of WSU).	28
Figure 18: Typical tip resistance force response.	28
Figure 19: Edge sharpness test setup (courtesy of WSU).	29
Figure 20: A typical Rockwell hardness tester and; Rockwell "B" spherical ball indenter.	30
Figure 21: Push-through test components and setup.....	31
Figure 22: Push-through test setup (courtesy of WSU).....	31
Figure 23: Push-through bladed weapon force test results.	32
Figure 24: Push-through spiked weapon force test results.	33
Figure 25: Push-through blade test performance and attributes.	33
Figure 26: Push-through spike test performance and attributes.....	34
Figure 27: Subset of bladed weapons used for exemplar design.....	35
Figure 28: Subset of ice-pick weapons selected for exemplar design.....	36
Figure 31: Experimental setup for flexural stiffness (courtesy of WSU).	38
Figure 32: Blade exemplar T1.	42
Figure 33: Blade exemplar T2.	42
Figure 34: Spike exemplar T3.....	42
Figure 35: Spike exemplar T4.....	42
Figure 36: Quasi-static performance plots for the exemplars.	44
Figure 37. Armour penetration probability.	45
Figure 38: Dynamic test results of exemplar threats with various armour materials and layers.	48
Figure 39 Bladed Style (pictures courtesy of Wayne State University).	B-4
Figure 40 Ice Pick Style.....	B-5
Figure 41 Stake Style	B-5
Figure 42 Slash Style.....	B-6
Figure 43 Overall Weapon Length.....	B-6
Figure 44 Symmetrical.....	B-11
Figure 45 Rounded	B-11
Figure 46 Square	B-11
Figure 47 Triangular	B-11
Figure 48 Serrated.....	B-11
Figure 49: Instron test setup.....	C-16
Figure 50: Armour sample backing support and witness paper setup, sectional view.	C-17
Figure 51: Typical force-displacement plot of an Instron head during a quasi-static test.	C-21

(this page intentionally left blank)

1. Introduction

This report summarizes the activities related to support of the first two phases of the stab weapons' characterization program being conducted by Wayne State University (WSU) for the development of an updated stab/slash body armour performance standard by the National Institute of Justice.

The objectives of the overall work relate to the Statement of Work outlined under WSU contract No. 2011-DE-BX-K003 and encompass the following:

Phase I:

- Development of an initial weapon typology based on literature.
- Survey commercial stab-resistant armours to identify current technologies available in North American.

Phase II

- Finalize the weapon typology.
- Down select the weapons and summarize performance attributes.
- Develop an initial set of weapon exemplars.

Phase III

- Carry out validations of the exemplar weapons, optimize if required.
- Characterize the performance of the exemplars with standard armour.

It can be noted that during the course of research with WSU and in discussion with the Special Technical Committee responsible for update of the Stab Resistance of Personal Armor standard NIJ 0115.00, the scope of the work was altered to address only improvised stab weapons. The proposed typology and analysis approach were therefore suited to improvised stab weapons used in a forward thrust mode although the analysis is amenable to commercial weapons used in a similar fashion.

1.1 Background

Injuries due to stab or slash attacks is of concern to corrections and law enforcement officers alike. Approximately 13% of law enforcement officers were assaulted by knives or cutting instruments according to the 2009 Law Enforcement Officers Killed and Assaulted (LEOKA) report. While similar statistics for corrections environment are not collated at present, it is likely that similar concerns exist from spiked or bladed weapon attacks. However, the types of weapons used, mode of use and effectiveness in defeating protective armour is not well known.



Figure 1: Weapon's effectiveness assessment process.

The study and characterization of weapon effectiveness in defeating protective armour must consider all actions from weapon delivery, armour interaction to injury outcome, Figure 1. The attack process is a dynamic event and cannot be fully characterized by static or quasi-static analysis. This is partly due to the limited amount of energy available by the assailant to administer the blow, and the energy consumed during the interaction with the armour system. The study of weapon delivery modes and associated kinematics and kinetics was carried out over several studies [Chadwick, Nicol et al. 1999; Watson, Horsfall et al. 2000; Bleetman, Watson et al. 2004]. Values for weapon delivery speed, trajectory, force and energy from simulated attacks on armoured surrogates with volunteers were presented. This will be discussed in more detail in later sections.

Atkins reported on studies involving the science of cutting and mentions several modes of energy dissipation during the perforating, cutting and sawing modes of cutting tools including knives [Atkins 2009]. These include, in part, energy dissipation during material cracking, tensile failure, friction, and material deformation. The depth of penetration of a weapon will therefore be dictated when equilibrium is reached between the applied (available) and resisted (dissipated) energies, highlighting the need to characterize weapons in a dynamic manner involving interactions with the armour system.

For completeness, the true impact of the weapon and potential for injury must account for the availability of weapons, their frequency of use, mode of use and prevalence of body armour. The question remains as to how all, or some, of these factors can be assimilated into a scheme for not only ranking weapon effectiveness but also for consolidating these into a few exemplars for use in test standards.

One standard approach utilized by the National Academy of Science for assessing the outcome of a threat, whether it be a weapon, toxin or pharmaceutical, can provide a good basis for assessing stab weapon effectiveness. The approach, however, requires information on the type of hazard, the dose-response relationship, exposure assessment and risk characteristics. This approach was adopted by the U.S. Department of Defense Joint Non-Lethal Weapon Directorate to evaluate the anticipated effects of non-lethal weapons under various scenarios. However, due to the paucity of literature on stab attacks, a simplified approach is required to meet the current programs' objective of weapon characterization and exemplar development. Therefore, the overall approach will place emphasis on the physical and geometric characteristics of stab weapons found in correctional and law enforcement environments. Additional effort to characterize weapon performance against armoured systems will also be conducted to understand the weapon interactions and related attributes on performance.

1.2 Weapons

An extremely wide range of edged or pointed weapons has been used in history during attacks to personnel from organized battles to acts of spontaneous violence. In the context of current day law enforcement officers and corrections personnel, the weapons of interest range from knives, spikes, awls, blades, needles, machetes and other blade or pointed weapons originating from commercial sources to those fashioned by hand. Commercial knives are designed to suit specific needs such as hunting, camping, utility, survival, ceremonial, combat, and food preparation, to name a few. As a result, these vary considerably in blade construction, materials, geometry, and handle design.

1.3 Weapon Usage

The method in which weapons are used will have a substantial affect on their effectiveness to overcome body armour, if worn, and inflict harm. Different motions of delivering the weapon such as a thrust or slash and the energy involved will also greatly influence the outcome. Similarly, the defensive actions or inactions taken by the victim can lead to different injury outcomes with different implications on weapon effectiveness or armour requirements.

An initial literature review was conducted on stab and slash weapons to identify typical usage modes and forces involved as this may highlight certain characteristics or interaction modes of the weapons. For example, weapons used in a forward thrust mode place more emphasis on penetrability than compared to a slash weapon where the edge sharpness plays a larger role for defeating armour or for injury potential.

Two primary modes of knife attack have been identified in the literature, thrust and slash attacks [Chadwick, Nicol et al. 1999; Horsfall 2000; Watson, Horsfall et al. 2000; Carr, Kemp et al. 2010]. Thrust attacks may involve a plunge and drag phase while slash attacks involve a more lateral sweep across the body. The effect of the attack mode on body armour construction can be large with thrust attacks requiring thick, heavy armour to defeat penetrating threats [Chadwick, Nicol et al. 1999; Bleetman, Watson et al. 2004; Croft and Longhurst 2007]. In contrast, slash attacks can be resisted with lighter, more flexible armour.

Table 1: Summary of stab attack inputs and response against armour.

Attack speed	8.4 m/s
Momentum transfer	68 kg m/s
Energy transfer	69 J
Peak measured axial force	1885 N

In the published studies, three modes of bladed weapon use were established in consultation with police; a short forward thrust, overhand stab and horizontal sweep [Chadwick, Nicol et al. 1999]. Each style produced unique loading characteristics measured with an instrumented handle. Volunteers from the police force conducted tests on a Kevlar armour situated on foam and clay targets. The measured responses of the attack, impact and arresting phases were summarized. The 95th percentile values are presented in Table 1.

The loads were commented to be high as a result of the strength and skills of the volunteers. Suggestion was made to provide multiple levels of performance to match different threat situations. High lateral and torsional loads were also noted and primarily associated with the horizontal sweep. Blade strength and rigidity and handle design were viewed as an important aspect of the weapon in order to withstand these loads.

In a study of simulated slash attacks, differences in delivery method and initial strike velocity were noted. Experiments with volunteers resulted in slash impact speeds in the range of 6-10 m/s but achieved peak forces 25% lower than found for stabbings [Chadwick, Nicol et al. 1999; Watson, Horsfall et al. 2000]. Impact speeds for stab were found to be similar for thrust and overhand approaches, 6.6-12 m/s [Miller 1998]. In another study, Bleetman, [Bleetman, Watson et al. 2004], reported on simulated slash attacks based on the test methods and data of Watson, [Watson, Horsfall et al. 2000]. Horizontal and diagonal slash patterns were studied with Kevlar and foam targets with a witness paper facing. Student volunteers were used and the 95th percentile values for all attack modes are presented in Table 2. It can be noted that the reaction forces are considerably less than for stab supporting the notion that less robust armour is required to resist slash attacks.

Table 2: Summary of slash attack inputs and response against armour.

Attack speed	10.6 m/s
Peak measured force	175 N

1.4 Weapon Construction

For reference, the basic construction and definitions of a commercial weapon are depicted in Figure 2 with many descriptors being shared with improvised weapons. While these are physical descriptors of the weapon elements, they are also responsible for its function and will be treated synonymously as such in the subsequent classification efforts.

Table 3: Attributes of a bladed weapon.

Attribute	Function
1 Blade	assembly, may include tang
2 Handle	weapon support and force application
3 Point, Tip	piercing
4 Edge	cutting
5 Grind	edge support, wedging
6 Spine	blade stiffener
7 Fuller	lightening grooves
8 Ricasso	thickening at base of blade
9 Guard	blade termination, hand protection
10 Butt	handle termination
11 Lanyard	weapon retention

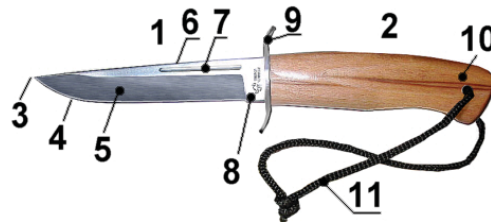

Figure 2: Attributes of a bladed weapon (from Wikipedia).

In regards to stab/slash attacks research studies have discussed the weapon attributes in relation to human injury and armour failure [Chadwick, Nicol et al. 1999; SECRU 1999; Horsfall 2000; Watson, Horsfall et al. 2002; Bleetman, Watson et al. 2004; Carr, Kemp et al. 2010; Fenne 2010]. Terms such as tip sharpness, edge sharpness, body slimness/shape, surface finish and material have been reference and associated with the weapon's performance. A quantitative understanding of a weapon performance attributes can be gained from an engineering study of weapons by Atkins who quantified the primary modes of action including piercing, cutting, parting/wedging, and sawing [Atkins 2009]. These actions are related to physical attributes of the weapon such as the tip and edge, including their approach angle, tip radius, included cone angle, among others. A list of relevant attributes to stab and slash modes is presented in Table 7. The hierarchy of the attributes is broken down to represent the primary modes of function, *i.e.* the tip attributes are responsible for piercing performance.

It should also be noted that weapon performance is a function of the material with which it interacts and the action which it is to perform. Brittle armour materials, for example, may fail by a different means than ductile ones and place more emphasis on the grind of the weapon than the edge sharpness due to their different roles during crack propagation. Further, a kitchen knife is meant to be operated with a light downward pressure on the edge combined with a lateral slicing action to cut and separate materials. The same knife used for a stab or thrust action against armour may result in dulling or fracture of the tip/edge and even bending of the blade, making it ill suited to those modes of use.

In order to address the performance of the weapon against different materials, attributes for including experimental perforation test results are included as supplemental information to the physical attributes. These can be found at the end of Table 7.

1.5 Weapon Attributes and Characterization

Several key physical attributes of a weapon have been considered in the literature when assessing the injury potential of a given weapon. Three attributes that have been identified include the tip sharpness, edge sharpness and friction [Horsfall 2000; Watson, Horsfall et al. 2002; Fenne 2010]. The mechanisms of performance for each attribute were not elaborated upon by the authors, however, insight can be gained from Atkins' engineering analysis of cutting tools [Atkins 2009].

In the context of stab or slash type weapons, physical attributes responsible for failure of the target are proposed to involve the following.

- The tip of the weapon is responsible for initiating perforation of the target possibly leading to reduced effort for subsequent penetration and creation of an opening for wedging action of the tool. The opening may involve crack propagation for some materials.
- The edge of the weapon provides a cutting action, which can lead to material separation (e.g. parting, wedging, material removal and cracking) depending on the angle of attack, bladed design (e.g. serrations), target materials and push/slice force ratio.
- The surface finish of the tip, edge and blade due to the high normal forces involved with the weapon as it penetrates into the target material.

Additional modes of cutting were presented by Atkins but are not reported on herein due to their greater relevancy to machine cutting tools or implements not common to stab or slash type threats.

Quantification of the tip or edge by Atkins is based on the geometric and materials characteristics for the particular area of interest. Tip/edge radius, included angle of the sides, the presented angle and application of normal and tangential forces have been described and highlight important aspects of weapon performance. Material strength/hardness and toughness are also presented in terms of the ability of the weapon to withstand interactions with the target materials for single or multiple times.

For the current weapon characterization study, quantification of the geometric attributes is beyond the planned scope with preference to study interactions of the weapon with the intended armour system as this has an equally important role in determining weapon performance. By design, armour systems are intended to defeat the weapon by its partial destruction and therefore ranking the performance of a weapon against a benign target versus an armour system will likely provide very different outcomes. A scalpel can cut tissue very well but may dull or break when penetrating or cutting a metallic or ceramic plate, for example.

Due to the importance of weapon/armour interaction in assessing performance, empirical methods for quantifying performance are more desirable than analytical methods due to the large variety of available weapons and armour systems. The survey data from WSU, reported elsewhere, has shown a wide variety of weapons from correctional institutes. Weapons used in a correctional institute are more often fabricated from available materials and fabrication methods and are therefore not structured as one would expect with commercial weapons found in street use.

Numerous empirical methods for assessing sharpness¹ of a weapon or cutting tool attempt to quantify the relative performance against a standard target. Sharpness within the food and commercial industries can be determined using several proposed techniques involving cutting

¹ The term "sharpness" is an oversimplification of the weapon's performance for the reasons provided above, however, it will be used from this point forward in the report for consistency.

[McGorry and Dowd 2005; McGorry and Dowd 2005b; Marsot and Claudon 2007; Gilchrist and Keenan 2008]. The Cutlery and Allied Technology Research Association (CATRA) has also developed sharpness test methods for use with food items, *i.e.* BS EN ISO 8442-5, Razor Edge Durability and Sharpness (REDS). However, the applicability of these test methods with armour systems has not been established. Watson et al. studied tip/edge sharpness test methods involving indenters as well as a edge cutting tests for slash applications [Watson, Horsfall et al. 2002]. Recommendations were made to use a Rockwell indenter type test with the threat as the indenter, which has subsequently been adopted by the HOSDB and NIJ standards [NIJ 2000; Croft and Longhurst 2007]. A prototype CATRA edge sharpness tester was also proposed but no further details were provided. Edge sharpness for slash applications was recommended to be evaluated with the BN EN ISO 8442-5 standard which has also been adopted by the HOSDB [Malbon and Croft 2006].

For the purpose of the current weapon characterization program, the above tip/edge sharpness test methods are viewed as being useful to establish initial weapon or exemplar geometry related to sharpness but with limited value for assessing single strike weapon performance on armour systems. As found by Watson, and mentioned by Atkins, the target test material and loading stresses play an important role in sharpness assessment. It is, therefore, preferred to use actual penetration tests with relevant body armour systems, *i.e.* designed to defeat the threats found in the current survey, in order to assess actual performance. This is discussed further later sections.

Table 4: Proposed weapon typology parameters.

Parameter	Context	Reference
Weapon style	Knife, spike, etc.	
Mode of use	Overhand, underhand, thrust, slash, thrown	
Blade construction description	Robustness and penetrability	
Handle description	Weapon delivery effectiveness	
Surface finish of blade (roughness, striations, orientation)s	Friction interaction with body armour	
Blade dimensions (length, width, thickness)	Penetrability	[Horsfall 2000]
Slimness or aspect ration of tip	Frictional resistance	[Horsfall 2000]
Tip sharpness	Penetrability	[Horsfall 2000]
Edge sharpness	Cutting or armour	[Watson, Horsfall et al. 2002], [Horsfall 2000]
Material composition	Penetrability	

An initial typology gleaned from the literature may take the form of the table above with descriptive parameters added for completeness. It is proposed to refine the typology and create a weapons database populated from data collected in the WSU survey in Phase I of the study. Multiple groupings of weapons will be included to provide greater specificity of the weapon type making it amenable for further analysis by this program and others in future. For example, there may exist sub-categories of bladed weapons which have distinct characteristics affecting their performance on armour systems, *i.e.* single vs. double edged, smooth vs. serrated). To consolidate bladed weapons in the typology database would then preclude further differentiation and analysis.

1.6 Weapon Interactions

The operational mechanisms of a knife or machine tool, described by Atkins [Atkins 2009], refer to the separation or removal of material. The edge sharpness, effective cutting angle, applied forces, and tool degradation are some of the factors affecting tool efficiency in performing its intended function. In comparison to the current study employing improvised weapons, many characteristics of the weapon are not optimized and other modes of operation not usually associated with cutting tools may need to be considered. For example, stab weapons typically involve variable angles of attack and, hence, the cutting edges or tips may not be optimally positioned and can vary throughout the delivery. As the current focus of the study is on penetrability, weapon attributes responsible for penetration and cutting will be considered in their idealized state. Material distortion, ripping and other modes of failure will not be considered.

To aid in the selection of weapon attributes responsible for the performance of improvised weapons, a brief overview of the weapon interactions with the body armour is presented, see Figure 3. The sequence is broken down into simplistic stages conducive to the development of a taxonomy scheme and includes armour performance metrics found in existing standards.

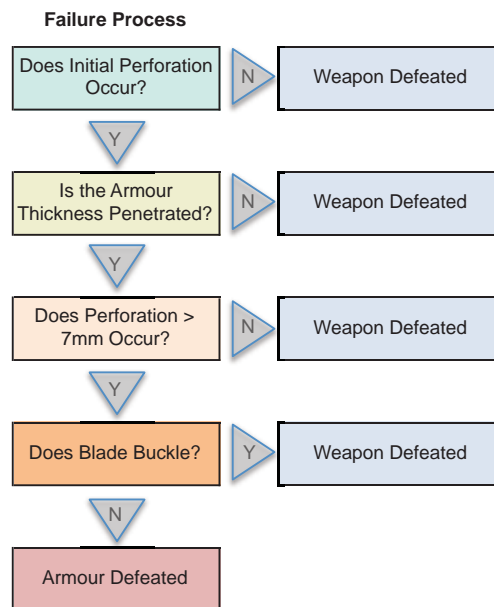

Figure 3: Weapon and armour failure tree.

The operating objective of the weapon is to defeat the armour through penetration otherwise the weapon itself will have been considered to be defeated². The armour failure process entails initial contact of the weapon's tip with the surface of the armour and subsequent perforation. This process continues until the through thickness of the armour is penetrated and eventually of sufficient magnitude to penetrate into the underlying tissue causing injury (i.e. the 7 mm penetration metric). Finally, the overall integrity of the weapon is assessed as a means to determine if it is capable of resisting the reaction forces of the armour.

² While weapons typically undergo some damage during the armour penetration process, defeat of the weapon will be considered to be gross failure resulting the weapon being inoperable.

The weapon attributes and mechanisms responsible for defeating the armour include the tip perforation by way of material separation, cracking or failure, the edge which cuts and/or wedges its way into the materials causing separation, and the blade of the weapon transmitting the applied force from the handle to the tip and edges and possibly acting as a wedge to separate materials. Due to the high resisting forces involved, substantial friction is generated against the weapon, requiring work³ to be performed for continued penetration.

The tip and edge attributes along with their associated descriptors have been suggested by others for their contribution to injury risk and armour penetration see, Section 1.5. The individual attributes, however, contribute to the overall weapon performance during the interaction process and, therefore, must be considered as a system, see Figure 4. Intrinsically, this is obvious since a sharp tip cannot perform well without a proper supporting blade and armour cannot be penetrated and cut by an edge until the tip has perforated the particular layer of armour, and so on.

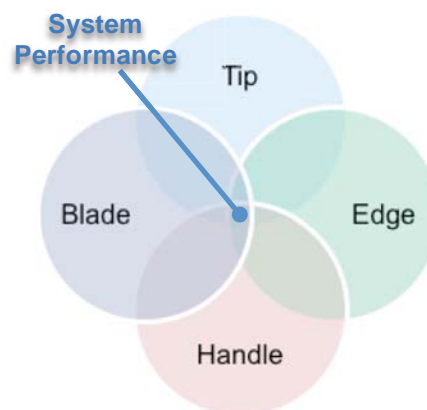

Figure 4: Weapon system performance attributes.

³ The term *work* is used in the engineering sense equating it to energy derived from the product of the force applied and penetrating distance traversed of the weapon.

2. Weapon Database and Survey

The initial phase of the program included a survey of weapons from correctional institutes spanning the United States of America. Wayne State University (WSU) undertook the survey and cataloguing effort in preparation for subsequent analysis by Biokinetics. A brief summary is provided herein for completeness.

2.1 Weapon Survey

A total of 1353 weapons were collected, photographed and catalogued in support of the weapon taxonomy and exemplar development efforts. The descriptions, measurements and notes were entered into a weapon database developed by Biokinetics and are described in later sections. Further details about the weapons survey can be found in external reports produced by WSU.

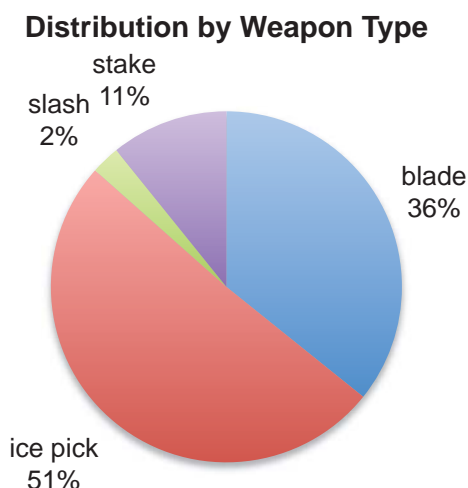

Figure 5: Distribution of weapons by type.

In summary, the collected weapons were grouped into four style categories to represent the general construction and mode of use. The weapon classification definitions are provided in Table 5 and the distribution of the weapon styles can be seen in Figure 5. This initial categorization of blades represented one level of segregation implemented at the beginning of the current effort, however, the taxonomy scheme attempted to treat all weapon attributes and characteristics in the general case so as not to bias the analysis. Nonetheless, these weapon style definitions remained during the taxonomy effort. In the current report, however, *ice picks* will be referred to more generically as *spiked weapons*.

Table 5: Definition of weapon types in the survey.

Weapon Style	Description
Blade	Flat blade with rectangular cross section generally having a tip, edge and handle. To be used in a thrust mode and possible drag/slash follow-through.
Ice Pick	A typically round shaft construction having a tip, slender shaft and handle. To be used in a thrust mode.
Stake	Similar to the blade but with an irregular cross section.
Slash	A small flat blade generally without a tip but having a supporting handle. The blade may be oriented perpendicular to the handle. To be primarily used in a slashing or sweeping mode.

2.2 Weapon Database Development

Prior to the survey, an initial typology parameter list was established to ensure that critical characteristics of the weapon are well documented. Included are descriptors of the physical weapon responsible for penetration (tip and edge sharpness, surface finish, slimness, etc.) along with information on its intended use and method of use. A detailed description of typical parameters is provided in Table 7. The parameters were based, in part, on the published research studies of [Chadwick, Nicol et al. 1999; SECRU 1999; Horsfall 2000; Bleetman, Watson et al. 2004; Carr, Kemp et al. 2010].

A desirable outcome of the survey would entail an initial assessment of stab performance against a range of body armours and usage modes, i.e. thrust, slash. However, due to many of the improvised weapons being unique, the sparse number of samples, and limited program resources, it was not possible to conduct full scale armour tests as part of the survey and therefore a stepped approach was required comprising cataloguing, approximate assessment of weapon performance through quasi-static tip sharpness, edge sharpness, and full weapon tests, Section 3.

A structured approach to data entry is required to obtain consistency of the entries and to ensure an appropriate structure for computer-aided data analysis. As will be discussed in later sections, the data entry requirements in Table 7 are needed for each weapon in the survey and therefore an Excel® worksheet was developed. To aid with data entry and analysis, the worksheet is formatted with standard database conventions utilizing records and fields, see Appendix A. The worksheet provides the data requirements for the classifications and includes field entries, processed data, nomenclature, definitions, revision record, analysis tables and plots. Extensive data error checking and confirmations were conducted to help ensure integrity of the database. The majority of the data analysis, down selection and processing was conducted within the database/worksheet making it useful for the addition of weapons or for revising the analysis rules and processes.

Implementation of the database was carried out in a stepped approach to cope with the large amount of weapons from the survey. Three levels of activity were carried out as described in Table 6 and incorporated the taxonomy processes of characterization, ranking and assimilation described in Section 3.4.

Table 6: Description of various stages of weapon database population.

Level I Characterization	An initial effort to characterize the weapons based on coarse geometric measurements and qualitative descriptors.
Level II Effectiveness	A detailed characterization of a weapon subset based on a down selection process of the Level I information. The characterization effort is to include performance measures of weapon attributes and system.
Level III Exemplar Development	Further characterization of a weapon subset from the Level II information including processed information for the development of the exemplars.

The first level catalogues the descriptions of the weapon attributes responsible for their performance. The data is used for subsequent rankings and analysis for down selection of the weapons.

The second level catalogues the effectiveness of the down selected weapons in defeating body armour. Effectiveness is assessed either by the geometric and material characteristics of the weapon, i.e. tip/edge sharpness, and by actual experimentation with representative armours allowing the weapon performance to be evaluated. The test methods developed at WSU were used as a basis for collecting performance data and comprises a controlled quasi-static push-through test with the force required to initiate perforation and subsequent push-through being documented for a sample armour. Representative armour systems are used to address differences in correctional and commercial weapon aggressiveness. The performance data will be used to further down select the weapons for subsequent classification and development of the exemplars.

The third level attempts to quantify the geometric and physical attributes of the down-selected weapons for the purpose of developing exemplars. Detailed information on the geometric, material and surface characteristics is required and heavy reliance is placed on the down-selected weapon group from the previous classification effort.

The initial typology database is presented in Table 7. It is structured by the weapon attributes responsible for their performance and includes data requirements for the three levels of population. Note that additional fields are provided to complete the description of the weapons.

A complete listing of the database entries can be found in Appendix A.

Table 7: Initial descriptive weapon taxonomy.

Phase		Attribute	Level I - Typology	Level II - Effectiveness	Level III - Exemplar Development
Asset Type		Agency Type	X	X	X
		Overall Length (mm)	X	X	X
		Overall Weight (g)	X	X	X
		Style	X	X	X
		Original Item Description	X		
Tip	Description	Material	X	X	X
		Shape Description	X	X	X
	Geometry	Radius (mm)		X	X
		Cone (deg)		X	X
		Width, Dia. (mm)		X	X
		Length (mm)		X	X
		Surface Finish		X	X
Hardness		X	X		
Edge	Description	Shape	X	X	X
		Condition	X	X	X
		No. Edges	X	X	X
	Geometry	Edge No.		X	X
		Radius (mm)		X	X
		Cone (deg)		X	X
		Cannel (mm)		X	X
		Grind sides		X	X
		Distance from Tip - Start		X	X
		Distance from Tip - Stop		X	X
Length (mm)		X	X		
Blade/Body	Description	Material	X	X	X
		Shape - planar	X	X	X
		Spine	X	X	X
		Serrations (describe)	X	X	X
		Width (mm)	X	X	X
		Length (mm)	X	X	X
		Thickness Max. (mm)	X	X	X
	Geometry and Material Characteristics	Surface Finish		X	X
		Hardness		X	X
		Diameter (mm)		X	X
	X-sec (no. corners + edges)		X	X	
Handle	Description	Cover	X	X	
		Length (mm)	X	X	
		Tang	X	X	
		Guard	X	X	
Performance Evaluation	Requirements	Stab		X	X
		Other		X	X
		Blunt Trauma		X	X

Not Required

2.3 Database Entry Guidelines

Definitions for each of the database field entries found in Appendix A was defined in the corresponding Excel® worksheet tab and in more detail in a separate document (see Appendix B). Considerable effort was spent early in the program to help ensure consistent definition and collection of the field entries. Definitions were updated throughout the data collection process in response to data entry errors and misinterpretations of the measurements. The final definitions can be found in the database worksheet.

3. Taxonomy Development

3.1 Objective

The current program's objective of creating a taxonomy or classification system for stab threats is to be able to reduce the number of weapon attributes observed from the WSU weapons survey into a small number of exemplars representative of their "performance" against personal armour systems. Emphasis is placed on their performance in order for the exemplars to exploit the different failure mechanisms and interactions between the body armour and exemplars.

The taxonomy process can involve the classification of attributes into simple groupings, the reduction of multiple attributes into a single descriptor, or the creation of new descriptors taking into account several attributes. A simplistic view, depicted in Figure 6, shows the assimilation of several weapon attributes into a reduced set that represents various performance aspects of the weapons. It is not unlikely that various performance aspects may require the development of multiple exemplars such as a spike and blade. Further, correctional weapons are expected to be divided into sub-groups once the weapon survey data has been analysed.

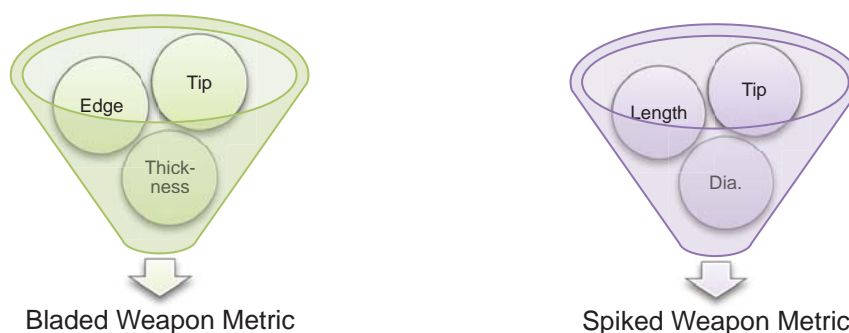

Figure 6: Depiction of data reduction in the weapon classification process.

This actual classification approach is far more detailed and involves an understanding of weapon construction, performance and interaction with armour systems, the details of which are described below.

3.2 Initial Weapon Classes – Improvised vs. Commercial

Common wisdom at the onset of the program anticipated the prevalence of some commercial weapons within the correctional institutions and anticipation that the classification scheme would be amenable to both improvised and commercial weapons.

Initial observations from the WSU weapon survey suggest that the attributes for weapons from correctional institutes are different than for commercial weapons. Sub-par materials, manufacturing methods and poor execution of the weapons are commonplace for the corrections' weapon. Further, preliminary quasi-static penetration tests conducted on aramid armour samples by WSU have shown that correctional weapons are easily defeated by less robust armour than that required for commercial/engineered threats. As a result, improvised weapons were treated as a unique population with simplified descriptors of attributes in comparison to commercial weapons. Within the improvised weapons, a breakdown by weapon style was set out at the beginning of the survey as discussed in Section 2.1 with four groupings being defined (e.g. blade, ice pick, stake, slash).

3.3 Taxonomy Objectives

It is recognized that the weapons in the survey contain a wide range of weapon types that are individually hand fashioned and unique in many ways. A method is desired to consolidate the large set of weapons into a small set of groupings based on some objective function, or functions, with the ultimate goal to develop a few exemplars.

At the onset of the taxonomy effort, the overarching goal was defined as being able to rank the weapons based on their performance. Specifically, this will be stated as:

*“The ability of a weapon to **penetrate** an **armour** system sufficiently to cause bodily **injury**.”*

The above objective includes some important assumptions that should be highlighted as this has a direct bearing on the overall selection of the weapons and eventual development of the exemplars.

- First, is the weapon’s ability to **penetrate** as this is the mode of injury or armour defeat mechanism that is being sought for the current analysis. Similarly, one could consider slashing, chopping or blunt impact mechanisms of trauma but these were beyond the current scope of the program.
- Second, is recognizing the weapon’s interaction with **armour** systems intended to defeat the threat in so much as to reduce the potential for injury. Sole tissue interactions are not being considered as it is assumed the attacked body region is protected with armour.
- Third, is that the **injury** severity is to be based on the behind armour penetration depth into the body. Underlying blunt trauma or non-life-threatening tissue disruption is not considered.

3.4 Taxonomy Methods

Developing a typology for stab weapons has been noted to involve developing a performance metric, which satisfies the objective function, discussed above. Every aspect of the weapons’ use from delivery, to interaction and penetration of the armour must be accounted for accurate assessment. However, due to the large sample size of the survey (>1300 weapons) the time and effort required to conduct a detailed review of all weapons would be prohibitive under the scope of the current program. Further, quantitative knowledge of the attributes responsible for the performance of the weapons is not known in advance, making their identification difficult.

To satisfy the program objectives, a tiered scheme was developed to aid in the development of the exemplars utilizing weapon survey information and empirical data, Figure 7.

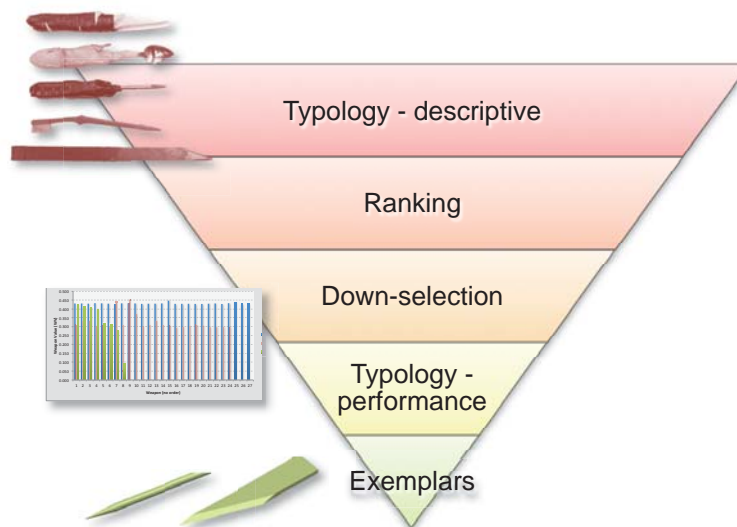

Figure 7: Taxonomy process used for exemplar development.

The **first** tier involves creating a typology for the weapons. This entails creating an initial classification scheme reflecting the objectives of the study. An initial descriptive typology was created, Table 7, based on performance related attributes such as the tip and edge. The typology allows for weapon sorting and grouping into coarse subsets such as bladed and spiked weapons along with tip, edge and blade attributes.

The **second** tier involves ranking the typology data by various metrics; typically performance based ones, so that they represent the weapon as a whole. This may entail measures such as tip/edge sharpness and blade integrity determined from predictive functions. A multi-criterion decision making process is used for the initial ranking of the weapons to handle the different forms of data (textual, numerical, ordinal, etc.).

The **third** tier involves a down-selection of the weapons to identify those of significant threat in terms of performance. This allows for more detailed measurements and tests to be performed on a smaller sample size and entails identifying the upper percentiles of the weapons possessing attributes or performance characteristics of interest.

The **fourth** tier establishes a typology based on weapon component and system performance data obtained from experimentation on the down-selected weapons.

The **fifth** tier consolidates the weapons into coarse groupings for development of bladed and spiked weapon exemplars. This involves ranking of the performance data and assimilation of the weapon geometric data to obtain representative physical and performance specifications. Averaging of dimensions, bounding of the data or taking the outer limits are examples of what the process may entail.

3.5 Weapon Typology

The structure of the weapon typology was broken down into three coarse groupings to better understand the weapon attributes and aid with the ranking and down selection processes. Three categories of weapon descriptors are depicted in Figure 8.

The first category describes the physical attributes such as its geometry (e.g. length, thickness, width, angle), shapes, number of cutting edges, handle construction, materials used and other parameters that help describe the weapon. This grouping is useful for the initial cataloguing of the weapons in the survey while providing valuable information for the down-selection process.

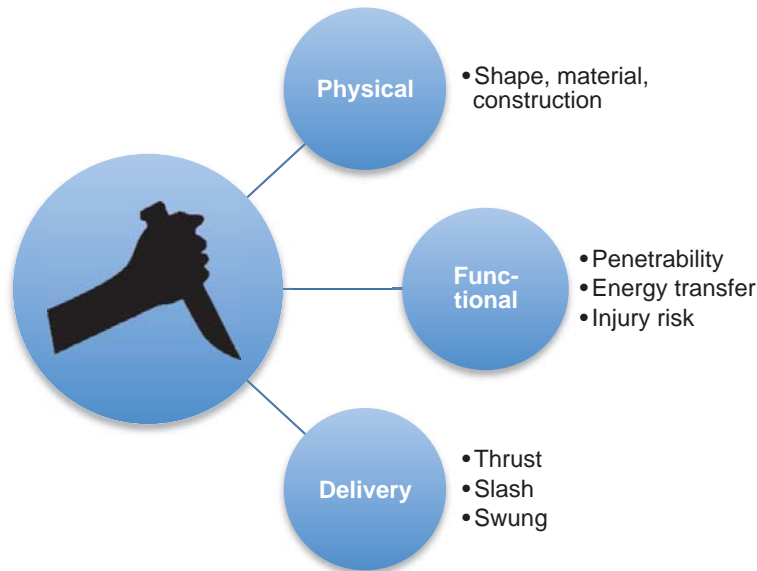

Figure 8: Initial stab weapon descriptive groupings.

The second grouping contains the functional or performance attributes of the weapon. These are based on the measures of performance, specifically, the ability of the weapon to penetrate armour causing bodily injury. The exact parameters will depend on the mechanisms involved in each process such as tip sharpness, material strength, and energy transfer. While there is some overlap with the physical attributes, the intent is to identify those responsible for performance. An initial listing of these attributes was presented in Table 7.

The third grouping is the delivery mode of the weapon as there are many ways to administer a fatal blow with the same weapon. For the purpose of this study, only stab or thrust modes of delivery were considered and further cataloguing of information was not carried out.

The general scientific approach to establish weapon taxonomy would be to characterize the empirical relationships of various weapon attributes against performance and develop inter-relationships among these in a statistical sense. The challenge in the current weapon taxonomy effort is the lack of available weapons for empirical investigations and sole dependency on their descriptive attributes such as geometry, materials and intended modes of use. As such, a method is required to evaluate the attributes of the weapon with the objective of being able to predict its performance. Further challenges are evident with the wide variety of data forms including textual, numerical and ordinal types.

A Multiple Criteria Decision Making (MCDM) process was used to consolidate and rank the weapon information. In principle, a weighted objective function is defined based on fundamental weapon attributes that contribute to its performance. It has the form:

$$Objective = \sum_{i=1}^n W_i(C_i) \quad \text{Eqn (1)}$$

where:

C = the objective criteria,

W = the weighting factor,

N = the number of criteria.

In essence, each criteria, whether it be a descriptor of an attribute or assessment of performance, is prioritized in accordance to their contribution to performance. The sum of all the prioritized criteria then reflects the overall performance of the weapon. When completed for each weapon, the values can be ranked and grouped to identify those with the propensity to perform more

effectively. It is recognized that this is an approximation of the weapons true performance but until experimentation can be conducted with a small set of down selected weapons this is considered an acceptable means to rank the information.

Establishing the priorities or weighting factors for the criteria based solely on descriptive information is problematic as qualitative and quantitative information is used. To address this, a subset of the MCDM process called the Analytic Hierarchy Process (AHP) is used [Saaty and Vargas 2006]. The AHP allows for consistent ranking of seemingly disparate criteria. It involves creating relative linear or non-linear rankings of paired criteria comparisons while providing an assessment of consistency between the rankings. Further, it can be applied to multilevel hierarchic structures where multiple objective functions are used, typically from low level to more global assessments.

In the context of the weapon taxonomy, the highest level would be associated with its injury performance while sublevels would be associated with specific attributes that contribute to this performance. An example of the hierarchy is presented in Figure 9 listing the overall weapon performance as the high level objective but which in turn is based on lower level weapon assessments of weapon attributes and their descriptors.

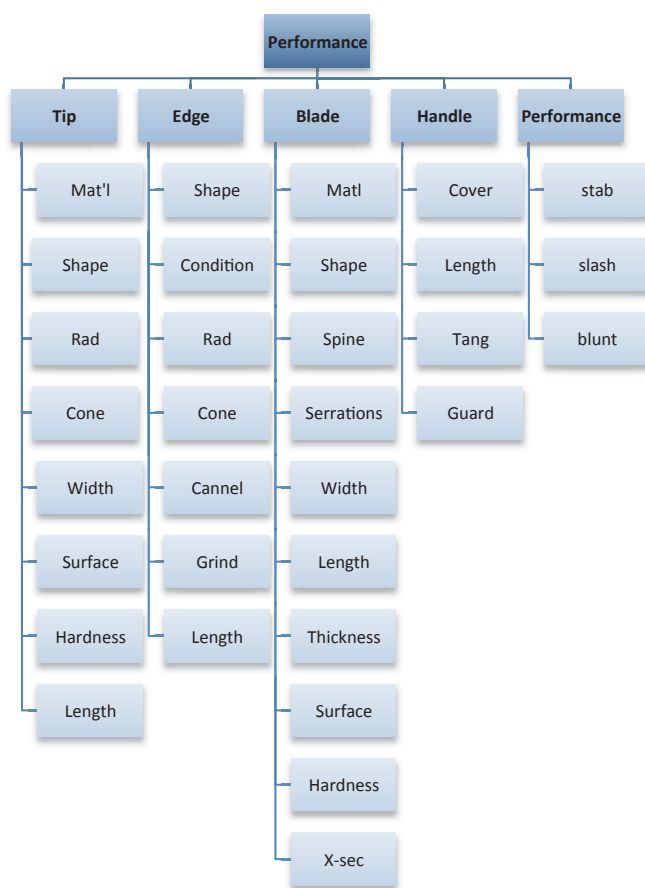

Figure 9: Weapon performance assessment with a hierarchal structure of attributes.

The structure of the weapon data for the AHP criteria used in the study is presented in Table 8. The attributes defined in the table are consistent with those identified in the literature (Section 1.5) and the initial database typology (Section 2.2, Table 7).

Table 8: Weapon attributes and system level ranking scheme.

Description	Function	Attributes	Comments
Attribute:			
Tip Feature	Perforation	Tip Material	Materials with greater compressive modulus over aramids ranked higher. Steel=200, Aramid=60-120, Glass=50-90, Al=69, Wood=9-11, Plastic hard=2-4 GPa
		Tip Cone	Sharper angles increase penetrability of weapon
		Tip Width, Dia. Tip Length	Related to cone angle Related to cone angle and maximum penetration possible
Edge Feature	Cutting	No. Edges	Greater number of cutting edges will improve armour perforation through fiber cutting.
		Edge Condition	Sharper edges will lead to less resistance during perforation due to either cutting or fiber dispersion action.
		Edge Material	See tip material
Blade Feature	Force delivery	Blade Width	Greater cross sectional area increase effort and improves weapon integrity
		Spike Dia.	
		Blade Material	Stronger materials more capable of higher loads
		Weapon Length	Long weapons may decrease buckling and stability of weapon
		Handle Length	Affects retention of weapon and load transfer
System:			
Tip	Penetrability	Tip Value	AHP method of determination
Edge		Edge Value	AHP method of determination
Blade		Blade Value	AHP method of determination

The upper or system level AHP criteria referred to at the bottom of the table take into account weighted contributions from the tip, edge and blade of the weapon. Similarly, the effectiveness of the tip, for example, is based on the weighted contributions of the tip perforation performance, which in turn is based on the weighted contributions of material, cone angle, diameter/thickness and length. This hierarchical process is applied to the edge and blade as described in the table. Figure 10 presents the process in graphical format where the criteria are identified as Tip Value (TV), Edge Value (EV), and Blade Value (BV). The criteria are defined below but are noted to use information directly from the topology database and data from performance estimates based on a combination of database entries. The weighting factors are denoted by the lower case letters, which are determined for each application level of the AHP.

Weapon Value $WV = a(TV) + b(BV) + c(EV)$	Eqn. (2)
--	----------

where:

- WV = the system level assessment of the weapon performance,
- TV = Tip Value, performance assessment of the tip,
- BV = Blade Value, performance assessment of the blade,
- EV = Edge Value, performance assessment of the edge,
- a, b, c = weighting factors determined from the AHP.

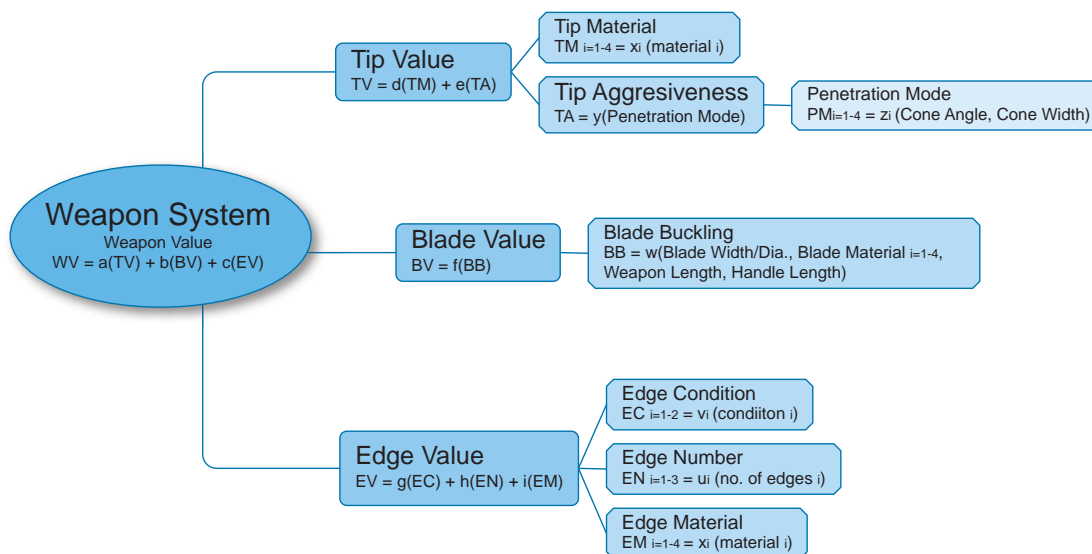

Figure 10: Weapon system ranking scheme incorporating tip, edge and blade attributes.

The weighting values are determined through the AHP where expert opinion is provided in terms of relative weightings between matched pairs of criteria. The calculations are provided in the weapon typology database worksheet provided under separate attachment.

For the weapon system assessment, the weightings are provided in Table 9 which indicates that the tip value criteria has the greatest contribution to weapon performance followed by the blade and edge. Total weightings are normalized to a value of one by way of the AHP.

Table 9: Weapon Value weightings.

Criteria	Weightings	
TV - Tip Value	a	0.78
EV - Edge Value	b	0.07
BV - Blade Value	c	0.15
	Total	1.00

The Tip Value is based on the formula below:

Tip Value $TV = D \cdot d(TM) + E \cdot e(TA)$	Eqn.(3)
---	---------

where:

- TV = Tip Value, performance assessment of the tip,
- TM = Tip Material, performance assessment of the tip material,
- TA = Tip Aggressiveness, performance assessment of the tip geometry,
- d, e = weighting factors determined from the AHP for TM and TA,
- D, E = weighting factors for the relative importance of TM and TA.

The weighting values are determined from the AHP and are presented in Table 10, Table 11 and Table 12. The tip material rankings are based on the relative ratios of compressive modulus while the tip aggressiveness values are based on rudimentary penetration models.

There were four modes of penetration depending on the geometry of the weapon as determined by the tip condition (pointed, blunt) and by the tip geometry (conical, chiselled). For pointed weapons, the mode of penetration is assumed to be one of fibre separation and the cross-

sectional area of the weapon presented at maximum allowable penetration (7 mm, ignoring armour thickness) is used to relate to the resisting forces. For blunt weapons, a shear failure mode is assumed and the width or diameter is ranked to relate to the number of fibres involved in shear failure. In all cases, frictional forces and dynamic effects are ignored due to the lack of data in the initial typology database.

Table 10: Tip Value weightings.

Criteria	Weightings	
Tip Material (TM)	D	0.50
Tip Aggressiveness (TA)	E	0.50

Table 11: Tip Material weightings.

Criteria	Weightings	
wood	1	0.04
metal	2	0.58
glass	3	0.30
plastic	4	0.07
Total		1.00

Table 12: Tip Aggressiveness weightings.

Criteria	Weightings	
Mode I - Pen Force Cone Tip	1	0.53
Mode I - Pen Force Chisel Tip	2	0.31
Mode II - Blunt Force Circ Xsec	3	0.10
Mode II - Blunt Force Sqr Xsec	4	0.06
Total		1.00

A mapping of the maximum AHP rankings can be assessed by exploiting the possible data entries as seen in Table 13 and graphically in Figure 11. It can be seen that a higher weighting is given for weapons made of metal with pointed conical tips and that a lesser weighting is provided for wood weapons having a rectangular cross section.

Table 13: Range of Tip Values based on TM and TA.

Desc	wood	metal	glass	plastic
Mode I - Pen Force Cone Tip	0.29	0.56	0.42	0.30
Mode I - Pen Force Chisel Tip	0.18	0.45	0.31	0.19
Mode II - Blunt Force Circ Xsec	0.07	0.34	0.20	0.08
Mode II - Blunt Force Sqr Xsec	0.05	0.32	0.18	0.07

Note: Full normalized criteria values of 1 used for demonstration purposes.

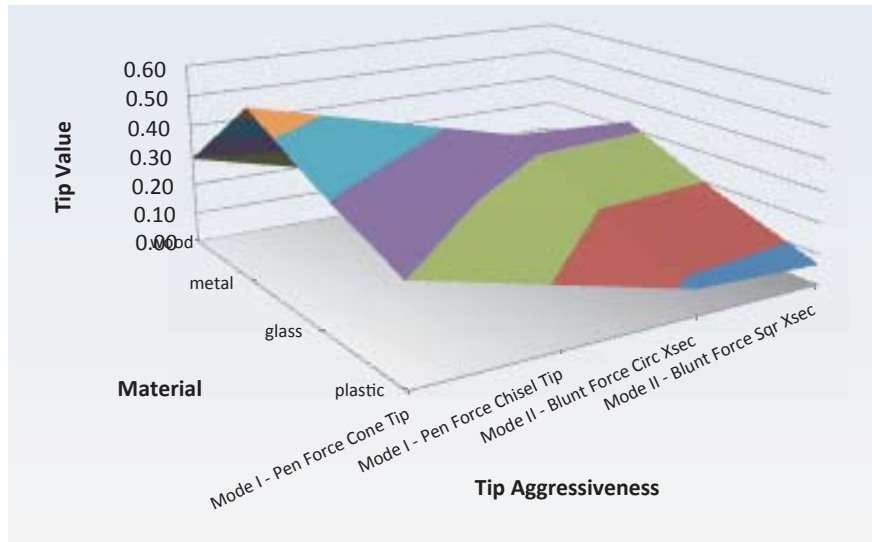

Figure 11: Tip Value topography based on weapon penetrability and material.

The AHP method was applied to the blade utilizing a blade buckling function as the means to establish the weighting values. The blade buckling was based on Euler's critical buckling load calculation for pinned-pinned end conditions under the assumption that the handle constraint by the hand is relatively weak in rotation and that the fabric armour traps the tip. The buckling assessment also incorporates the Young's Modulus of the blade material and is therefore not explicitly included in the AHP as done for the Tip Value. The Blade Buckling loads are normalized to obtain a maximum weighting of 1.

Blade Value $BV = F \cdot f(BB)$	Eqn.(4)
---	---------

where:

- BV = Blade Value, performance assessment of the blade,
- BB = Blade Buckling, buckling performance assessment,
- F, f = weighting factors for the BB assessment.

The Edge Value is based on the formula below:

Edge Value $EV = G \cdot g(EC) + H \cdot h(EN) + I \cdot i(EM)$	Eqn.(5)
--	---------

where:

- EV = Edge Value, performance assessment of the edge,
- EC = Edge Condition, the qualitative sharpness of the edge,
- EN = Edge Number, performance assessment of the no. edges,
- EM = Edge Material, performance assessment of the edge material,
- g, h, i = weighting factors determined from the AHP,
- G, H, I = weighting factors for the relative importance of EC, EN, EM.

The weighting values are determined from the AHP and are presented in Table 14, Table 15, Table 16 and Table 17. The Edge Condition is based on the qualitative descriptor of the edge sharpness while the Edge Number is a count of the number of sharp edges. The edge material rankings are based on the relative ratios of compressive modulus. A mapping of the Edge Value for two parameters can be seen in Figure 12

Table 14: Edge Value weightings.

Criteria	Weightings	
Edge Condition (EC)	G	0.26
No. Edges (EN)	H	0.41
Edge Material (EM)	I	0.33

Table 15: Edge Condition weightings.

Criteria	Weightings	
sharp	1	0.83
blunt	2	0.17

Table 16: Edge Number weightings.

Criteria	Weightings	
0	1	0.16
1	2	0.30
2	3	0.54

Table 17: Edge Material weightings.

Criteria	Weightings	
wood	1	0.04
metal	2	0.58
glass	3	0.30
plastic	4	0.07

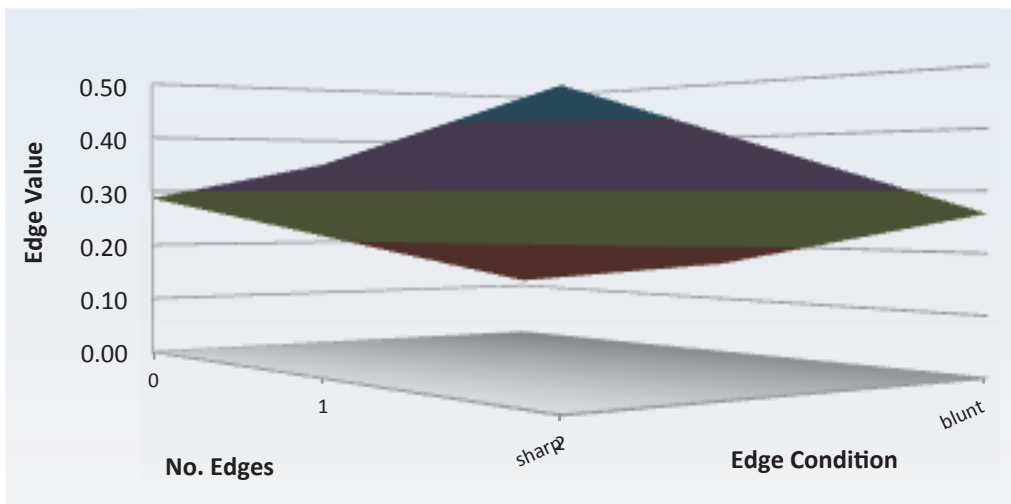

Figure 12: Edge Value topography based on edge condition and quantity.

3.6 Descriptive Taxonomy Results

The AHP process was used to develop an overall ranking of the weapons performance as a system including the contributions from the tip, edge and blade. Descriptive data from the weapon survey and predictive performance functions were used in the process and applied to specific weapon types identified at the start of the study. The results of the assessments can be seen in Figure 13 for the bladed weapons, Figure 14 for spiked weapons and Figure 15 for the stakes. Stake data was limited and computation of the full Weapon Value was not possible.

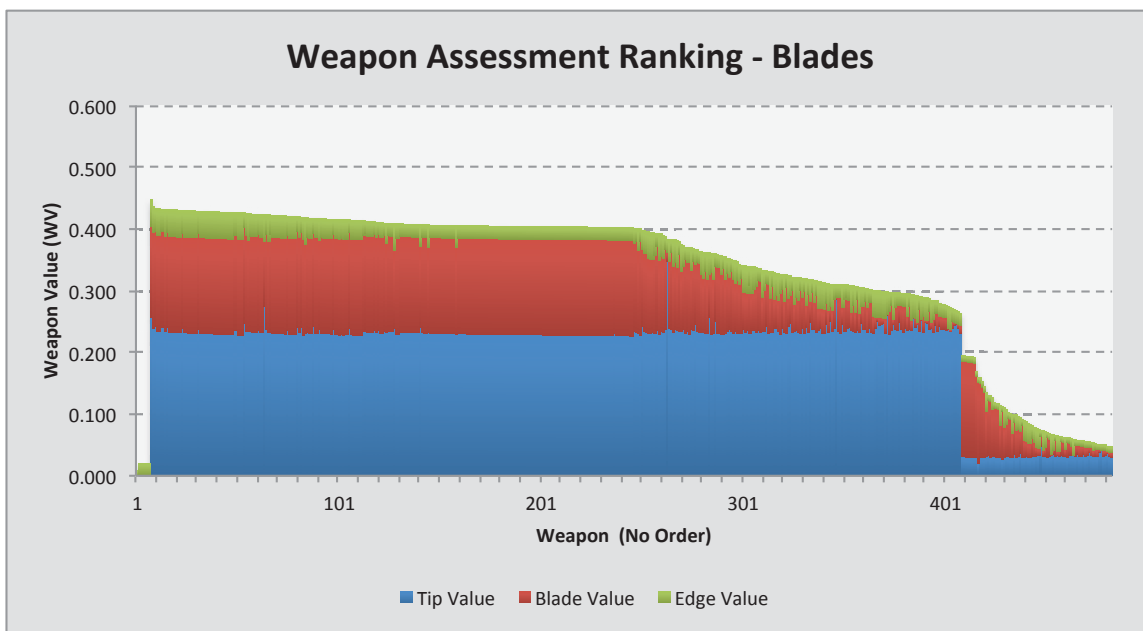

Figure 13: Weapon value rankings for bladed styles.

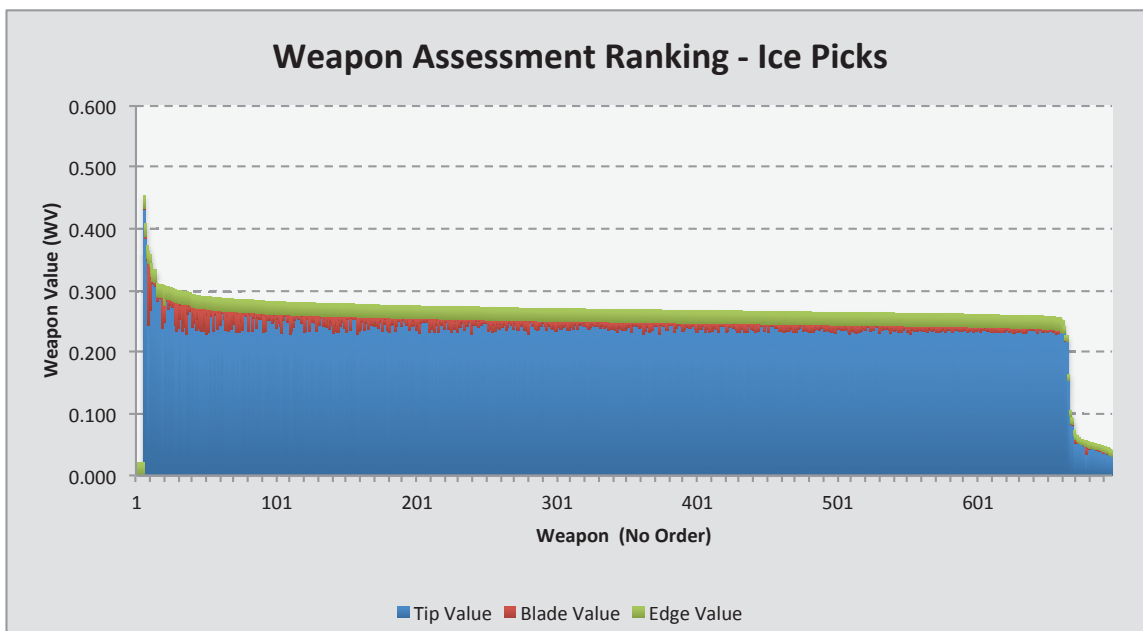

Figure 14: Weapon value rankings for spiked styles.

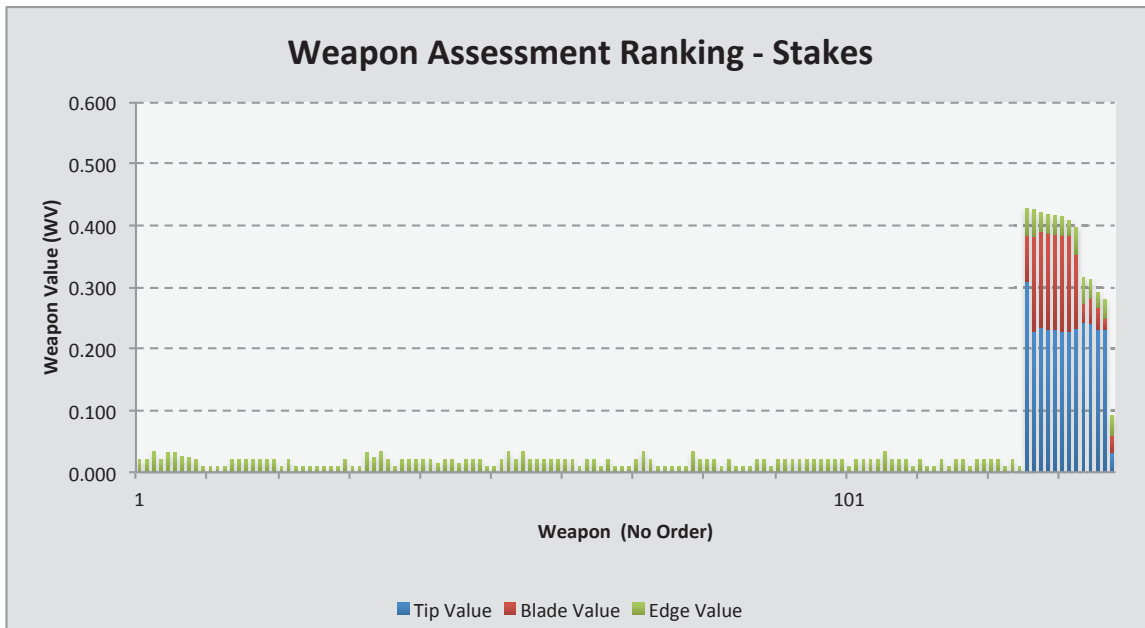

Figure 15: Weapon value rankings for stake styles.

The relative contribution of the tip, edge and blade to the overall ranking can be seen for each weapon. A high Weapon Value corresponds to a predicted aggressiveness of the weapon in terms of its penetrability. It should be noted that many of the rankings are based on coarse descriptions of the weapons due to the absence of empirical data or performance relationships. As a result, the rankings are also coarse but provide sufficient specificity to identify marginally performing weapons and those that are outliers, good or bad.

4. Weapon Down-Selection

The objective of the initial weapon typology was to develop a hierarchical ranking of the weapons based on their specific characteristics and projected performance with armour systems. A smaller group of higher performing weapons could then be identified and their characteristics further detailed and quantified.

A down-selection process was carried out by ranking the overall Weapon Value and hence, performance, by each weapon type (i.e. blade, ice-pick, stake, slash). The upper quintile of high-ranking weapons was typically selected for further detailed characterization. In cases where there were insufficient weapons, either the upper quartile was selected or supplemented with additional lower ranking weapons if the sample size was deemed too small. A sample size of 25 weapons was targeted with actual selections found in the weapon database.

The resulting down selected weapon assessment values are provided in Figure 16 by weapon style.

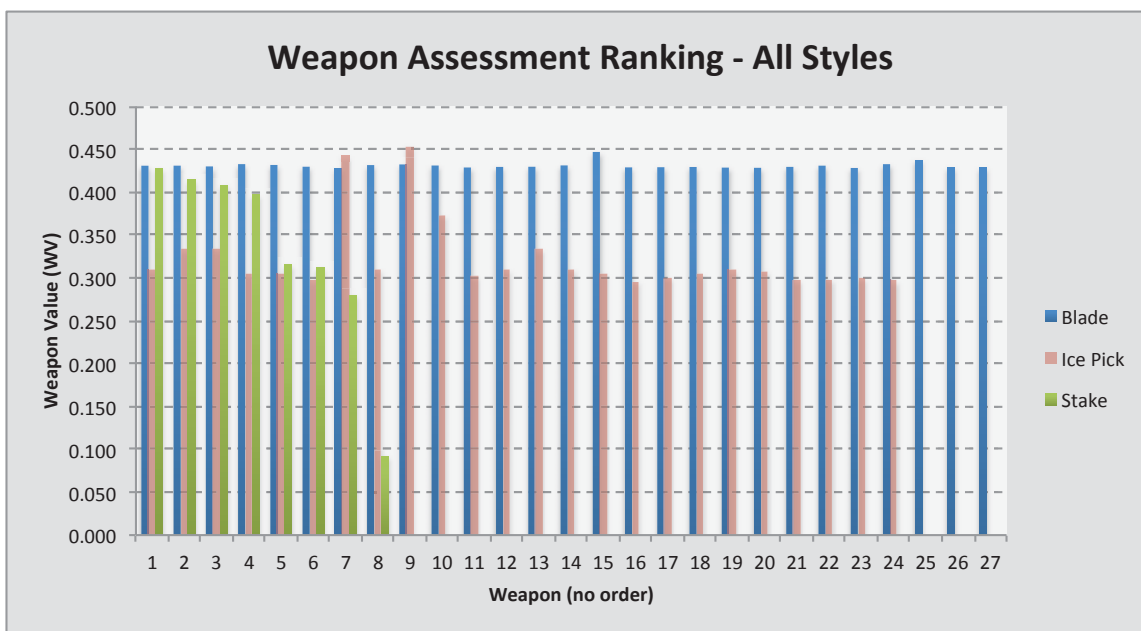

Figure 16: Weapon Value rankings of the down selected group based on descriptive typology.

5. Taxonomy – Performance Based

5.1 Weapon Characterization Requirements

Upon completion of the initial descriptive typology and down selection efforts described in Section 4, a higher degree of detail was required on weapon performance and geometry for development of the exemplars. Ideally, the geometric details of the weapon can also be used to characterize weapon performance such as the tip radius, tip cone angle, edge radius, edge profile, blade strength, blade stiffness and material strength. However, due to the imprecise manner in which the weapons are fabricated and the difficulty in obtaining extremely precise measures of radii and included angles, an alternate approach was used in which an appropriate performance test of the tip, edge and blade would be administered to the down selected weapons. This method is consistent with the NIJ and HOSDB standards for assessing tip sharpness, for example. The performance tests were expanded to include push-through performance, tip sharpness, edge sharpness, blade hardness and flexural stiffness. Details of the tests are provided in the following sections.

The sample size for the weapon performance tests is provided in Table 18. The numbers differ from the down selection sample size due to weapon breakage or deterioration when executing the tests or due to data artefacts or non-representative weapon construction.

Table 18: Weapon down selection sample sizes and performance tests.

Style	Performance	Tip	Edge Sharpness	Blade Hardness	Flexural Stiffness
Bladed	30	26	25	26	9
Ice-pick	25	21	0	13	2
Stake	11	7	1	6	0
TOTAL	66	54	26	45	11

5.2 Tip Sharpness Test Methodology

The most current methods for tip and edge sharpness evaluations have been proposed in the HOSDB Spike and Knife Resistance standard and the HOSDB Slash Resistance standard [Malbon and Croft 2006; Croft and Longhurst 2007]. The NIJ 0115.00 stab resistance standard adopted similar tip sharpness test methods. The methods relate the penetrating force to indentation as a means to quantify the degree of sharpness and can therefore be used as a relative ranking method for the weapons surveyed. Absolute ranking will only be possible through dynamic testing of actual or simulated weapons with armour systems.

In the current study, tip sharpness was assessed with a quasi-static test setup similar to the methodology used by the NIJ 0115 and HOSDB standards. The operating principle is based on replacing the indenter of a hardness machine with the tip of the weapon and measuring the resisting force during indentation. Changes were made from the standard methodology in that a constant 3 mm indentation depth was used and the corresponding force measured. This provides constant interaction with the tip and was felt to better represent the interactions with armour systems. Further, the indentation block was changed from pure aluminum to pure lead in order to not damage the softer metals used in the improvised weapons gathered in the study.

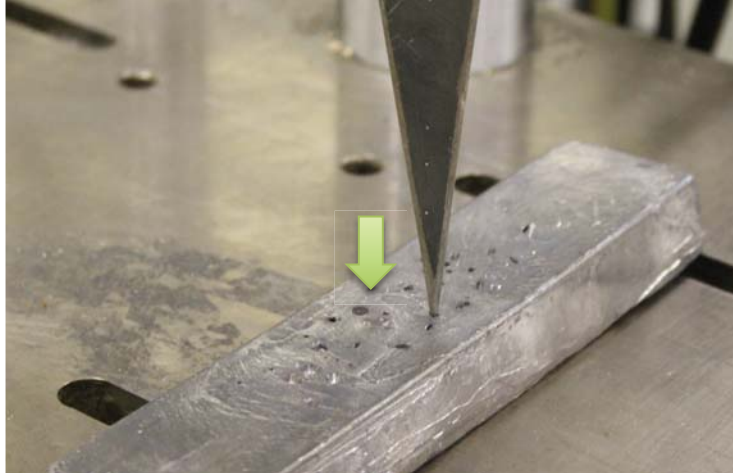

Figure 17: Tip sharpness indenter test setup (courtesy of WSU).

All testing was performed by WSU and the results were entered into the weapon database. A typical response curve is provided in Figure 18. A lower force would correspond to greater tip sharpness.

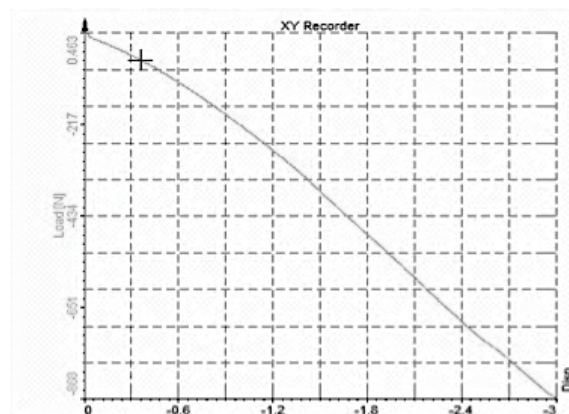

Figure 18: Typical tip resistance force response.

The test results for the down selected samples are provided in Figure 25 and Figure 26 for bladed and spiked weapons, respectively. No stake data is presented as these were removed from further analysis due to the limited sample size and equal or lesser performance compared to the other weapons.

5.3 Edge Sharpness

The edge sharpness test methodology was based on the principles developed by CATRA and proposed by Watson which measure the force required to press the edge of a weapon into a silicone rubber substrate [Watson, Horsfall et al. 2002]. WSU implemented the test hardware, instrumentation and carried out all data collection.

For the current study, measuring the force required to press the edge of the blade into a silicone strip of constant width at a given depth assessed the initial edge sharpness. The tip was aligned with the front edge of the silicone rubber and the edge was parallel to the surface. The portion of blade edge interacting with the silicone was controlled by the width of the rubber strip. The

rubber strip is wrapped around a rod to provide some surface tension as the edge cuts through the surface, thereby reducing interaction with the sides of the blade and reducing frictional effects, as intended by the CATRA test methods. The above method provides an approximation of the edge sharpness although dynamic effects are ignored, as are potentially different edge interactions with various armour systems (i.e. fabric, chainmail, metal/ceramic plates).

The results of the tests are provided in Figure 25 and Figure 26 for bladed and spiked weapons, respectively. Again, no stake data is presented for the same reasons stated in the tip sharpness tests. The data was reviewed and artefacts noted.

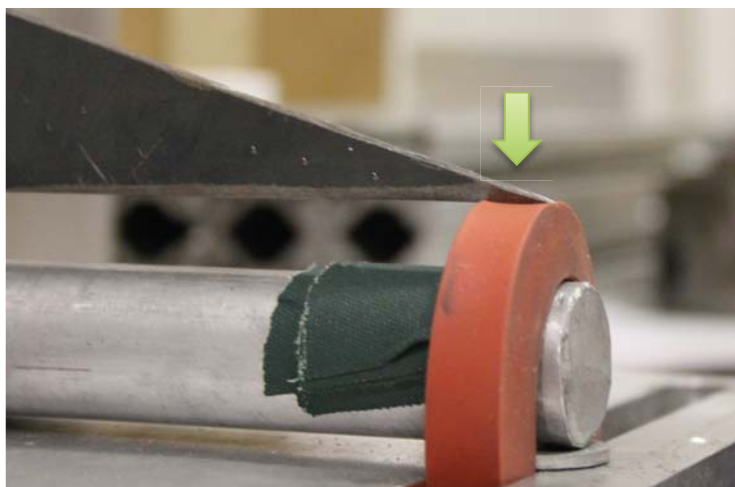

Figure 19: Edge sharpness test setup (courtesy of WSU).

5.4 Weapon Hardness

5.4.1 Background

Knowledge of the weapon's blade material strength is important to provide an assessment of the tip, edge and blade integrity. Weapon material strength can be inferred from its hardness as this is commonly used as an indicator of the strength of material, or more specifically, the yield strength.

A standard Rockwell indenter test method was employed and executed by WSU. The Rockwell "B" scale was used as it is well suited for use with soft metals such as steel, aluminum and brass. Due to the small size of the indenter it provides local hardness measurements and is less susceptible to surface flatness deviations.

For comparative purposes, a Rockwell "B" scale value of 120 is equivalent to a Rockwell "C" scale value of 55, i.e. similar to that of the current NIJ 0115.00 "P1/A and "S1/G" stab threats.

5.4.2 Methods

The hardness test method employs a Rockwell tester to apply a standard preload to the indenter followed by a major load (100 kg) after which the depth of indentation is measured and the hardness number determined, see Figure 20. It uses a 1.59 mm steel sphere as the indenter.

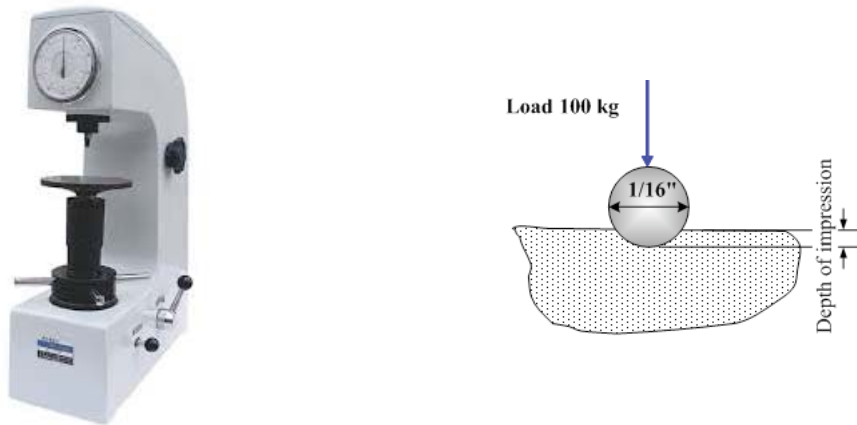

Figure 20: A typical Rockwell hardness tester and; Rockwell “B” spherical ball indenter.

The accuracy of the hardness measurements depends on the surface condition of the test sample. Surface curvatures should be large the irregularities small relative to the size of the indenter for best results.

5.4.3 Results

The surface hardness of the selected weapons was measured with the Rockwell test method. Sample preparation by surface grinding for flatness and irregularities was not done. Weapons with very small curvatures, such as the small diameter ice picks, could not be measured with this method and no data was collected.

Accuracy of the apparatus was confirmed at regular intervals with a steel calibration block and no discrepancies were noted throughout the test series.

The test results are contained within the weapon database and are presented graphically in Figure 25 and Figure 26 for bladed and spiked weapons, respectively.

5.5 Push-through Tests

5.5.1 Background

A method was sought to assess the overall weapon system performance incorporating the tip, edge, and blade but in a simple manner compared to the NIJ0115.00 test protocol due to the non-standard construction methods and relative frailty of the weapons.

An initial trial at WSU, incorporating layers of clamped fabric armour and measuring the force required to push the weapon through the layers, was deemed sensitive enough to segregate the higher performing weapons. This method was later refined and used to assess the performance of the down-selected weapons as described below.

The use of simple quasi-static test methods to assess weapon performance is not new and forms the basis for many sharpness test methods proposed by CATRA and others. In fact, the tip and edge sharpness tests reported on earlier, are also quasi-static in nature and provide quantitative measure of performance. The peak force obtained during the push-through tests was purported to correlate well with dynamic drop tests of the NIJ 0115.00 in discussions with body armour industry representatives. The American Society for Testing and Materials (ASTM) also has several methods for assessing fabric cutting and puncturing utilizing quasi-static loads (ASTM F1790, ASTM F1342) as referenced in NIJ 99-114 for glove performance testing.

5.5.2 Methods

The push-through test method was implemented by WSU and consisted of clamping an armour system in place around its periphery to prevent slippage, Figure 21 and Figure 22. A method was developed to remove slack in the system without pre-tensioning the fabric. In this manner, a weapon can be mounted to an Instron machine and the force-displacement relationship can be measured, hopefully resulting in a similar ranking to the dynamic drop tests.

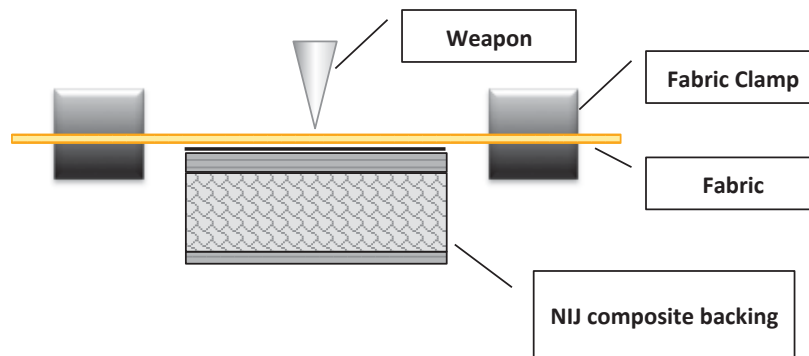

Figure 21: Push-through test components and setup.

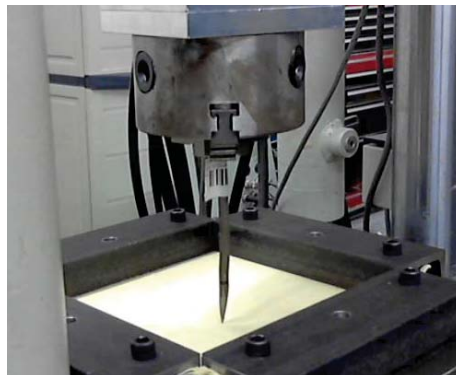

Figure 22: Push-through test setup (courtesy of WSU).

The test metrics included the instantaneous force and displacement of the driving head of the Instron machine, the instantaneous work performed by the weapon, a record of the number of armour fabric layers perforated, the residual penetration and note of the fabric failure mode.

The residual penetration was measured by the number of Neoprene® rubber layers in the NIJ backing pack damaged by the weapon. As a result, penetration was measured in 7 mm intervals. Proposed methods to measure instantaneous penetration were not achieved due to the complexity of the setup required. Attempts to measure the actual level of penetration with the NIJ backing witness paper was not successful due to premature rupturing of the paper during the stroking phase.

The armour material selected for the tests was based on discussions with an armour manufacturer who indicated that the most common armour system was either DuPont's Kevlar® Correctional™, Twaron's Microflex® or SMR 509 aramids, depending on the threats to be defeated. For the current investigation of the correctional weapons, Twaron Microflex® 60" (550

DTEX) Special HS, was chosen. Attempts were made to look at novel armour systems including metal plates, metal fibres woven into aramids and laminated weaves but cooperation from the suppliers was lacking despite high initial interest in the program's objectives.

The number of layers of fabric was chosen by WSU to allow the majority of weapons to marginally perforate the fabric layers as a minimum in order to obtain data on the force and work required to achieve perforation. Selection of a robust armour system preventing perforation would not result in meaningful data about the penetrability of the weapon. A total of 3 layers of Twaron Microflex® was selected for use in the test series.

The test protocol involved placement of the weapon against the clamped armour fabric, placement of the backing material and execution of the test until the test is aborted. Four criteria were used to aborting a test:

1. Weapon failure, fabric slippage, weapon clamp slippage.
2. Perforation in excess of 7 mm (current fail criteria in NIJ 0115.00).
3. Peak perforation force exceeds human capacity [Chadwick, Nicol et al. 1999], 1885 N.
4. The work performed exceeds human energy capacity [Chadwick, Nicol et al. 1999], 62 J.

A draft protocol, measurement method and reporting requirements document was prepared by Biokinetics to guide the test series, Appendix B. All results were entered into the weapon typology database for subsequent analysis.

5.5.3 Results

The force data collected for the down selected blade and spike weapons were provided by WSU and are presented in Figure 23 and Figure 24, respectively. The weapons are ranked by peak force measured during the controlled push-through tests. The corresponding forces required to perforate the first and second of the three layers of armour are also presented as Force L1 and Force L2, respectively. The maximum work/energy expended on conducting the tests is also provided for each weapon.

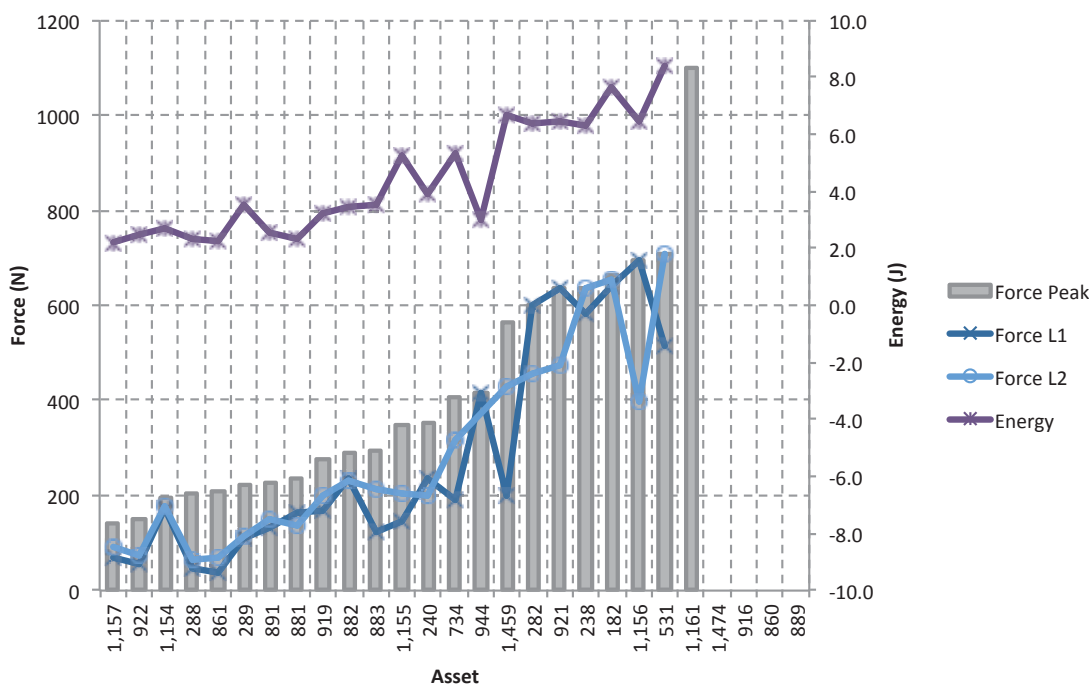

Figure 23: Push-through bladed weapon force test results.

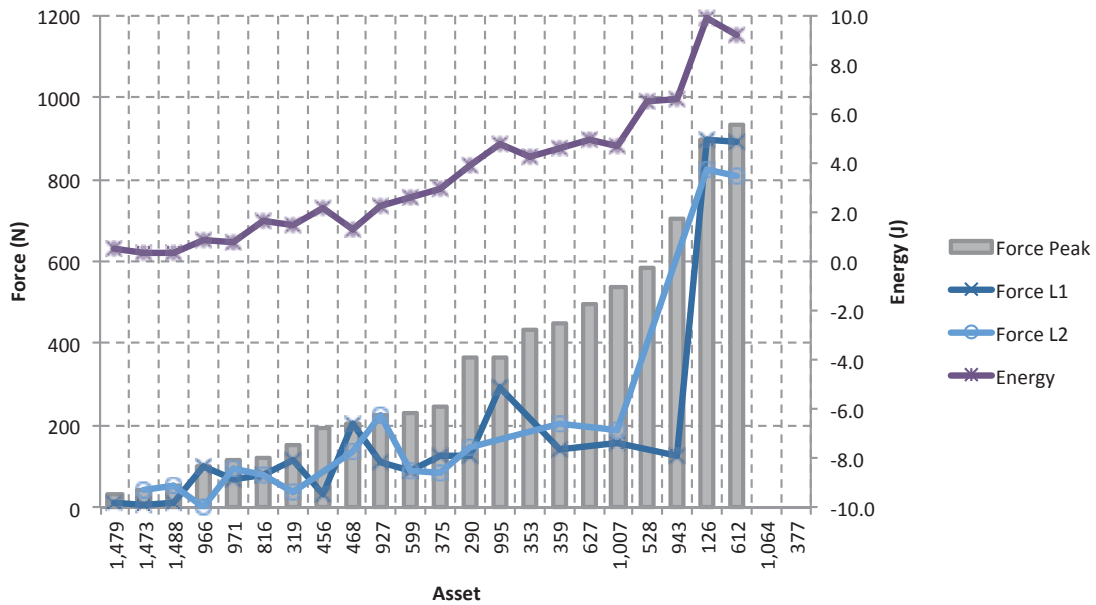

Figure 24: Push-through spiked weapon force test results.

It may be observed that the peak force corresponds well to the perforation forces of individual layers and that the energy also tracks in a similar fashion. These trends are not unexpected and provide a basis for further creating a weapon subset that eliminate relatively dull and underperforming weapons, i.e. where no perforation occurred or where high forces are involved. Further, it was of interest to see whether greater fabric deformation occurred at perforation due to the higher forces involved, however, no correlation between the weapon stroke, energy or peak force was observed.

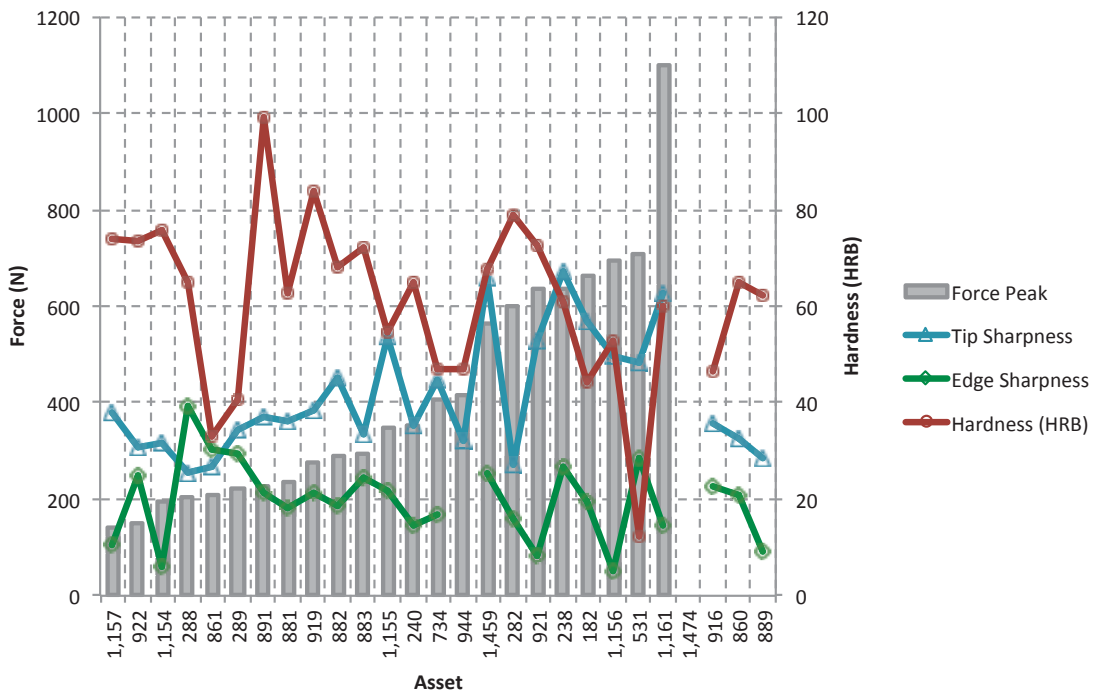

Figure 25: Push-through blade test performance and attributes.

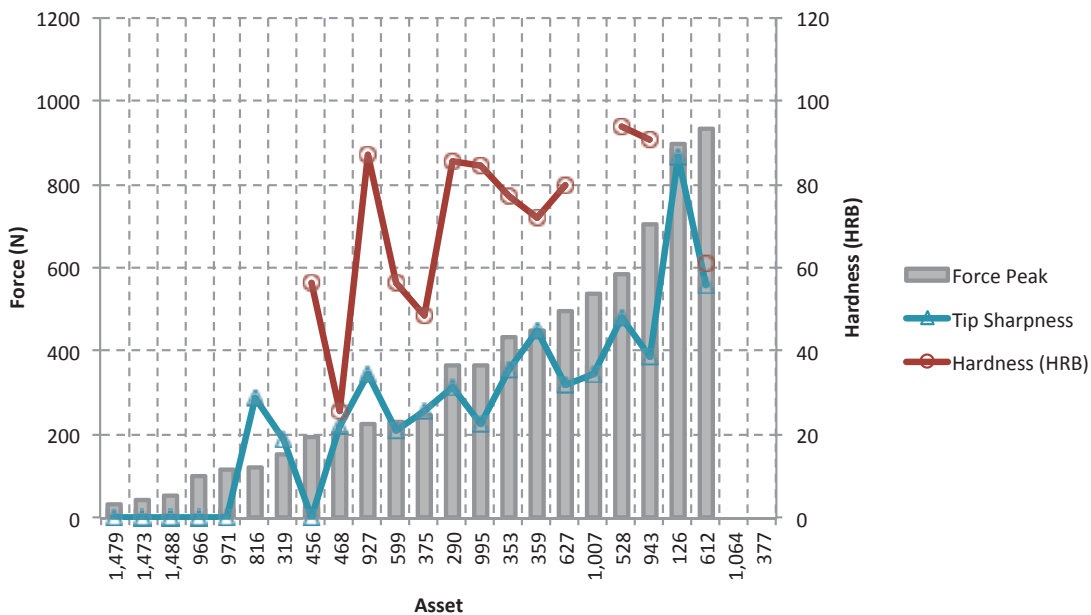

Figure 26: Push-through spike test performance and attributes.

The tip and edge sharpness performance results of the down selected bladed and spiked weapons provided by WSU are presented in Figure 25 and Figure 26, respectively. The weapons are sorted by the peak force values noted earlier. The sharpness values reference the secondary axis and should be read as Newton since the hardness values share the same axis. No spike tip sharpness values were obtained for six weapons due to difficulty in performing the indentation test without significant bending of the weapon body.

The weapons with low peak forces tend to exhibit higher tip sharpness values (lower force) for both the blades and spikes. Edge sharpness for the blades did not correspond to peak force.

Material hardness readings for the blades and spikes presented in the figures vary considerably and may be partly due to material composition, local hardness variations or weapon geometry leading to variable results. The average of three hardness readings was reported by WSU to reduce these variations and has been used in the quoted results.

6. Exemplar Weapon Development

6.1 Basis for Exemplars

The performance based taxonomy efforts reported in Section 5 attempted to characterize the weapon attributes responsible for the perceived interactions and failure modes of the armour systems for subsequent development of the exemplars. It was observed that a subset of these weapons exhibited greater perforation performance and were therefore chosen for additional characterization and grouping as described in the following sections. The additional performance analyses included bending and buckling modes of the blade or body, material selection, geometric definition of the tip, edge and blade and finally, compatibility with the NIJ 0115.00 test setup.

6.2 Geometry

Upon analysis of the geometric and performance data shown in Section 5 a subset of 9 bladed weapons and 9 spiked weapons were chosen for the further development of the exemplars. The purpose of the new subset was to identify weapons and their characteristics that were more aggressive in behaviour. No stakes were chosen due to the small test sample size and overlapping performance with the other weapon types. The selected blades and spikes together represent 1.3% of the weapon survey.

The subset of 9 blade and 9 ice pick weapons are depicted below in Figure 27 and Figure 28, respectively. The respective geometric data is presented in Table 19 and Table 20 as measured during the initial typology exercise.



Figure 27: Subset of bladed weapons used for exemplar design.

Inspection of the bladed weapons showed that two distinctive styles were present; a double-edged symmetrical blade and a single edge single grind. Weapon asset numbers 1157, 922, 1154, 891 and 919 were grouped into the double-edged style while assets 288, 861, 289 and 881 were grouped into the single edged style. The corresponding average, range and standard deviation values for the geometric data are presented in Table 19.



Figure 28: Subset of ice-pick weapons selected for exemplar design.

In a similar fashion, inspection of the spikes revealed two distinct styles, a small diameter short-coned style and a larger diameter, long coned style. Weapon asset numbers 1478, 1473, 1488, 966, and 971 were grouped into the short coned style while assets 816, 319, 456 and 468 were grouped for the long cone style. Average, range and standard deviation values are provided in Table 20.

Table 19: Geometric data for the bladed weapon subset.

Asset	Geometric									
	Tip Cone (deg)	No. Edges	No. Edge Grinds	Edge Angle (deg)	Blade Planar Shape	Blade Width (mm)	Overall Length (mm)	Handle Length (mm)	Blade Length (mm)	Blade Thickness (mm)
1157	31.2	2	2	41.4	sym	18.9	228.4	101.4	127.1	3.10
922	29.8	2	2	72.8	sym	12.5	178.0	80.0	98.0	3.22
1154	32.3	2	2	40.1	sym	18.6	215.0	99.6	115.3	3.39
288	16.8	1	1	37.1	trg	35.1	228.3	105.9	122.4	2.63
861	14.2	1	1	49.8	trg	23.2	222.3	109.4	112.9	3.32
289	27.6	1	1	45.8	trg	36.7	189.8	105.3	84.5	1.96
891	49.3	2	2	87.1	sym	13.0	161.4	80.0	81.4	3.22
881	17.4	1	1	23.9	trg	34.3	192.6	80.0	112.6	2.73
919	26.5	2	2	60.8	sym	16.9	162.6	76.5	86.1	3.02
Blade - Single Edged, Triangular										
Average	19.0	1	1	39	trg	32.3	208.2	100.1	108.1	2.66
Min	14.2	1	1	24		23.2	189.8	80.0	84.5	1.96
Max	27.6	1	1	50		36.7	228.3	109.4	122.4	3.32
SD	5.9	0	0	11		6.2	19.9	13.5	16.4	0.56
Blade - Double Edged, Symmetrical										
Average	33.8	2	2	60	sym	16.0	189.1	87.5	101.6	3.19
Min	26.5	2	2	40		12.5	161.4	76.5	81.4	3.02
Max	49.3	2	2	87		18.9	228.4	101.4	127.1	3.39
SD	8.9	0	0	20		3.0	30.8	12.0	19.3	0.14

Table 20: Geometric data for the spiked weapon subset.

Asset	Geometric				
	Tip Cone (deg)	Overall Length (mm)	Handle Length (mm)	Blade Length (mm)	Spike Dia. (mm)
1479	31.0	187.5	133.6	54.0	1.85
1473	30.5	138.4	111.2	27.1	1.57
1488	32.4	119.9	46.6	73.4	1.56
966	45.8	157.3	81.9	75.4	1.93
971	40.0	156.0	74.3	81.7	1.91
816	19.6	89.1	0.0	89.1	4.00
319	9.4	225.0	199.0	26.0	3.53
456	15.1	200.4	101.4	99.0	3.13
468	8.2	180.0	80.6	99.4	1.82
Ice Pick - Short Taper					
Average	36.0	151.8	89.5	62.3	1.77
Min	30.5	119.9	46.6	27.1	1.56
Max	19.6	225.0	199.0	99.4	4.00
SD	6.7	25.1	33.7	22.2	0.18
Ice Pick - Long Taper					
Average	13.1	173.6	95.2	78.4	3.12
Min	8.2	89.1	0.0	26.0	1.82
Max	19.6	225.0	199.0	99.4	4.00
SD	5.3	59.3	81.8	35.3	0.94

6.3 Buckling Modes

For stab weapons, high lateral and torsional loads were noted in addition to the high axial forces suggesting that the blade and handle designs are important, see Section 1.3.

Due to the improvised nature of the corrections weapons and poor blade and handle design, it will be important to assess the propensity for buckling of the weapon. This can affect the delivery of force to the tip and edge diminishing its overall ability to perforate an armour system.

Assessment of the critical buckling loads was carried out during the initial weapon rankings in the taxonomy effort. The assumption of pivoting constraints at the tip and mid-handle was used and ranked weapons with more slender and longer blades or shaft poorly.

For the current exemplar development efforts, the Euler buckling mode was re-assessed and changed to a free-end constraint at the tip and fully constrained handle under the assumption that the bearer of the weapon can constrain the handle, Figure 29. This configuration also better represented the constrained condition with the NIJ 0115.00 weapon clamp. As a result, the critical loads for buckling with a free end constraint and full handle fixation were estimated assuming that steel was the base material and a constant cross sectional area. See Table 21 and Table 22 for bladed and spiked weapon subsets, respectively.

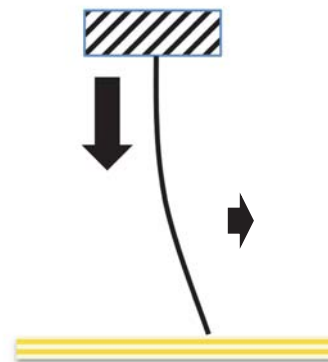

Figure 29: Buckling mode of the weapon with free tip constraint and full handle fixation.

6.4 Flexural Stiffness

In addition to the buckling of the weapon, the amount of force required to displace the tip of the threat laterally was estimated for the bladed and spiked weapon subset. The calculations were based on the flexural stiffness of the weapon with the handle fixed and for a given side load, Figure 30. Steel was chosen as the base metal and a constant cross sectional area was used.

The flexural stiffness estimates are provided in Table 21 and Table 22 for the bladed and spiked weapon subset, respectively. The flexural stiffness values for the blades are similar due to the similar cross sectional geometry while there were distinct differences for the spiked weapons, having greater cross sectional change due to variation in diameters.

Experimental measurement of the actual flexural stiffness of the weapon subset was carried out by WSU. The test setup involved clamping the weapon letting it protrude 65 mm and applying a perpendicular force to the tip of the blade, Figure 31. The stroke of the load applicator rod was limited to 5 mm and a loading rate of 1 mm/s was used. The results of the tests are presented in Table 21 and Table 22. Measurements were not possible for some spikes with the current setup.

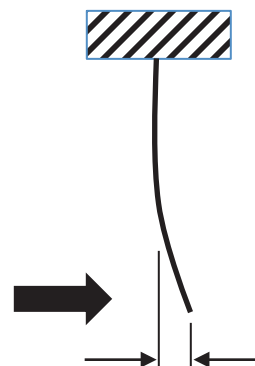

Figure 30: Buckling mode of the weapon with free tip constraint and full handle fixation.

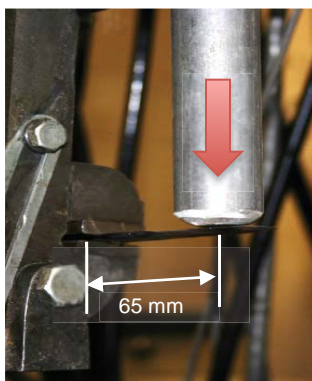

Figure 31: Experimental setup for flexural stiffness (courtesy of WSU).

6.5 Materials

The materials used in the fabrication of the weapons varies significantly as observed from the hardness values, and corresponding yield strength, in Table 21 and Table 22, and shown in Figure 25 and Figure 26, for the bladed and spiked weapon subset, respectively. The blade styles with double and single edges appear to have different hardness values. The spiked weapons also appear to be of variable harnesses, however, there was little data for the selected subset of weapons and therefore an average of the 24 down selected spiked weapons was reported for the short-coned spike.

Table 21: Performance assessments of bladed weapon subset.

Asset	Performance									
	Buckle Load Est. Free (N)	Flexural Stiffness Est. (N/mm)	Flexural Stiffness Act. @65 mm (N/mm)	Force Peak (N)	Plateau Slope L1 (N/mm)	Energy (J)	Perforation (mm)	Tip Sharpness (N)	Edge Sharpness (N)	Hardness (HRB)
1157	1434	14	81	144	26	2.2	18	379	107	74
922	1792	22	55	152	23	2.4	18	308	251	74
1154	2245	24	48	195	16	2.7	25	315	61	76
288	1753	17	39	203	18	2.4	21	255	394	65
861	2730	29	48	211	40	2.3	14	267	302	33
289	1600	23	18	221	27	3.5	25	342	293	41
891	2685	40	83	228	13	2.6	14	372	215	99
881	2262	24	41	234	60	2.3	11	364	180	63
919	2577	36	13	278	41	3.3	18	385	214	84
Blade - Double Edged, Symmetrical										
Average	2147	27	56	200	24	2.6	18.2	352	169	81
Min	1434	14	13	144	13	2.2	14.0	308	61	74
Max	2685	40	83	278	41	3.3	24.5	385	251	99
SD	529	11	29	56	11	0.4	3.8	37	81	11
Exemplar (T2)	2324	27	#N/A	#N/A	#N/A	#N/A	#N/A	#N/A	#N/A	80
Blade - Single Edged, Triangular										
Average	2086	24	37	217	36	2.6	17.5	307	292	50
Min	1600	17	18	203	18	2.3	10.5	255	180	33
Max	2730	29	48	234	60	3.5	24.5	364	394	65
SD	514	5	13	14	18	0.6	6.4	54	88	16
Exemplar (T1)	1879	24	#N/A	#N/A	#N/A	#N/A	#N/A	#N/A	#N/A	55

Table 22: Performance assessments of spiked weapon subset.

Asset	Performance								
	Buckle Load Est. Free (N)	Flexural Stiffness Est. (N/mm)	Flexural Stiffness Act. @65 mm (N/mm)	Force Peak (N)	Plateau Slope L1 (N/mm)	Energy (J)	Perforation (mm)	Tip Sharpness (N)	Hardness (HRB)
1479	97	2.2	#N/A	32	#N/A	0.5	14	#N/A	#N/A
1473	202	9.1	#N/A	46	9	0.3	21	#N/A	#N/A
1488	27	0.4	#N/A	53	12	0.4	14	#N/A	#N/A
966	60	1.0	#N/A	101	#N/A	0.9	21	#N/A	#N/A
971	48	0.7	#N/A	116	8	0.8	14	#N/A	#N/A
816	781	10.6	#N/A	124	35	1.7	7	287	#N/A
319	#N/A	#N/A	17	155	58	1.5	14	190	#N/A
456	238	2.9	3	192	#N/A	2.2	21	#N/A	56
468	27	0.3	#N/A	206	58	1.3	21	222	26
Ice Pick - Short Taper									
Average	87	2.7	#N/A	70	10	0.6	16.8	#N/A	70.6
Min	27	0.4	#N/A	32	8	0.3	14.0	#N/A	#N/A
Max	781	10.6	17	206	58	2.2	21.0	286.6	#N/A
SD	69	3.6	#N/A	37	2	0	4	#N/A	#N/A
Exemplar (T3)	191	2.7	#N/A	#N/A	#N/A	#N/A	#N/A	#N/A	68
Ice Pick - Long Taper									
Average	348	4.6	10	169	50	2	16	233	41
Min	27	0.3	3	124	35	1	7	190	26
Max	781	10.6	17	206	58	2	21	287	56
SD	389	5.4	9	37	14	0	7	49	22
Exemplar (T4)	344	4.9	#N/A	#N/A	#N/A	#N/A	#N/A	#N/A	68

6.6 Exemplar Design

Development of the exemplar threats reflected the geometric and performance characteristics of the weapon subsets described by the averaged geometry of each style (Table 19 and Table 20) with adjustments made to the cross section at the clamped end to achieve similar buckling and flexural modes (Table 21 and Table 22). Additional measurements of the blade grind depths were made from photographic data to determine the included angle of the edges. Since tip and edge radii could not be established from the surveyed weapon data measurements, the quasi-static performance data was relied upon for confirming the performance of the exemplars.

Four different exemplar threats were developed to represent the surveyed weapon styles:

Exemplar Designation	Description
T1	Blade: single edged, single grind, asymmetrically tapered with rectangular blade cross section.
T2	Blade: double edged, double grind, symmetrically tapered with rectangular blade cross section.
T3	Spike: small diameter rod, short tapered tip.
T4	Spike: medium diameter rod, long tapered tip.

An attempt was also made for the exemplars to be compatible with the NIJ threat holder and length of the legacy threats, to the extent possible. Due to the flexural requirements, the lengths of the two blade styles had to be extended beyond the standard 101 mm length and will require

adjustment of the test table height to maintain the stipulate distances for velocity measurement of the falling threats. The bladed exemplars can still be used with the existing NIJ 0115.00 weapon clamps. Furthermore, the spiked exemplar holder will require modifications due to the different diameters specified.

The exemplar geometric specifications are presented in Table 23 and Table 24, for the bladed and spiked exemplars, respectively. Varying degrees of tip and edge sharpness were investigated for each exemplar type in an attempt to determine the most representative attributes.

Table 23: Geometric data for the bladed exemplars.

Asset	Geometric											
	Tip Cone (deg)	Tip Flat (in)	No. Edges	No. Edge Grinds	Edge Angle (deg)	Edge Flat (in)	Blade Planar Shape	Blade Width (mm)	Overall Length (mm)	Handle Length (mm)	Blade Length (mm)	Blade Thickness (mm)
Exemplar (T1)	20.0	#N/A	1	1	40.0	#N/A	trg	19.8	113.0	17.0	96.0	2.77
T1C	20.0	0.000	1	1	40.0	0.000	trg	19.8	113.0	17.0	96.0	2.77
T1C-1	20.0	0.005	1	1	40.0	0.005	trg	19.8	113.0	17.0	96.0	2.77
T1C-2	20.0	0.015	1	1	40.0	0.015	trg	19.8	113.0	17.0	96.0	2.77
T1C-3	20.0	0.025	1	1	40.0	0.025	trg	19.8	113.0	17.0	96.0	2.77
T1C-4	20.0	0.035	1	1	40.0	0.035	trg	19.8	113.0	17.0	96.0	2.77
T1C-5	20.0	0.050	1	1	40.0	0.050	trg	19.8	113.0	17.0	96.0	2.77
T1Db	20.0	0.035	1	1	40.0	0.025	trg	19.8	113.0	17.0	96.0	2.77
Exemplar (T2)	30.0	#N/A	2	2	60	#N/A	sym	19.8	123.0	17.0	106.0	3.18
T2C	30.0	0.000	2	2	60	0.000	sym	19.8	123.0	17.0	106.0	3.18
T2C-1	30.0	0.005	2	2	60	0.005	sym	19.8	123.0	17.0	106.0	3.18
T2C-2	30.0	0.010	2	2	60	0.010	sym	19.8	123.0	17.0	106.0	3.18
T2C-3	30.0	0.015	2	2	60	0.015	sym	19.8	123.0	17.0	106.0	3.18
T2C-4	30.0	0.020	2	2	60	0.020	sym	19.8	123.0	17.0	106.0	3.18
T2C-5	30.0	0.035	2	2	60	0.035	sym	19.8	123.0	17.0	106.0	3.18
T2Db	30.0	0.020	2	2	60	0.002	sym	19.8	123.0	17.0	106.0	3.18

Table 24: Geometric data for the spiked exemplars.

Asset	Geometric		Overall Length (mm)	Handle Length (mm)	Blade Length (mm)	Spike Dia. (mm)
	Tip Cone (deg)	Tip Flat (in)				
Exemplar (T3)	35.0	#N/A	101.6	17.0	84.6	2.74
T3D	35.0	0.000	101.6	17.0	84.6	2.74
T3D-1	35.0	0.010	101.6	17.0	84.6	2.74
T3D-2	35.0	0.020	101.6	17.0	84.6	2.74
T3D-3	35.0	0.030	101.6	17.0	84.6	2.74
T3D-4	35.0	0.040	101.6	17.0	84.6	2.74
Exemplar (T4)	12.5	#N/A	101.6	17.0	84.6	3.18
T4C	12.5	0.000	101.6	17.0	84.6	3.18
T4C-1	12.5	0.050	101.6	17.0	84.6	3.18
T4C-2	12.5	0.010	101.6	17.0	84.6	3.18
T4C-3	12.5	0.150	101.6	17.0	84.6	3.18
T4C-4	12.5	0.200	101.6	17.0	84.6	3.18

The bladed and spiked exemplar styles are depicted in Figure 32 through to Figure 35. Engineering drawings can be found in Appendix D. Material selections have been proposed to achieve the correct hardness values, however, confirmation with the eventual weapon manufacturer is required.

Final specification of the tip and edge sharpness of the exemplars is required to best approximate the performance of the surveyed weapon subset. This is to be accomplished through quasi-static evaluations using the tip and edge indentation tests as well as the push-through tests.

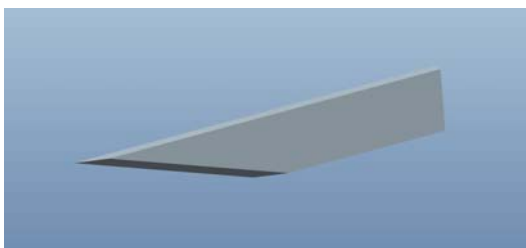

Figure 32: Blade exemplar T1.

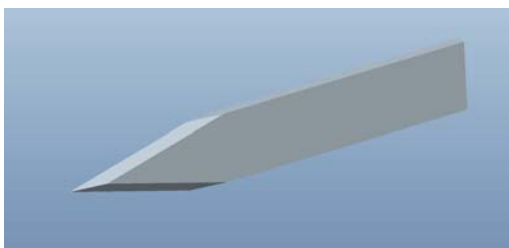

Figure 33: Blade exemplar T2.

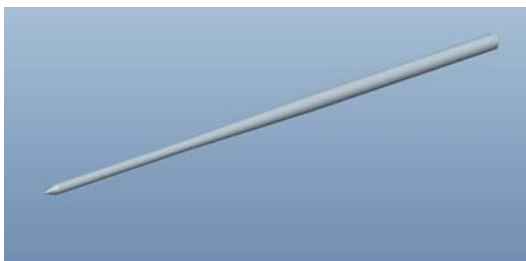

Figure 34: Spike exemplar T3.

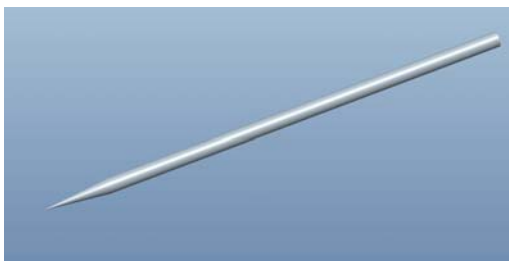

Figure 35: Spike exemplar T4.

7. Exemplar Evaluations

7.1 Quasi-Static

The exemplars described in Section 6 were evaluated to the same quasi-static tip sharpness, edge sharpness and push-through performance tests conducted for the survey weapon subset. The objective of the tests was to finalize the exemplar tip and edge sharpness based on the guidance provided by the tip/edge indentation results, and more importantly, the quasi-static push-through performance.

7.1.1 Methods

The test methodology has been previously described and the reader is referred to Section 5.

The four exemplar threat types (T1, T2, T3, T4) in Table 23 and Table 24 were to be tested in various configurations, each representing different degrees of tip and edge sharpness.

The same exemplars used for the tip sharpness and edge sharpness tests were used for the push-through tests due to the non-destructive nature of the tip and edge indentation tests. Further, single tests were conducted with the exemplars to establish trends in the results while limiting the number of exemplars used.

7.1.2 Results

The quasi-static test results are provided in Table 25 and Table 26 for the blades and spikes, respectively, and graphically depicted in Figure 36.

Table 25: Quasi-static performance of bladed exemplars.

Asset	Performance									
	Buckle Load Est. Free (N)	Flexural Stiffness Est. (N/mm)	Flexural Stiffness Act. @65 mm (N/mm)	Push-through Force Peak (N)	Push-through Plateau Slope L1 (N/mm)	Push-through Energy (J)	Perforation (mm)	Tip Sharpness (N)	Edge Sharpness (N)	Hardness (HRB)
Exemplar (T1)	1879	24	#N/A	#N/A	#N/A	#N/A	#N/A	#N/A	#N/A	55
T1C				243	#N/A	2.4		156	54	
T1C-1				164		1.7		138	180	
T1C-2				148		1.6		170	264	
T1C-3				201		2.3		206	265	
T1C-4				119		1.5		260	310	
T1C-5				257		1.9		325	355	
T1Db				149		2.2		230	301	
Exemplar (T2)	2324	27	#N/A	#N/A	#N/A	#N/A	#N/A	#N/A	#N/A	80
T2C				172		2.3		203	44	
T2C-1				203		2.3		217	297	
T2C-2				361		3.2		219	295	
T2C-3				455		4.2		240	310	
T2C-4				330		3.4		324	380	
T2C-5				396		4.2		279	354	
T2Db				224		2.8		225	227	

Table 26: Quasi-static performance of spiked exemplars.

Asset	Performance								
	Buckle Load Est. Free (N)	Flexural Stiffness Est. (N/mm)	Flexural Stiffness Act. @65 mm (N/mm)	Push-through Force Peak (N)	Push-through Plateau Slope L1 (N/mm)	Push-through Energy (J)	Perforation (mm)	Tip Sharpness (N)	Hardness (HRB)
Exemplar (T3)	191	2.7	#N/A	#N/A	#N/A	#N/A	#N/A	#N/A	68
T3D				54		0.1		271	
T3D-1				80		0.2		293	
T3D-2				223		1.2		314	
T3D-3				189		0.7		304	
T3D-4				228		1.2		301	
Exemplar (T4)	344	4.9	#N/A	#N/A	#N/A	#N/A	#N/A	#N/A	68
T4C				164.9		1.1		73	
T4C-1				151.9		1.3		140	
T4C-2				160.5		1.4		199	
T4C-3				393.0		3.3		255	
T4C-4				508.2		0.0		278	

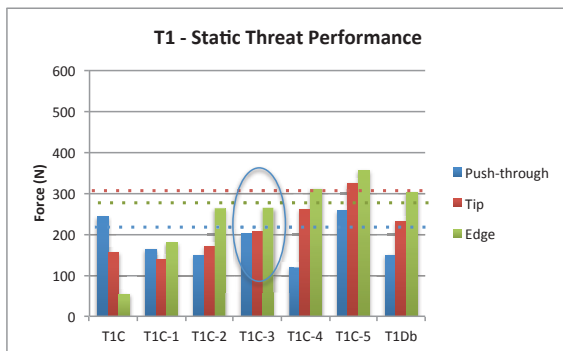

(a) T1 Exemplar

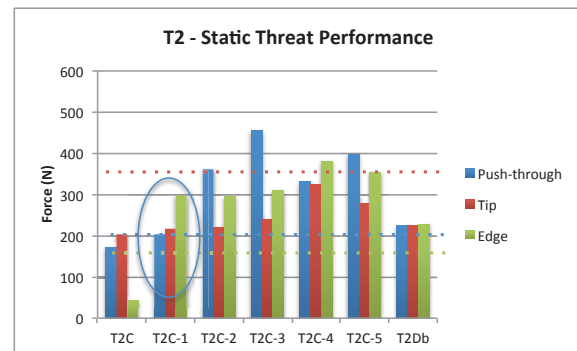

(b) T2 Exemplar

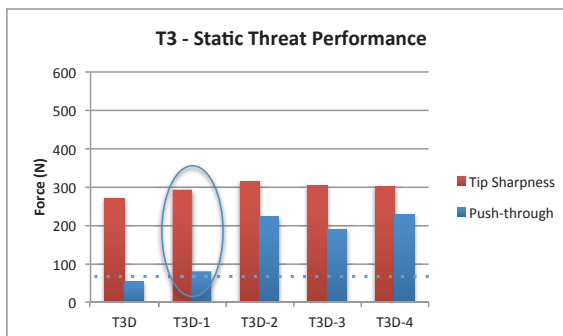

(c) T3 Exemplar

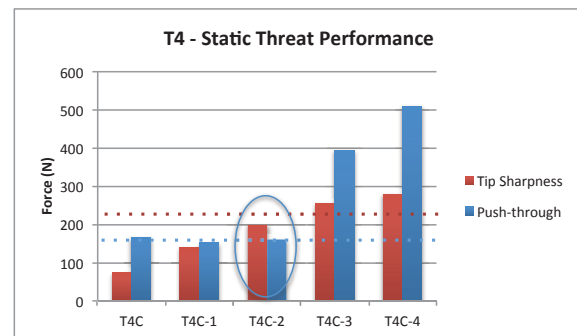

(d) T4 Exemplar

Figure 36: Quasi-static performance plots for the exemplars.

Comparison of the exemplar performance to the average survey weapon subset measurements can be made with the dashed lines in the figures. It may be observed that some variability of the exemplar threats exists with the tip, edge and push-through data for the different exemplars.

However, for the spikes, a general trend can be seen where peak force increases as the tip sharpness levels decreased. Greater variability exists for the blades and is thought to be due to the additional armour interactions involving separation and cutting of the fibres. Additional testing is required to establish confidence bounds on the exemplar responses however this was outside the scope of the proposed program.

Disparity between the exemplar tip/edge sharpness measurements and the averaged weapon data can be seen in Figure 36. The reasons for this are not fully understood but are thought to be attributed to differences in surface finish, edge geometry, and test variability. Again, additional testing is required to establish the confidence bounds on the exemplar responses.

Selection of the appropriate sharpness levels was based primarily on the push-through results as the tip and edge forces did not always align with the push-through trends. The selected exemplars are presented in Table 27.

Table 27: Final exemplar specifications.

Type	Description	Notation
Blade	Single edged, asymmetrical	T1C-3
Blade	Double edged, symmetrical	T2C-1
Spike	Small dia., short taper	T3D-1
Spike	Med. dia., long taper	T4C-2

7.2 Dynamic

Dynamic evaluation of the threat-armour interaction is required to replicate the armour interactions during a stab attack. The most prominent test methodologies include the NIJ 0115 Stab Resistance Standard and the HOSDB Body Standard for UK Police Officers (2007): Part 3 Knife and Spike Resistance, [NIJ 2000; Croft and Longhurst 2007]. Both methods evaluate the penetrating failure of body armour through the use of a guided free-fall drop mass. The threats are attached to a sprung mass system to replicate the dual peak force transmission profile representative of handheld weapons. A rubber and foam backing supports the armour samples and provides a degree of biofidelity allowing the armour to deflect and absorb some of the impact energy during the impact event. Penetration depths of 7 mm and 20 mm are specified as allowable limits for each of the three performance levels and over-proof levels, respectively.

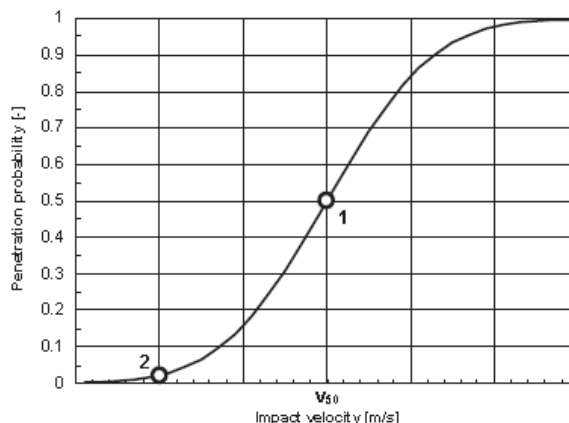

Figure 37. Armour penetration probability.

The test methodology specified in the NIJ 0115.00 standard was used as a basis for dynamic evaluation of the exemplar threats. The method, however, provides limited information on the degree of failure, or success, of armour performance for different stab-resistant armour systems and threats. An alternative approach, based on the V_{50} procedure described in various ballistics performance standards (e.g. MIL-662F, STANAG 2920, NIJ 0101.06), will be used to define the point of armour failure. Current standards define the V_{50} (e.g. point 1 in Figure 37) as the arithmetic mean of the velocity of an even number of shots, half of which perforate the material, half of which do not. The highest and the lowest velocities of the group of shots must be within a predefined velocity spread (e.g. 40 m/s). Similarly, an L_{50} procedure is proposed for the exemplar threats to establish the number of armour layers (L) required to defeat the threat. The point at which a 50% risk of failure exists, will be used as the objective function for determining the required number of layers, " L_{50} ". The L_{50} is defined as the arithmetic mean of the number of layers from which an even number, preferably six drops, are made and half of which perforate the target material, half of which do not. The highest and lowest number of layers associated with failure should be within a reasonable spread (i.e. 1-2 layers). In this procedure, the failure criterion is defined as penetration through the last layer of sample armour material that is greater than 7 mm in depth.

In comparison to the pass/fail procedure described in NIJ 0115.00, the L_{50} approach provides information on the performance of the a stab-resistant armour against the exemplars defined previously. With 10 drops targeted per armour/weapon configuration, the L_{50} obtained will be used to grade both armour performance and threat severity. Further, cross-reference to the existing performance levels of the NIJ and HOSDB stab resistance standards can be achieved.

7.2.1 Methods

The test methodology described by NIJ 0115.00 was used for the dynamic evaluation of exemplar threat performance. Differences to the test energy and armour sample selection were implemented to address recommendations of the chair of the Special Technical Committee during the September 2013 meeting in regards to the appropriate test energy. All exemplar tests were to be completed to the single energy level corresponding to the NIJ 0115.00 Level 3, E1 (43 J). The associated 7 mm penetration limit was used as the failure criterion for the current armour layer evaluation. In regards to armour selection, the number of layers were varied according to the requirements for the L_{50} determination.

A proposed test matrix is presented in Table 28. A total of 10 drop tests for each threat type is required to satisfy the L_{50} test methodology. New threats are used for each test and replacement of the backing materials, compression disks and witness paper follow the standard testing schedule of the NIJ 0115.00 standard.

Table 28: Test matrix for dynamic assessment of the exemplar threats.

Exemplar	Energy (J)	Armour Type	Layers*
T1C-3	43	Twaron Aramid SRM 509/930, loose layup	1-10
T2C-1	43	Twaron Aramid SRM 509/930, loose layup	1-10
T3D-1	43	Twaron Aramid Fabric - Microflex 60" (550 DTEX) Special HS, loose layup	1-10
T4C-2	43	Twaron Aramid Fabric - Microflex 60" (550 DTEX) Special HS, loose layup	1-10

* Note: The number of layers are determined during testing to achieve an equal number of pass/fail data points.

7.2.2 Results

The dynamic performance evaluation of the bladed and spiked threats are presented in Table 29 and Table 30, respectively. It may be noted that for the spike tests, not all 10 impacts were conducted due to damage to the threat holders from the threat striking the steel support plate located under the backing. Penetration measurements were taken with a graduated steel ruler as

determination from the witness paper was not possible due to tearing of the paper. The penetration modes were unremarkable while blade failure during non-penetration only existed for the spikes with T3 exhibiting multiple bending modes and T4 exhibiting bending along the tip taper for the majority of cases.

Table 29: Dynamic evaluation results of the bladed exemplars.

Strike	Threat	No. Layers	Angle of Incidence	Velocity - Actual (m/s)	Energy - Actual (J)	Penetration - Measured (mm)	No. Layers for L50
1	T1C-3	12	0	6.73	43.0	7	12
2	T1C-3	16	0	6.74	43.1	7.5	
3	T1C-3	18	0	6.74	43.2	2	
4	T1C-3	14	0	6.76	43.4	4	
5	T1C-3	13	0	6.74	43.1	8	13
6	T1C-3	11	0	6.76	43.4	11	11
7	T1C-3	10	0	6.73	43.1	12	10
8	T1C-3	9	0	6.71	42.8	20	
9	T1C-3	8	0	6.75	43.2	19	
10	T1C-3	15	0	6.73	43.1	3	
1	T2C-1	16	0	6.70	42.7	1	
2	T2C-1	14	0	6.73	43.0	1	14
3	T2C-1	10	0	6.72	42.9	11	10
4	T2C-1	9	0	6.74	43.2	12	9
5	T2C-1	8	0	6.73	43.0	17	
6	T2C-1	7	0	6.73	43.0	20	
7	T2C-1	12	0	6.73	43.0	4	12
8	T2C-1	11	0	6.75	43.2	8.5	11
9	T2C-1	13	0	6.71	42.8	4	13
10	T2C-1	15	0	6.73	43.1	1	

Table 30: Dynamic evaluation results of the spiked exemplars.

Strike	Threat	No. Layers	Angle of Incidence	Velocity - Actual (m/s)	Energy - Actual (J)	Penetration - Measured (mm)	No. Layers for L50
1	T3D-1	16	0	6.73	43.0	0	
2	T3D-1	11	0	6.71	42.8	0	
3	T3D-1	9	0	6.71	42.7	0	
4	T3D-1	7	0	6.72	42.9	0	
5	T3D-1	4	0	6.72	42.9	86	4
6	T3D-1	5	0	6.70	42.7	0	5
7	T3D-1	6	0	6.70	42.7	0	6
8	T3D-1	3	0	6.72	42.8	86	3
1	T4C-2	8	0	#N/A	#N/A	0	
2	T4C-2	8	0	6.71	42.7	5	8
3	T4C-2	7	0	6.69	42.5	6	7
4	T4C-2	6	0	6.71	42.8	70	6
5	T4C-2	5	0	6.69	42.5	70	5
6	T4C-2	9	0	6.72	42.9	0	

The L₅₀ assessment results are found in Table 31 along with rudimentary statistics. The arithmetic mean and standard deviations are based on the selected number of layers used for the L₅₀ assessments.

It may be noted that the required number of layers to meet the 7 mm failure criterion with a 50% risk level was the same for the two blades while the T3 blade was defeated with fewer layers of armour. Comparison of the two armour materials was outside the current scope of the program.

Table 31: L₅₀ assessment for all exemplars.

Threat	Armour	L50 Mean	Low	High	Std. Dev.
T1C-3	Twaron Aramid SRM 509/930, loose layup	12	10	13	1.3
T2C-1	Twaron Aramid SRM 509/930, loose layup	12	9	14	1.9
T3D-1	Twaron Aramid Fabric - Microflex 60" (550 DTEX) Special HS, loose layup	5	3	6	1.3
T4C-2	Twaron Aramid Fabric - Microflex 60" (550 DTEX) Special HS, loose layup	7	5	8	1.3

Depiction of the L₅₀ test results are presented for the various exemplar threats in Figure 38. The 7 mm criteria is illustrated with a dashed line. Trendlines are approximate and are provided for illustrative purposes only.

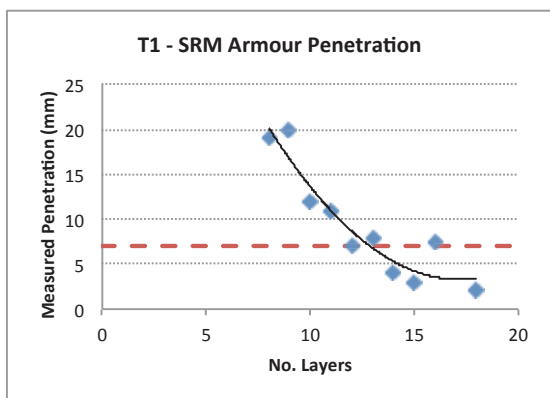

(a) T1 Exemplar

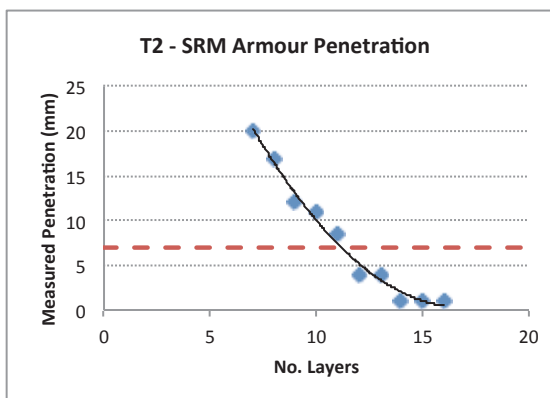

(b) T2 Exemplar

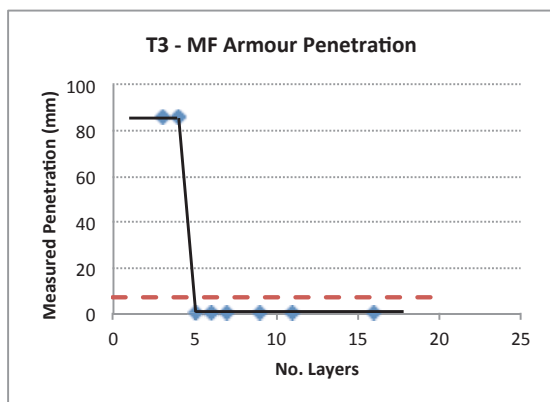

(c) T3 Exemplar

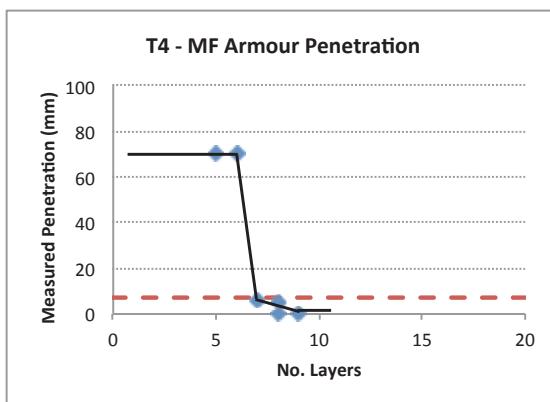

(d) T4 Exemplar

Figure 38: Dynamic test results of exemplar threats with various armour materials and layers.

8. Summary and Recommendations

In summary, four exemplar weapons were developed to represent the treats found in correctional facilities and may be considered for future updates of relevant body armour performance standards such as NIJ 0115.00. The following findings and recommendations can be noted:

- a stab weapon typology and taxonomy were successfully developed to identify potentially aggressive threats based on descriptive information,
- quasi-static performance tests were developed to characterize tip, edge and system performance for initial down-selection of stab weapons, however, additional work is required to establish confidence levels and potential for quality control measures of the exemplars,
- two bladed and two spiked exemplar weapons were developed from the geometric and performance characteristics of weapons obtained from correctional facilities in the US,
- the proposed exemplars require a lesser number of armour layers to meet the current penetration limits of NIJ 0115.00 in comparison to the P1/A and S1/G exemplars.
- Greater use of the exemplars from the practitioners is required to fully understand their implications on armour design, relevancy and test variability.

9. Acknowledgements

This work has been supported by Wayne State University, Contract No. 2011-DE-BX-K003. The technical expertise and oversight provided by Cynthia Bir, PhD and Nicholas Rowley are greatly appreciated.

10. References

- Atkins, T. (2009). **The Science and Engineering of Cutting: The Mechanics and Processes of Separating, Scratching and Puncturing Biomaterials, Metals and Non-metals.** Great Britain, Butterworth-Heinemann.
- Bleetman, A., C. H. Watson, et al. (2004). **Wounding Patterns of Human Performance in Knife Attacks: Optimising the Protection Provided by Knife-Resistant Body Armour.** *Personal Armour Systems Symposium.* The Hague, Netherlands, PASS.
- Carr, D. J., S. E. Kemp, et al. (2010). **Reproducing 'Real' Stabbing Events in the Laboratory: The Importance of a Textile Science Perspective.** *Personal Armour Systems Symposium.* Quebec City, Quebec, Canada, PASS: 53-59.
- Chadwick, E. K. J., A. C. Nicol, et al. (1999). **"Biomechanics of Knife Stab Attacks."** *Forensic Science International* **105**: 35-44.
- Croft, J. and D. Longhurst (2007). **HOSDB Body Armour Standards for UK Police (2007) Part 3: Knife and Spike Resistance.** 39/07/C. St Albans, Home Office Scientific Development Branch.
- Fenne, P. (2010). **Knives, Sharpness, Cutting and Body Armour Evaluation.** *Personal Armour Systems Symposium.* Quebec City, Quebec, Canada, PASS: 70-78.
- Gilchrist, M. D. and S. Keenan (2008). **"Measuring Knife Stab Penetration into Skin Simulant using a Novel Biaxial Tension Device."** *Forensic Sci Int* **177**(1): 52-65.
- Horsfall, I. (2000). **Stab Resistant Body Armour.** Shrivenham, Swindon, Cranfield University.
- Malbon, C. and J. Croft (2006). **HOSDB Slash Resistance Standard for UK Police (2006).** 48/05. St Albans, Home Office Scientific Development Branch.
- Marsot, J. and L. Claudon (2007). **"Assessment of Knife Sharpness by Means of a Cutting Force Measuring System."** *Appl Ergon* **38**(1): 83-89.
- McGorry, R. W. and P. C. Dowd (2005). **"The Effect of Blade Finish and Blade Edge Angle on Forces Used in Meat Cutting Operations."** *Appl Ergon* **36**(1): 71-79.
- McGorry, R. W. and P. C. Dowd (2005b). **"A Technique for Field Measurement of Knife Sharpness."** *Appl Ergon* **36**(5): 635-640.
- Miller, L. (1998). **Selection and Application Guide to Police Body Armor.** National Institute of Justice. Report No. NIJ Guide 100-98.

NIJ (2000). **Stab Resistance of Personal Body Armor**. NIJ 0115.00. Washington DC, US Department of Justice.

Saaty, T. L. and L. G. Vargas (2006). **Decision Making with the Analytic Network Process**. USA, Springer Science+Business Media, LLC.

SECRU (1999). **Investigation of Knife Stab Characteristics – I. Biomechanics of Knife Stab Attacks II. Development of Body Tissue Simulant**. Scottish Executive Central Research Unit. Report No.

Watson, C. H., I. Horsfall, et al. (2002). **Blade Sharpness and its Effects on the Testing of Body Armours**. *Personal Armour Systems Symposium 2002*, The Hague, The Netherlands.

Watson, C. H., I. Horsfall, et al. (2000). **Human Performance in Slash Attack**. *Personal Armour Systems Symposium*. DCTA Colchester, UK, PASS: 33-42.

(this page intentionally left blank)

Appendix A: Weapon Data Entry Table

Sample contents of worksheet:

"Data Entry Spreadsheet for Weapon Characterization BioK V40.xlsx".

Phase	Asset Type				Tip				
	Agency Type	Overall Length (mm)	Overall Weight (g)	Style	Description		Geometry and Material		
					Tip Material	Tip Shape Description	Tip Radius (mm)	Tip Cone (deg)	Spike Diameter (mm)
I - Typology	X	X	X	X	X	X		X	X
II - Effectiveness	X	X	X	X	X	X	X	X	X
III - Exemplar Development	X	X	X	X	X	X	X	X	X
Typical minima - maxima, criteria or descriptors used for error checking via Excel Conditional Formatting		10 450	1.0 500.0	blade ice pick slash stake	metal plastic wood glass	pointed curved square chiseled		2.0 180.0	1.00 20.00
						round			



Edge			Blade/Body							Handle		
Description		Geomet	Description							Description		
Edge Condition	No. Edges	Edge Grind Sides, Edge No. 1	Blade Material	Blade Shape - planar	Blade Spine	Blade Serrations (describe)	Blade Width (mm)	Spike Diameter (mm)	Blade Thickness (mm)	Handle Length (mm)	Handle Tang	Handle Guard
X	X		X	X	X	X	X	X	X	X	X	X
	X	X	X	X	X	X	X	X	X	X	X	X
X	X	X	X	X	X	X	X	X	X	X		
sharp	0	0	metal	sym	no	none	0.5	"=Col T	0.5	40	none	none
blunt	1	1	plastic	sqr	yes	top	66.0		15.0	500	partial	yes
serrated blunt	2	2	wood	rnd		bottom					full	
serrated sharp			glass	trg		both						
				serrated								



Performance Evaluation													
Description													
Armour System Description	No of Aramid Layers Weapon Perforated	Perforation (mm)	Stroke at Peak (mm)	Stroke L1 Start (mm)	Stroke L1 End (mm)	Force L1 Start (N)	Force L1 End (N)	Plateau Force L1 - slope (N/mm)	Stroke L2 Start (mm)	Stroke L2 End (mm)	Force L2 Start (N)	Force L2 End (N)	Plateau Force L2 - slope (N/mm)
X	X	X	X	X	X	X	X	X	X	X	X	X	X
X	X	X	X	X	X	X	X	X	X	X	X	X	X
make model etc													



Stroke L3 Start (mm)	Stroke L3 End (mm)	Force L3 Start (N)	Force L3 End (N)	Plateau Force L3 - slope (N/mm)	Peak Force (N)	Energy (J)	Failure Mode; Armour	Un-fair Test
X	X	X	X	X	X	X	X	X
X	X	X	X	X	X	X	X	X
							retention cutting fibre separation	threat premature failure threat slippage armour slippage sensor failure etc



Asset Characteristics				
Quasi-static Test Sample (Y/N)	Tip Test Max Force (N)	Edge Sharpness (N)	Hardness	Flexural Stiffness (N/mm)
X	X	X	X	X
X	X	X	X	X

Appendix B: Stab Weapon Measurement Guide

Stab Weapon Measurement Guide

Prepared for: Wayne State University

Prepared by: Biokinetics and Associates Ltd.

Date: 25 April, 2013

Supporting Documents:

Quasistatic Test Procedure V04.docx

Data Entry Spreadsheet for Weapon Characterization BioK V40.xlsx

1 Table of Contents

2	Weapon Styles:.....	B-4
2.1	Bladed.....	B-4
2.2	Ice Pick Style.....	B-4
2.3	Stake.....	B-5
2.4	Slash Style Weapon.....	B-5
3	Measurements.....	B-6
3.1	Overall Weapon Length:.....	B-6
3.2	Overall weight:.....	B-6
3.3	Tip.....	B-6
3.3.1	Tip Material.....	B-6
3.3.2	Tip Shape Description.....	B-7
3.3.3	Tip Radius (mm).....	B-7
3.3.4	Tip Cone Angle (deg).....	B-7
3.3.5	Tip Width (mm).....	B-8
3.3.6	Tip Length (mm).....	B-8
3.3.7	Tip Surface Finish.....	B-8
3.3.8	Tip Hardness.....	B-8
3.4	Edge.....	B-8
3.4.1	Edge Condition.....	B-8
3.4.2	Edge Radius, Edge No. 1 (mm).....	B-9
3.4.3	Edge Cone, Edge No. 1 (deg).....	B-9
3.4.4	Edge Radius, Edge No. 2 (mm).....	B-9
3.4.5	Edge Cone, No. 2 (mm).....	B-9
3.4.6	Edge Grind Sides, Edge No. 1.....	B-9
3.4.7	Edge Grind Sides, Edge No. 2.....	B-10
3.4.8	Edge 1 Tip - Start (mm).....	B-10
3.4.9	Edge 1 Length (mm).....	B-10
3.4.10	Edge 2 Tip - Start (mm).....	B-10
3.4.11	Edge 2 Length (mm).....	B-10
3.4.12	Edge Hardness (Vickers).....	B-10
3.5	Blade.....	B-10
3.5.1	Blade Material.....	B-10
3.5.2	Blade Shape - planar.....	B-11
3.5.3	Blade Spine.....	B-11
3.5.4	Blade Serrations (describe).....	B-11
3.5.5	Blade Width (mm).....	B-11
3.5.6	Spike Diameter (mm).....	B-12
3.5.7	Blade Thickness (mm).....	B-12
3.5.8	Blade Surface Finish.....	B-12
3.5.9	Blade Hardness.....	B-12
3.6	Handle.....	B-12
3.6.1	Handle Length (mm).....	B-12
3.6.2	Handle Tang.....	B-12
3.6.3	Handle Guard.....	B-12
4	Performance Variables.....	B-13
4.1	Armour System Description.....	B-13
4.2	Perforation (mm).....	B-13
4.3	Stroke.....	B-13
4.4	Stroke Start (mm).....	B-13
4.5	Stroke End (mm).....	B-13
4.6	Peak Force.....	B-13
4.7	Plateau Force Start (N).....	B-14

4.8	Plateau Force End (N)	B-14
4.9	Plateau Force Slope (\pm N/mm)	B-14
4.10	Energy (J)	B-14
4.11	Failure Mode; Armour	B-14
4.12	Failure Mode; Threat.....	B-14
4.13	Video.....	B-14
4.14	Fair/Un-fair Test.....	B-14

2 Weapon Styles:

2.1 Bladed

Bladed weapons are categorized as the main body of the weapon consisting of flat metal exhibiting one or more sharpened edges and tip. A handle may or may not exist. The main function of the blade is to penetrate the body or armour with the tip and to provide some cutting action with a sharpened edge. Blunt tipped or blunt edged weapons are still considered bladed weapons. The main mode of use is with a thrust action.



Figure 39 Bladed Style (pictures courtesy of Wayne State University).

2.2 Ice Pick Style

An ice pick weapon is categorized by the body being of slender nature and typically of circular cross section. The ice pick may be pointed or blunt and with to without a handle. The weapon can also be viewed as a spike with an objective to penetrate the body or armour system without cutting. The main mode of use is with a thrust action.



Figure 40 Ice Pick Style

2.3 Stake

A stake is categorized as a bladed weapon if irregular cross section or improvised from irregular objects. Stakes make include blunt or sharp tipped and edged features and may or may not have a handle. The main function of the stake is to penetrate the body or armour with the tip and to provide some cutting action with a sharpened edge if available. The main mode of use is with a thrust action.



Figure 41 Stake Style

2.4 Slash Style Weapon

Slash weapons are primarily to be used with a swiping action and exhibit a sharp cutting edge to slash the body or armour system. A sharpened tip is usually absent and a handle exists to support the cutting blade.



Figure 42 Slash Style

3 Measurements

3.1 Overall Weapon Length:

The overall length of the weapon includes the measurement from tip to butt including the handle, if any.



Figure 43 Overall Weapon Length

3.2 Overall Weight:

The weapons are to be weighed in grams with an accuracy of two decimal places.

3.3 Tip

3.3.1 Tip Material

The different types of materials were divided into four general categories

- Metal
- Plastic
- Wood
- Glass

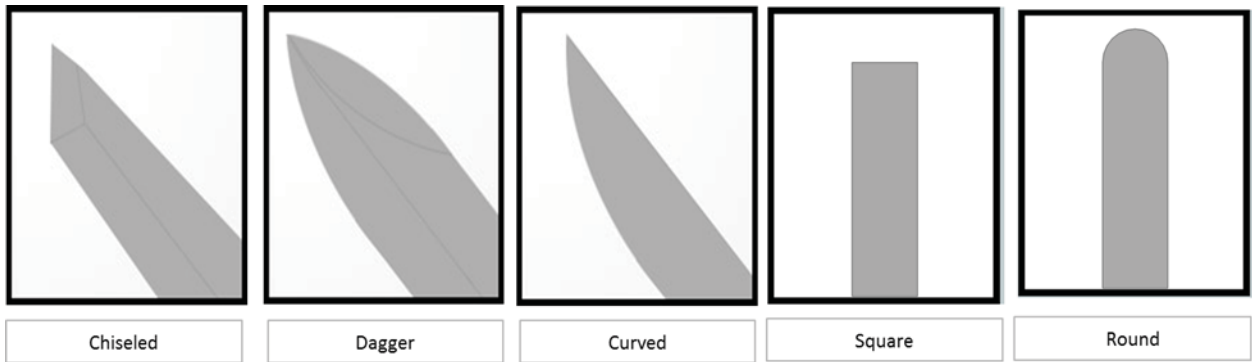

Figure 6 Tip Shape for Bladed Styles

3.3.2 Tip Shape Description

Description of the planar shape, i.e. Pointed, Curved, Square, Chiselled.

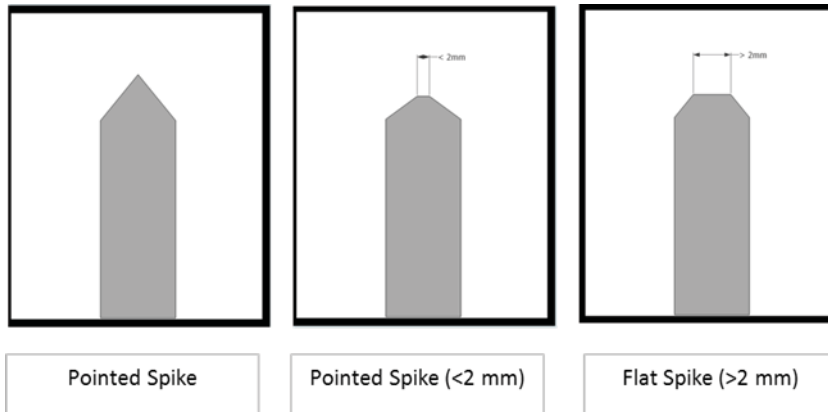

Figure 7 Ice Pick Style Tip and Edge Conditions

3.3.3 Tip Radius (mm)

Radius of the tip of the cone or point (mm). The radius is to be limited to the area responsible for initial penetration.

3.3.4 Tip Cone Angle (deg)

Included angle of the tip.

- Measure the cone angle within the first 2 mm.
- The cone angle median axis is relative to the handle.
- Cone angle 180 degrees for flat and blunt round tips.

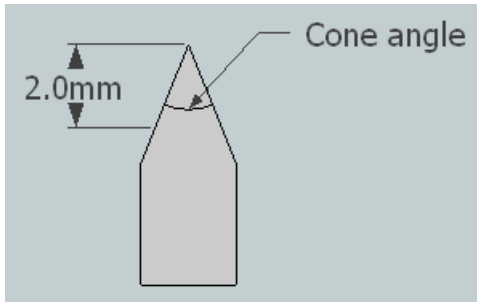

Figure 9 Cone Angle - Pointed

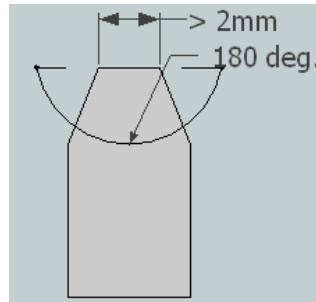

Figure 8 Cone Angle - Flat or Rounded

3.3.5 Tip Width (mm)

Needed for calculation of cone angle unless measured directly. The width is to be measured at the completion of the tip length, see below.

3.3.6 Tip Length (mm)



Figure 10 Tip Length

The taper length at the tip of the weapon is the measured distance of the side or sides which have been grinded down to make a point. (NB –the taper length was only measured for ‘ice Pick’ style weapons). The tip length is to be used for the cone angle calculation, unless measured directly.

3.3.7 Tip Surface Finish

Tip surface texture characteristic, primarily roughness, expressed as RMS roughness, i.e. 64 ($\mu\text{in RMS}$).

3.3.8 Tip Hardness

The tip hardness defines the hardness of the material near the tip. Due to high weapon curvatures and irregular shapes, it is suggested to use the Vickers hardness method with a micro-indenter. The measurement surface may require grinding to a flat surface depending on the guidelines for the measurement technique.

3.4 Edge

3.4.1 Edge Condition

The *blunt* edge condition is predicated on the sharpened edge being greater than 2 mm. Anything thinner can be considered to be *sharp*.

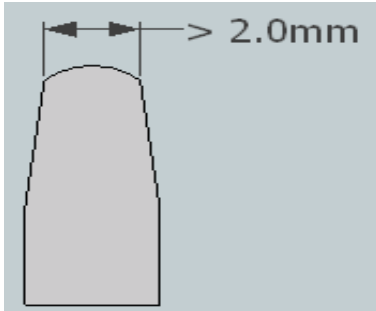

Figure 11 Edge Condition – Blunt and Sharp

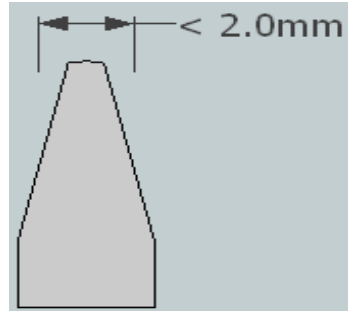

Figure 12 Edge Condition – Blunt

No. Edges

The total number of edges which of the weapon which interact with the body or armour system, regardless of condition.

3.4.2 Edge Radius, Edge No. 1 (mm)

The radius of a sharp side formed by the intersection of two side surfaces of an object.

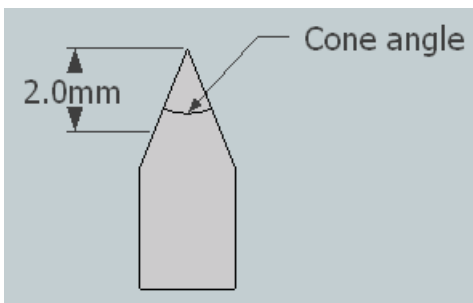

Figure 13 Edge Cone

3.4.3 Edge Cone, Edge No. 1 (deg)

Included angle of cutting edge.

3.4.4 Edge Radius, Edge No. 2 (mm)

Edge Radius (mm) for the second edge if there is more than one cutting edge.

3.4.5 Edge Cone, No. 2 (mm)

Included angle of cutting edge for the second edge if there is more than one cutting edge.

3.4.6 Edge Grind Sides, Edge No. 1

The number of grind sides for the edge.



Figure 15 One Sided Grind



Figure 14 Two Sided Grind

3.4.7 Edge Grind Sides, Edge No. 2

The number of grind sides for the second edge if there is more than one cutting edge.

3.4.8 Edge 1 Tip - Start (mm)

The arc length from the tip to the start of the cutting edge in plan view.

3.4.9 Edge 1 Length (mm)

Arc length of cutting edge.

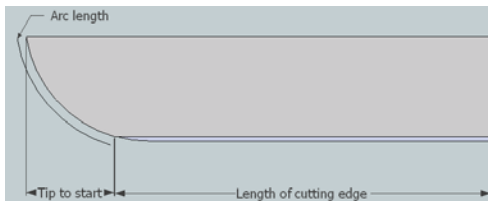

Figure 16 Tip to Start & Edge Length

3.4.10 Edge 2 Tip - Start (mm)

The taper distance from the tip to the start of the cutting edge in plan view for the second edge if there is more than one cutting edge.

3.4.11 Edge 2 Length (mm)

Arc length of cutting edge for the second edge if there is more than one cutting edge.

3.4.12 Edge Hardness

The edge hardness defines the hardness of the material near the edge. Due to high weapon curvatures and irregular shapes, it is suggested to use the Vickers hardness method with a micro-indenter. The measurement surface may require grinding to a flat surface depending on the guidelines for the measurement technique.

3.5 Blade

3.5.1 Blade Material

The different types of materials were divided into four general categories

- Metal
- Plastic
- Wood

- Glass

3.5.2 Blade Shape - planar

1. A symmetrical blade is the shape of an isosceles triangle – a tip with two equal sides and angles.
2. A round blade is a blade with a rounded edge
3. A square blade is a blade with two distinct corners at the end.
4. A blade shape is described as a triangle if it has a tip and two unequal sides.
5. A serrated blade is a blade with jagged edges.



Figure 44 Symmetrical



Figure 45 Rounded



Figure 46 Square



Figure 47 Triangular



Figure 48 Serrated

3.5.3 Blade Spine

A thick unsharpened edge that adds support to the weapon. Yes or No.

3.5.4 Blade Serrations (describe)

Blade body serrations not part of edge (None, top, bottom, both).

3.5.5 Blade Width (mm)

Maximum width. Enter zero for spike.

3.5.6 Spike Diameter (mm)

For ice pick style weapons, an average of five measurements of the diameter was calculated to determine the average spike diameter.



Figure 22 Spike Diameter

3.5.7 Blade Thickness (mm)

For bladed weapons, an average of five measurements of the blade thickness was calculated to determine the average blade thickness.

3.5.8 Blade Surface Finish

Blade surface texture characteristic, primarily roughness, expressed as RMS, i.e. 64 ($\mu\text{in RMS}$).

3.5.9 Blade Hardness

The blade hardness defines the hardness of the material on the blade body. Due to high weapon curvatures and irregular shapes, it is suggested to use the Vickers hardness method with a micro-indenter. The measurement surface may require grinding to a flat surface depending on the guidelines for the measurement technique.

3.6 Handle

The handle is the appendage to a weapon that is designed to be held in order to use the weapon. The handle may be a constituent element of the system necessary for the functioning of the weapon or simply a modification of the structure to enhance grip.

3.6.1 Handle Length (mm)

The overall length of the handle.

3.6.2 Handle Tang

Full (runs length of handle), Partial, None

A tang or shank is the back portion of a tool where it extends into stock material or is connected to a handle as on a knife. A Full tang extends the full length of the grip-portion of a handle, versus a partial tang which does not. The purpose of documenting this is to give a clue to the robustness of the weapon and its ability to deliver force

3.6.3 Handle Guard

Enter presence of a handle guard: Yes, No.

The purpose is to guard the hand from slipping down the handle and over the blade. The guard enables more force to be applied.

4 Performance Variables

This section pertains to the quasi-static test series comprising stab armour and improvised weapon. The test variables and response metrics are to be documented. The test methodology, test materials, measurement methods and constant variables are documented separately (see: Quasi-static Test Procedure.docx).

4.1 Armour System Description

Describe the test sample including the sample pack no., model and number of layers of woven material. Cross reference test constants including the test material make, batch no., denier, coatings and areal density.

4.2 Perforation (mm)

The perforation is intended to be measured as the distance of the tip to the backface of the armour consistently between all tests. As stroke length in itself does not relate to stab performance, it is desired to measure the perforation when either the peak exerted force or energy delivery is reached or when the maximum stroke of the Instron has been reached. Perforation is measured after one of the limits has been reached by carefully removing the witness paper from the weapon and placing the paper over the tip of the weapon and measuring the amount of penetration into the created hole or slit in the paper. Care should be taken to not expand the hole during this process. Measure the penetration with vernier callipers.

Time histories of the weapon perforation can be documented separately if a real-time measurement system is used in place of the witness paper.

4.3 Stroke

Stroke is the total displacement of the Instron head from initial contact to test completion. Time histories of the Instron head stroke are required from initial setup to completion of the test. If the test is aborted, enter =NA().

4.4 Stroke Start (mm)

The stroke start and stroke end are meant to coincide with the plateau force start and end measurements for the purpose of calculating the plateau force slope. Enter this information into the database.

4.5 Stroke End (mm)

The stroke start and stroke end are meant to coincide with the plateau force start and end measurements for the purpose of calculating the plateau force slope. Enter this information into the database.

4.6 Peak Force (N)

The peak Instron head force achieved during the test is to be calculated from the measured time-histories, which is to be recorded.

The peak is intended to coincide with the tip perforation or the maximum load achieved at the time of test abortion, i.e. when the test stroke/force/energy limits have been reached.

4.7 Plateau Force Start (N)

If applicable, the plateau force start is to be determined from the Instron head force-time histories. This reflects the force immediately after perforation was achieved and where some force relaxation is observed. Enter =NA() if perforation was not achieved.

4.8 Plateau Force End (N)

The maximum force at test completion, different from Peak Force. Enter =NA() if perforation was not achieved.

4.9 Plateau Force Slope (\pm N/mm)

Instron head force slope after initial penetration. This is calculated in the weapon database. This is approximate slope of the resisting force as the weapon is further penetrated into the test sample.

4.10 Energy (J)

This is the energy applied by the Instron head. The energy time-history is to be documented and calculated in real-time for limiting the stroke of the Instron head. Document the maximum energy at test completion in the weapon database.

4.11 Failure Mode; Armour

Document the mode of failure at completion of the test including qualitative mentioning of cutting or separation of fibres and retention failure of the test sample where applicable. Enter this into the weapon database.

4.12 Failure Mode; Threat

Document the mode of weapon failure including qualitative mentioning of tip bending, blade body bending, fracture of the tip, fracture of the body, lost integrity, and retention failure of the weapon. Enter this into the weapon database.

4.13 Video

Document the video file ID number to link video to specific test in the weapon database.

4.14 Fair/Un-fair Test

Document the fairness of the test including:

- Unfair: threat premature failure, armour slippage, threat slippage, sensor failure, etc.
- Fair: test completed without incident and within operating parameters.

Appendix C: Push-through Testing Guidelines

Push-through Weapon Testing with Stab Armour - DRAFT Test Method -

1 Introduction

A test method is provided to guide the quasi-static testing of stab weapons with armour packs. The method controls the force and displacement applied to improvised stab weapons and provides guidelines for setup, initialization, measurements and data collection and analysis requirements.

2 Materials and Equipment

The test setup is shown in Figure 49. It consists of



Figure 49: Instron test setup.....

Details of the model, specifications and configurations are provided for the listed test equipment. Their setup and usage are defined in the Section (3), Methods.

Instron.....

Sample clamp and tensioning equipment.....

Weapon clamp.....

Control software.....

Data acquisition.....

Sample backing material and witness paper should comply with NIJ 0115.00 composite backing material, see Figure 50. The backing does not need to be certified. Replacement of the upper layers are required for damage that may occur during testing. The backing size must fit within the clamping frame. All layers of the backing and paper are to be freely laid upon each other.

Witness paper to be used for perforation measurement must comply with or be similar to the specification outlined in NIJ 0115.00. The size is to be similar to the backing material. The witness paper is to be freely laid upon the backing material.

Vernier calipers are required for measuring perforation. An accuracy of ± 0.5 mm is required.

3 Methods

The following procedures define the actions required to accomplish specific tasks. These include general guidelines for placement and adjustment of the equipment, fixtures, weapons and test samples.

3.1 Instron Preparation

Settings for maximum stroke, peak force, energy.....

3.2 Armour Clamping

The objective of the armour clamp is to both secure the test sample from being pulled in during stroking of the weapon, and; to provide an initial tension prior to loading.

(WSU) The clamp consists of

The fabric tension is to be measured with a tensiometer and without the backing support in place (see Figure 50). The target tension is $xx.x \pm xx$ N measured at the centre of the sample only.

3.3 Armour Backing Support and Witness Paper

One method for measuring armour perforation is proposed to use the NIJ 0115.00 type methodology consisting of a backing material and witness paper. The backing provides a means to keep the witness paper in contact with the backface of the armour sample while the weapon penetrates the witness paper. If required, the backing intermediate layer (polyethylene foam) can be increased to allow for greater stroke of the Instron machine head.

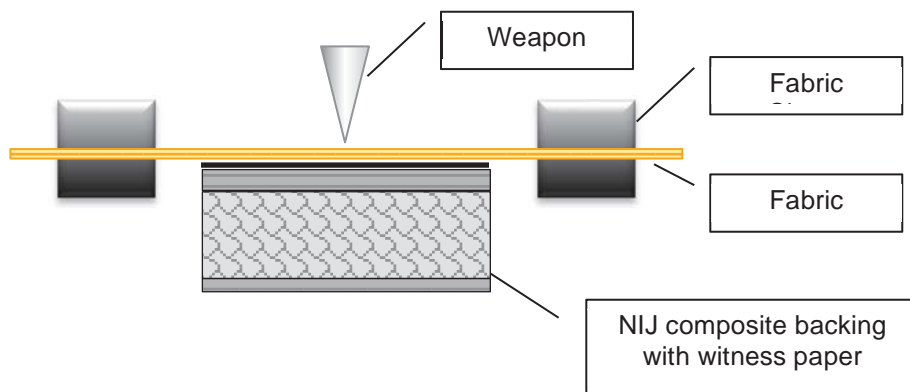

Figure 50: Armour sample backing support and witness paper setup, sectional view.

3.4 Weapon clamping

The weapon clamping head consists of

The weapon is intended to be clamped at the same point where the hand would be placed with full support at mid-length of the handle to reflect its mode of use and properly constrain the weapon for those that may involve buckling.

The distance from the tip to mid-handle can be calculated from the weapon database entries by subtracting half the handle length from the overall weapon length. If there is no handle, full clamping support shall be provide 40 mm from the back of the weapon, representing approximately half the palm width of a hand.

The weapon is to be placed in the Instron head clamp with the longitudinal axis of the weapon aligned with line of action of the Instron head and perpendicular with the test sample. The contact point of the test sample with the tip of the weapon should be in the centre or the test sample to avoid offset loads.

3.5 Operating Parameters

The proposed test limits for the quasi-static tests are presented below. These are from the literature [Chadwick 1999] for the 95th percentile values and likely represents the upper limit of the threat since some and energy and force dissipation will occur in real life attacks.

Peak Force 1885 N

Peak Energy 62 J

The intent is to work the threat within its first 7 mm; this is the region of interest. Therefore, limited perforation of the armour is desired for all threats. Given that the perforation through the armour is not monitored in real-time, stopping points are defined. As stroke length in itself does not relate to stab performance, it is desired to measure the perforation when either the peak exerted force or energy delivery is reached or when the maximum stroke of the Instron has been reached.

3.6 Measurements

3.6.1 Sign Conventions and Units

The following positive sign conventions are to be used:

- Compressive force applied by the Instron machine
- Perforation of the weapon through the armour sample
- Instron machine head stroke towards the test sample

Units are to follow SI conventions with the following:

- Forces = Newton (N)
- Displacements = millimeter (mm)
- Length = millimeter (mm)
- Energy = Joule (J) (Newton-metre, Nm)

3.6.2 Perforation (mm)

The perforation is intended to be measured as the distance of the tip to the backface of the armour consistently between all tests. As stroke length in itself does not relate to stab performance, it is desired to measure the perforation when either the peak exerted force or energy delivery is reached or when the maximum stroke of the Instron has been reached.

Perforation is measured after one of the limits has been reached by carefully removing the witness paper from the weapon and placing the paper over the tip of the weapon and measuring the amount of penetration into the created hole or slit in the paper. Care should be taken to not expand the hole during this process. Measure the penetration with vernier callipers. Enter this information into the database.

Time histories of the weapon perforation can be documented separately if a real-time measurement system is used in place of the witness paper.

3.6.3 Stroke at Peak (mm)

Time histories of the Instron head stroke are required from initial setup to completion of the test, Figure 51. Enter this information into the database.

The stroke at the peak force during the complete test. Alternatively, the maximum stroke at the completion of the testing is to be noted if the peak force coincides with test completion.

3.6.4 Stroke L1/2/3 Start (mm)

The stroke start is meant to coincide with the plateau force peak for perforation of layer 1, 2 or 3. The measurements are used for calculating the plateau force slope. Enter this information into the database for each layer of fabric.

3.6.5 Stroke L1/2/3 End (mm)

The stroke end is meant to coincide with the force finish endpoints after perforation of layer 1, 2 or 3. The measurements are used for calculating the plateau force slope. Enter this information into the database for each layer of fabric.

3.6.6 Force L1/L2/L3 Start (N)

The force at the start of perforation into the fabric is to be determined from the Instron head force-time histories.

This reflects the force immediately after perforation was achieved, Figure 51. Enter this information into the database for each layer of fabric.

3.6.7 Force L1/L2/L3 End (N)

The force at the end of perforation into each layer is to be determined from the Instron head force-time histories.

This reflects the force immediately after perforation where some force relaxation is observed, Figure 51. Enter this information into the database for each layer perforated.

3.6.8 Force Slope L1/L2/L3 (N/mm)

This is approximate slope of the resisting force as the weapon is further penetrated into the test sample. An average can be calculated from the force and displacement values at the force start and end for each layer, Figure 51. The value is calculated within the database. Correct choice of the start and end points is required from the force and stroke data.

$$\text{Slope} = (Force_{end} - Force_{start}) / (Stroke_{end} - Stroke_{start}) \quad \text{Eqn 1.}$$

3.6.9 Peak Force (N)

The peak Instron head force achieved during the complete test is to be calculated from the measured time-histories, which is to be recorded.

The peak is intended to coincide with the tip perforation or the maximum load achieved at the time of test abortion, i.e. when the test stroke/force/energy limits have been reached, Figure 51. Enter this information into the database.

3.6.10 Energy (J)

This is the energy applied by the Instron head. It is to be calculated from the following:

$$Energy = \int_{S=0}^S F dS \quad \text{Eqn 2.}$$

Where: F is the instantaneous force (N)

S is the instantaneous stroke (m)

The energy time-history is to be documented and calculated in real-time for limiting the stroke of the Instron head.

Document the maximum energy at test completion in the weapon database.

3.6.11 Failure Mode; Armour

Document the mode of failure at completion of the test including qualitative mentioning of cutting or separation of fibres and retention failure of the test sample where applicable. Enter this into the weapon database.

3.6.12 Fair/un-fair Test

Document the fairness of the test including:

- Unfair: threat premature failure, armour slippage, threat slippage, sensor failure, etc.
- Fair: test completed without incident and within operating parameters.

3.6.13 Failure Mode; Threat

Document the mode of weapon failure including qualitative mentioning of tip bending, blade body bending, fracture of the tip, fracture of the body, lost integrity, and retention failure of the weapon. Enter this into the weapon database.

3.6.14 Video

Document the video file ID number to link video to specific test in the weapon database.

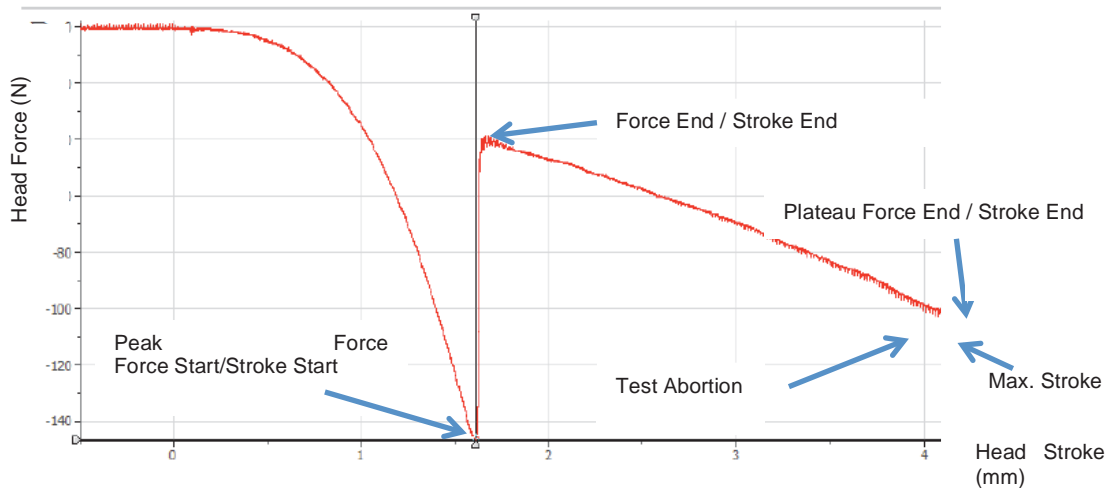

Figure 51: Typical force-displacement plot of an Instron head during a quasi-static test.

3.7 Initial Setup and Measurement Initialization

3.7.1 Test Sample Placement

The fabric armour tests packs are to be placed in the clamp fixture with the warp and weft aligned with the sides of the clamp frame.

Smooth out any wrinkles and capture the sample with the upper clamping frame.

Apply a clamping force sufficient to bring the tension to the target value (Section 3.2).

Mark the centre of the test sample with a marker. This point should intersect the line of action of the Instron head.

3.7.2 Weapon Clamping and Placement

Place the weapon into the Instron head clamp and align the longitudinal axis of the weapon to be perpendicular to the test sample. The contact point of the test sample with the tip of the weapon should be in the centre of the test sample to avoid offset loads.

Lower the weapon onto the test sample so that it is just in contact with the surface at the centre mark.

3.7.3 Pre-test Setup

Install the backing support and witness paper to be in touch with the backface of the armour sample. The witness paper and top layer of the backing should be without prior damage.

Zero the Instron displacement and force measurements.

Zero the software routines calculations peak force and energy calculations that will govern the Instron motion limits.

Ready all data acquisition and video collection systems where applicable.

3.8 Test Execution

Commence data collection and start head movement of the Instron machine.

Run the test to completion within the operating parameters.

Stop data collection.

Retract the Instron head and remove the witness paper.

4 Data Collection and Processing

Collect and process all measures stated in Section 3.6, Measurements.

5 Documentation

Enter the setup and measurement information described in the weapon database worksheet. Files of the time-histories and processed data are to be kept in separate data folders in Excel® worksheet format containing the time histories for all measurements and calculated values.

Appendix D: Exemplar Threats Engineering Drawings

Exemplar T1

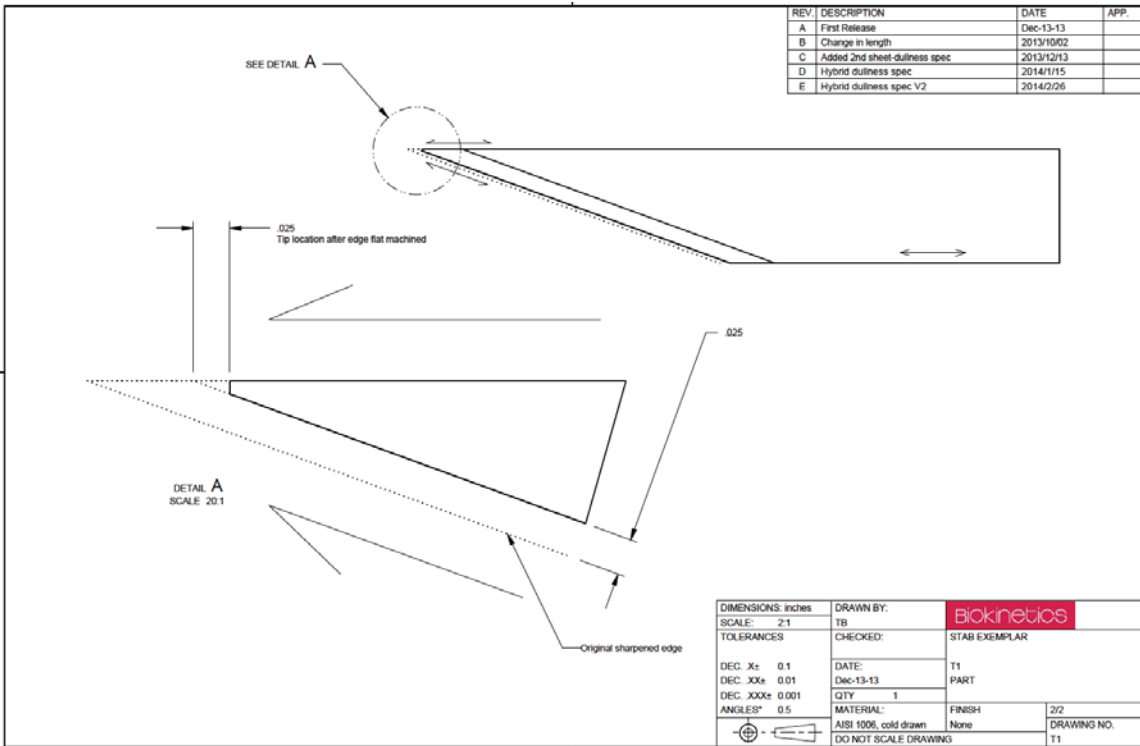
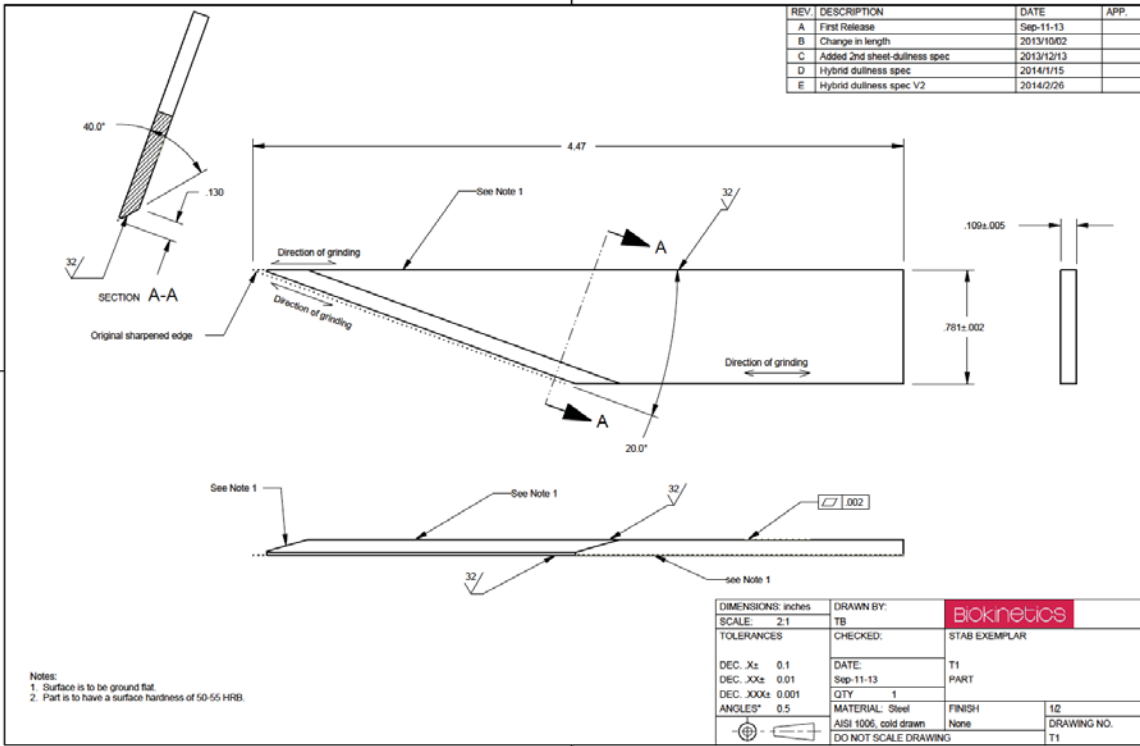

Exemplar T2

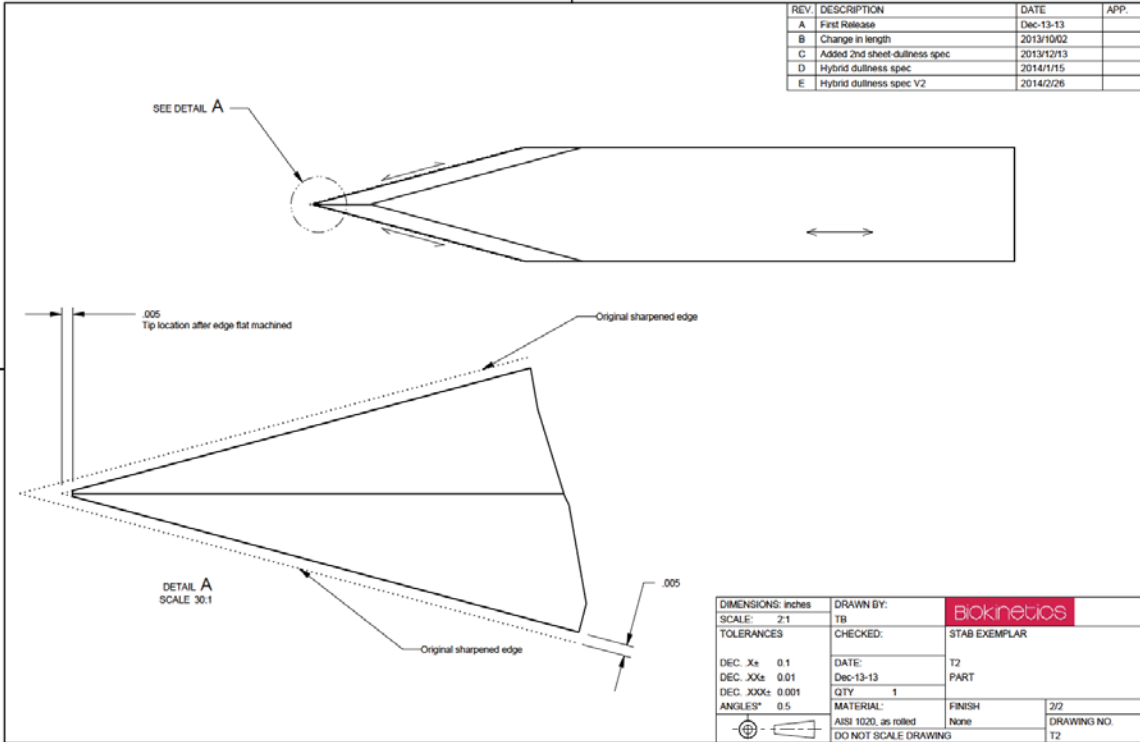
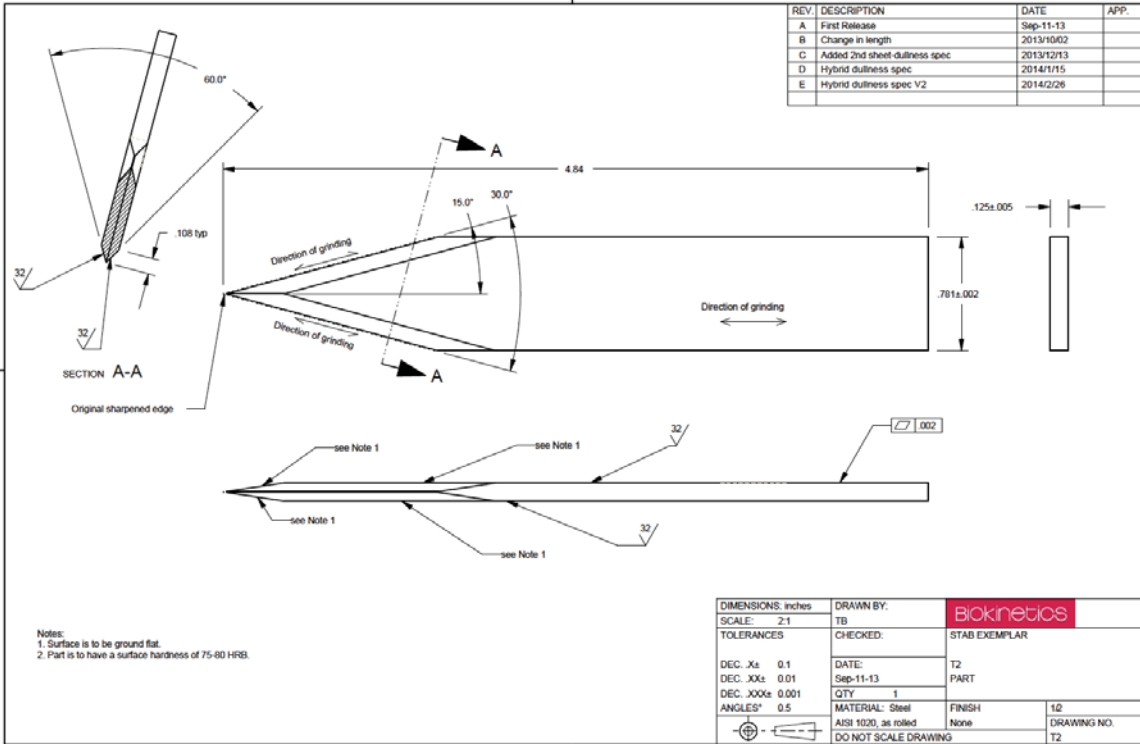

Exemplar T3

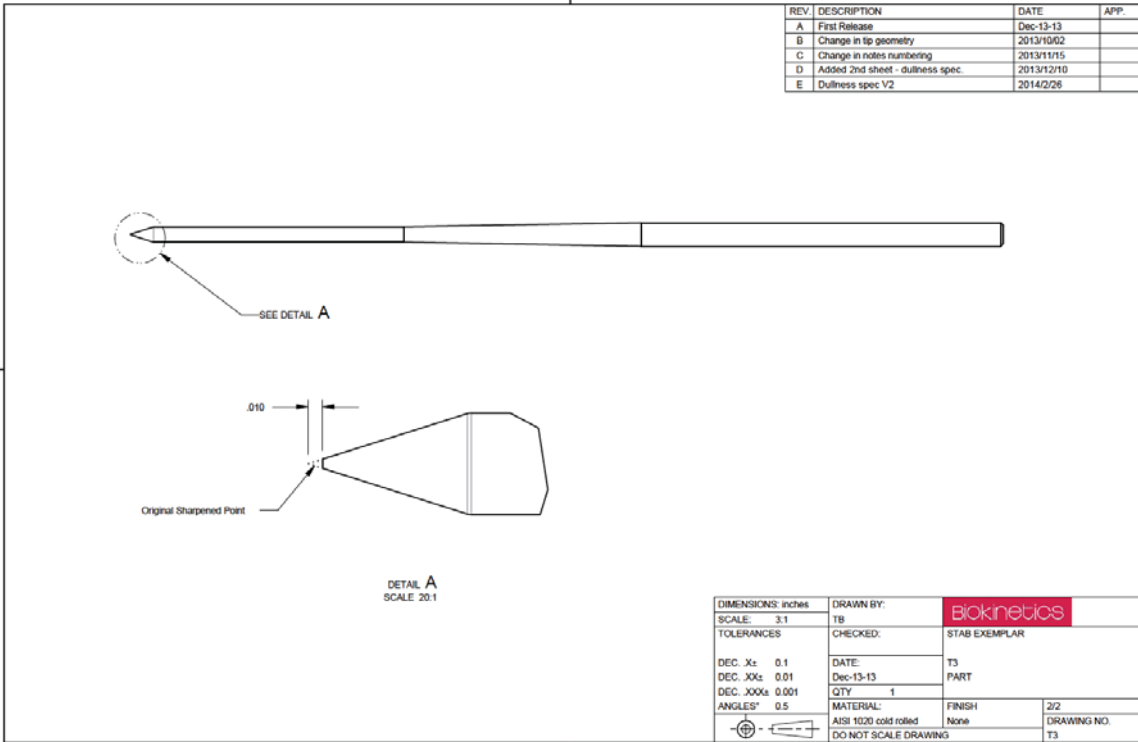
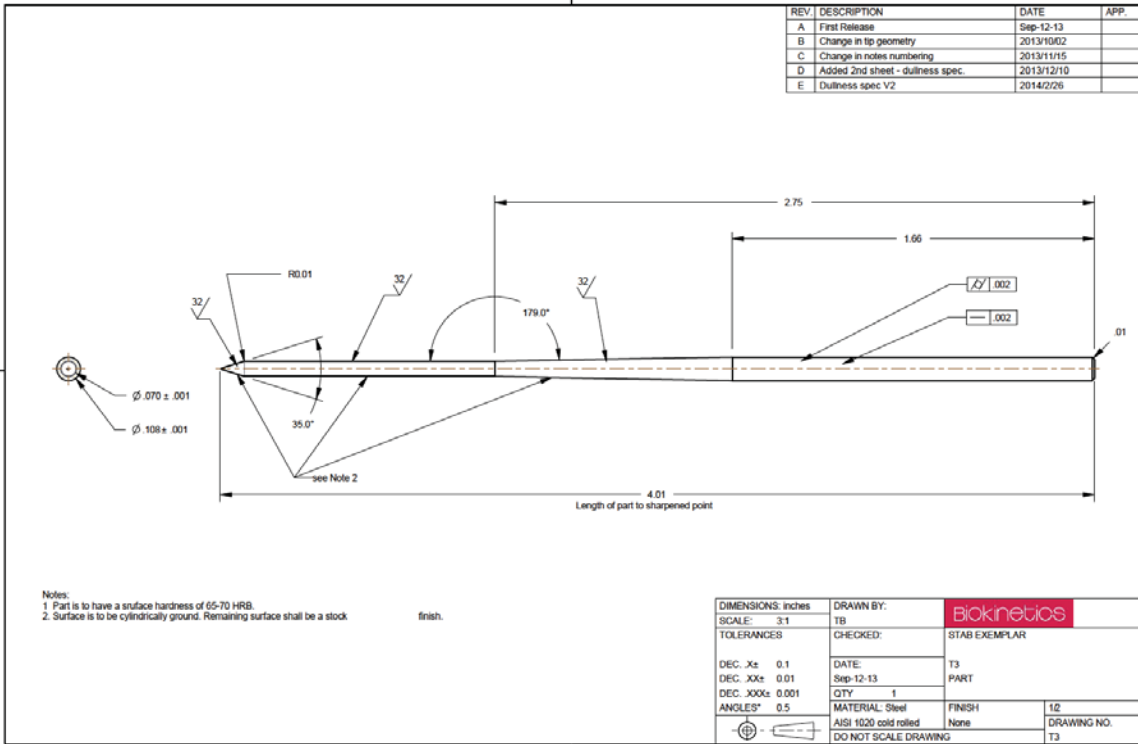

Exemplar T4

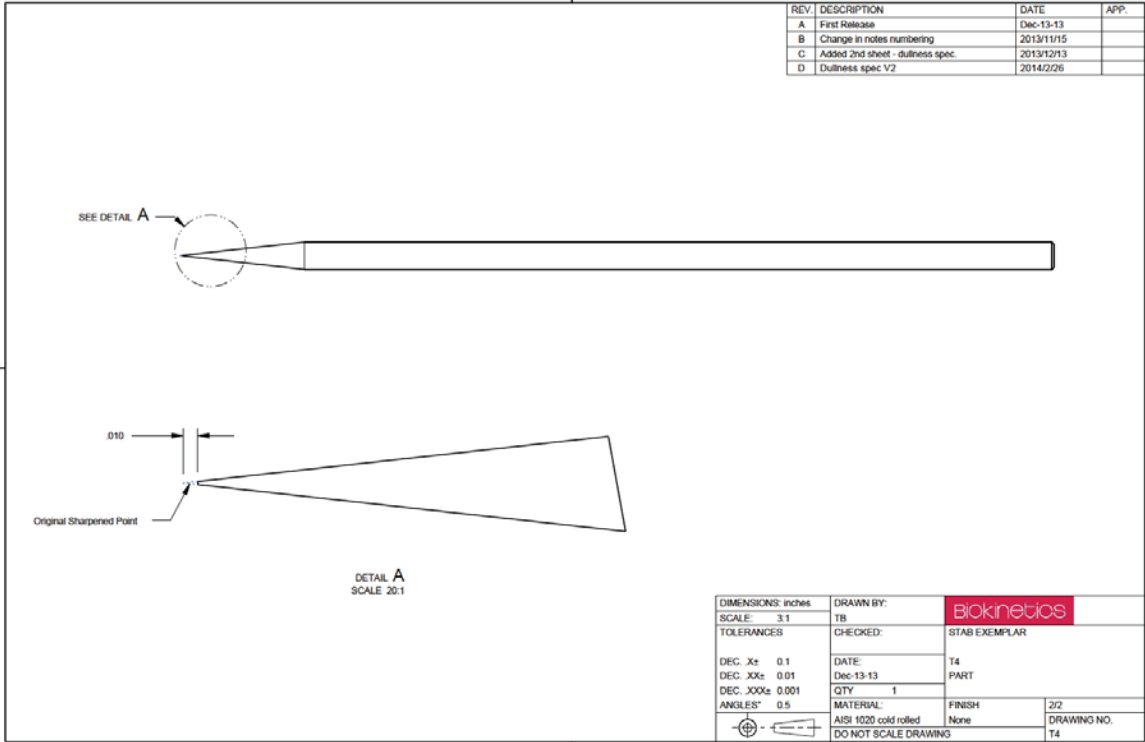
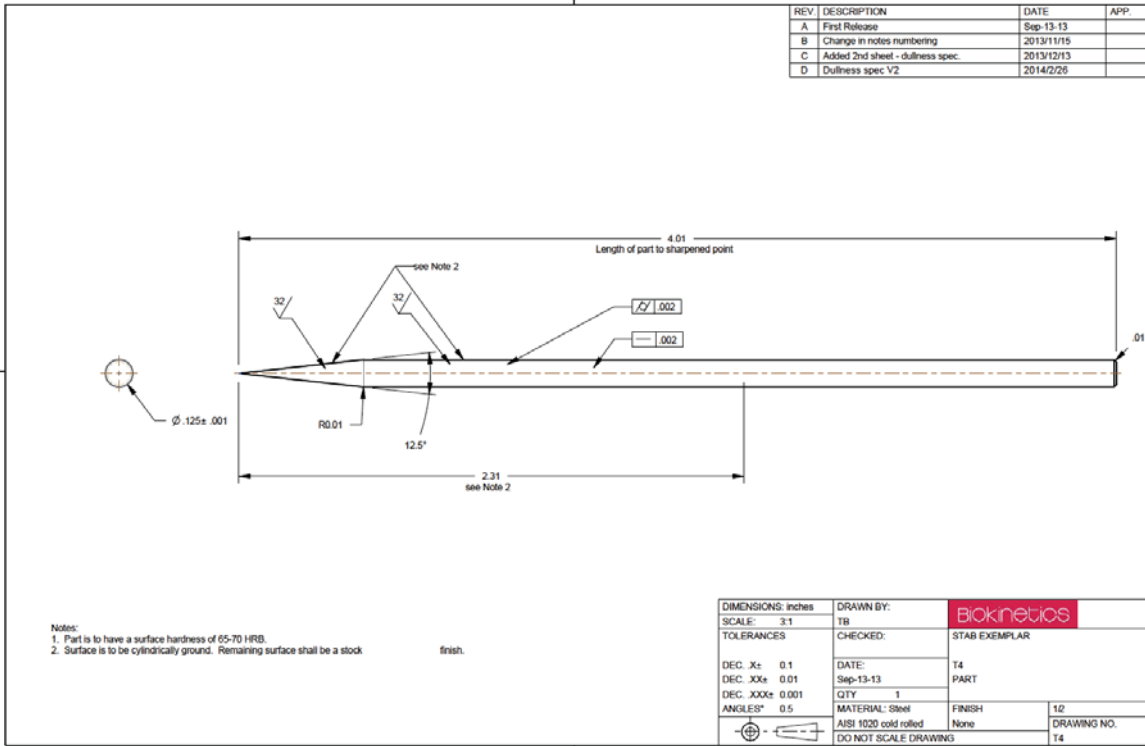

(this page intentionally left blank)