



142948

# **THE IMPACT OF ADA ON CORRECTIONAL DESIGN AND CONSTRUCTION**

by

**Randall Atlas Ph.D., AIA, CPP**

**ATLAS SAFETY & SECURITY DESIGN INC. ®**

**MIAMI, FLORIDA**

**MAY 1993**

This paper is intended to introduce the reader to the Americans With Disabilities Act of 1990 (ADA), and how the Act will most likely apply to detention and correctional facilities. The paper will focus on the types of changes that might be required of jails and prisons, and where those changes might be applied. It will provide readers with basic information on the ADA and will refer them to the ADA Accessibility Guidelines and Statute Section (SS) where appropriate.

State and local governments may not discriminate against qualified individuals who are disabled, and government facilities, services and communications must be accessible in a manner consistent with the requirements of Section 504 of the Rehabilitation Act of 1973 (which covers federally funded recipients) and the ADA. A public entity is any state or local government, any department, agency, special purpose district, or instrumentality of a state or local government. The Federal government and its agencies are excluded from the coverage of the ADA; however, Section 504 does apply to them.

Title II of ADA prohibits a public entity ( government agency ) from denying qualified individuals with disabilities participation in or the benefits of a program or activity it offers

142948

**U.S. Department of Justice  
National Institute of Justice**

This document has been reproduced exactly as received from the person or organization originating it. Points of view or opinions stated in this document are those of the authors and do not necessarily represent the official position or policies of the National Institute of Justice.

Permission to reproduce this copyrighted material has been granted by  
Randall Atlas, Ph.D.

to the National Criminal Justice Reference Service (NCJRS).

Further reproduction outside of the NCJRS system requires permission of the copyright owner.

because its facilities are inaccessible (SS 35.149). Therefore, if a jail or prison offers programs, activities or services in an existing facility, it must ensure that the programs are usable by individuals (staff, visitors, public and inmates) with disabilities ( mobility, hearing, visual, and mental). The focus of Title II is on making **programs**, not **buildings**, accessible. Examples of programs, services, and activities that might normally be conducted in corrections would be: visitation, medical services, recreation, program activities, library, housing, bathrooms, control center, etc.

Unlike public accommodations in Title III, which applies to public accommodations, (hotels, banks, shopping centers ), public entities ( Title II ) are not required to remove barriers from each facility, even if the removal is readily achievable. A public entity, or government building/agency, must make its programs accessible. Physical changes to a building are required only when there is no other feasible way to make the program accessible. If it is possible to provide accessibility through alternative means, structural changes are not required. A public entity is not required to take steps that would fundamentally alter the nature of the program or impose undue financial or administrative burdens. If structural changes are required, public entities must develop a **transition plan** detailing the steps to be taken and a schedule for completion.

The National Institute of Corrections has taken the position in the Small Jail Design Guide, (1988, P. 4-96) that "the needs of the handicapped or non-ambulatory inmate must be accommodated within the housing units." Design characteristics in new construction and alterations/renovations according to ADA (1990) should meet ADA Accessibility Guidelines (ADAAG). Key design elements for consideration are:

1. Doors in the housing areas and cells should be wide enough to allow a minimum clear width of 32 inches, be opened at least 90 degrees, with only five pounds of pressure, using a lever handle for interior doors. The pressure for exterior doors has not yet been officially determined, but it is recommended not to exceed eight pounds of pressure. (ADAAG 4.13)

Opening a 12 Gauge, 500 Pound metal door with 5 lbs. of pressure will be a challenge for the correction's door closer industry. The extensive use of hydraulic or pneumatic door openers is evolving. One common mistake is to plan for a 32-inch- wide door and forget that the door hinges may project into the door frame, yielding an effective width of less than 32 inches. It is recommended that architects specify a 34 inches or 36 inches-wide door. Door hardware, such as locks and door pulls must be mounted no higher than 48 inches. Often, door pulls are mounted higher on the door, so as to not interfere with the locking mechanism. Handles and pulls placement may have to be innovative in their mounting in order to comply with the height limitations.

2. Door closers should be set at a tension level that is usable by persons with disabilities. The time it takes for the door to close must be adjusted so that from an open position of 70 degrees, the door will take at least three seconds to move to a point three inches from the latch. Interior hinged doors should provide for the maximum opening force of five pound feet (lbf). Exterior door closing strength has

not yet been decided by the Guidelines. (ADAAG 4.13.10, 4.13.11)

3. Toilet and lavatory fixtures within an inmate cell or bathroom should accommodate the access needs of the disabled. (ADAAG 4.26) Centralized bathroom and shower areas should be fully accessible. (ADAAG 4.22,4.23)
4. Cell desks and dayroom tables must be accessible. Because fixed stools often do not allow wheelchair access, at least one position at the dayroom tables should be made accessible. This could be accomplished with either a movable chair or a swing-out security type seat.
5. Fixtures in the dayroom or housing areas, such as intercoms, electric lighters, wall plugs, microwaves, fire alarm pull stations, vending machines, and telephones must be accessible as per the ADA requirements. (ADAAG 4.27.3)
6. All elevator controls need to be readable in braille and at the proper height. ( ADAAG 4.10.7) Fire alarms may need to be expanded to install flashing alarm lights. (ADAAG 4.28)
7. Reduce door thresholds; install accessible door hardware in place of round knobs. (ADAAG 4.13.8, 4.13.9) Remove high-pile low-density carpeting. (ADAAG 4.5.3)
8. Position some telephones lower; provide telecommunication display devices (TDD) on the telephone banks. (ADAAG 4.31) ADAAG states that a Text Display Device (TDD) must be provided inside a building that has at least one interior pay phone and four or more public pay phones. (ADAAG 4.1.3(17)(c))
9. Provide for some percent of housing to be dedicated as accessible cells. ADAAG has not determined the scoping requirements indicating how many cells need to be accessible or their distribution within a facility. Accessible housing must be provided in an integrated setting in order to lesson the distinction and separation of disabled individuals.

A common question that is asked is if there is a dedicated "disabled persons unit" can all of the disabled inmates be housed there? The answer is **NO**. It is clearly a discriminatory practice to classify the inmate based on disability as it would be to separate them based on color. There are numerous examples of special housing units that are trustee units, or therapeutic communities, or alcohol drug abuse units. If those special units have physical or communication barriers that prevent inmates with disabilities from participating in them, then the result is a violation of the ADA and policy of discrimination. Likewise, if a prison or jail has 1000 beds of general population medium custody cells, having an accessible unit dedicated to individuals with disabilities would be appropriate. The key is that a small proportion of every type of classification, (and the resulting programs), should be barrier free.

10. Special compliant building signage will have to be provided on all permanent

rooms. Signage must have the proper background contrast, with letters raised 1/32 of an inch, and have the braille translation underneath. Signage must be 60 inches above the floor and placed adjacent to the latch side of the rooms door. (ADAAG A4.29, 4.30)

There are many areas within a correctional environment that would have programs or activities with accessibility concerns. Examples of areas that could apply are the central control functions, security vestibules, intake and release areas, housing units, health care, visiting areas, program and recreation, food service, laundry, and administrative, staff areas, public and reception areas.

### **CENTRAL CONTROL ROOM**

The ADA would apply to the **central control room** in the design of the work counter, and the control equipment would need to be within the reach limits, which if the control room floor is elevated, there must be an accessible ramp for entry. It is common practice to use disabled officers in control rooms, since there is no direct contact with inmates. (ADAAG 4.32)

### **SECURITY VESTIBULES**

**Security vestibules** should comply with the following ADA standards:

- 1) All control devices must be within the specified height range.
- 2) The minimum space between two hinged or pivoted doors is 48 inches plus width of the door swinging into the vestibule. Doors in series must swing either in the same direction or away from space between doors.
- 3) Thresholds at the doorways shall not exceed 3/4 inch for exterior sliding doors and 1/2 inch for all other type of doors. Thresholds and floor level changes must be beveled with a slope of 1:2. (ADAAG 4.13.8, 4.5.2)
- 4) Door hardware must be in a shape that can easily be grasped with one hand, such as a lever-operated, push-type, and U-shaped handles. (ADAAG 4.13.9)
- 5) Round door knobs are no longer allowed in any application. Automatic door openers are acceptable. When sliding doors open, the hardware must be exposed and usable on both sides of the door and mounted no higher than 48 inches.
- 6) Door closers for swinging doors must be adjusted so that the door takes at least three seconds to move from 70 degrees open to a point of three inches from the latch.
- 7) Sliding doors shall have a maximum force of opening of 5 lbf. Automatic doors shall not open to back check faster than three seconds and require no more than 15 lbf to stop. (ADAAG 4.13.12)

## INTAKE AND RELEASE AREAS

Intake and release areas would require:

- 1) The path from the vehicle sallyport area to the booking area must be through an accessible. There should be no door thresholds that could provide tripping hazards, and the door system must meet ADA requirements.
- 2) Once in the booking area the search/pat-down area should be accessible, along with the fingerprinting, photographing, medical screening, and holding areas.
- 3) If the arrestee has access to a telephone area with more than 4 telephones, one of the phones will need to be a TDD, and lowered to 36 inches in height. At least one arrestee phone should be adaptable to use a TDD regardless of the number of phones. Even if there is only one phone, it should be adaptable to receive a TDD. In a small jail, the arrestee does not have an option to leave and get another phone in another location.
- 4) The arrestee toilet should meet the standards, yet should also be suicide-proof. If the toilet area is open for visual and audio supervision, then the inmate can be observed if they try to hang themselves or tamper with the grab bar. However, if the toilet area is private and directly observable then grab bars in the toilet should be **adaptable** to receive grab bars so they are not used as a weapon or suicide opportunity. One solution is to alter the grab bars with shields that provide a barrier from the grab bar to the adjoining wall which will prevent tying off any device such as a shirt or shoe string to hang from. ( See SKETCH # 1 )
- 5) The shower area floor surface must be flush to the floor. No floor threshold greater than 1/2 inch is permitted by ADA to allow entry into a shower by a wheelchair.
- 6) All countertop work areas, such as interviewing, fingerprinting, medical screening and property storage should have a portion of the countertop at the maximum height of 36 inches, and at least 36 inches in width. Release activities should permit full accessibility. Work counters, shelving for forms, telephone banks, and property storage should meet ADA standards. If shelving for property storage is going to exceed the maximum height allowed (54 inches), it is recommended that this issue be addressed in the required ADA Audit/Self-Evaluation Survey. Operationally there may a disabled staff person working in property storage; however, a fully able staff person must be available to provide assistance for higher shelf access when needed.
- 7) Record storage would also need to comply with shelf height requirements and minimum corridors width.

# GRAB BARS - FIGURE 1

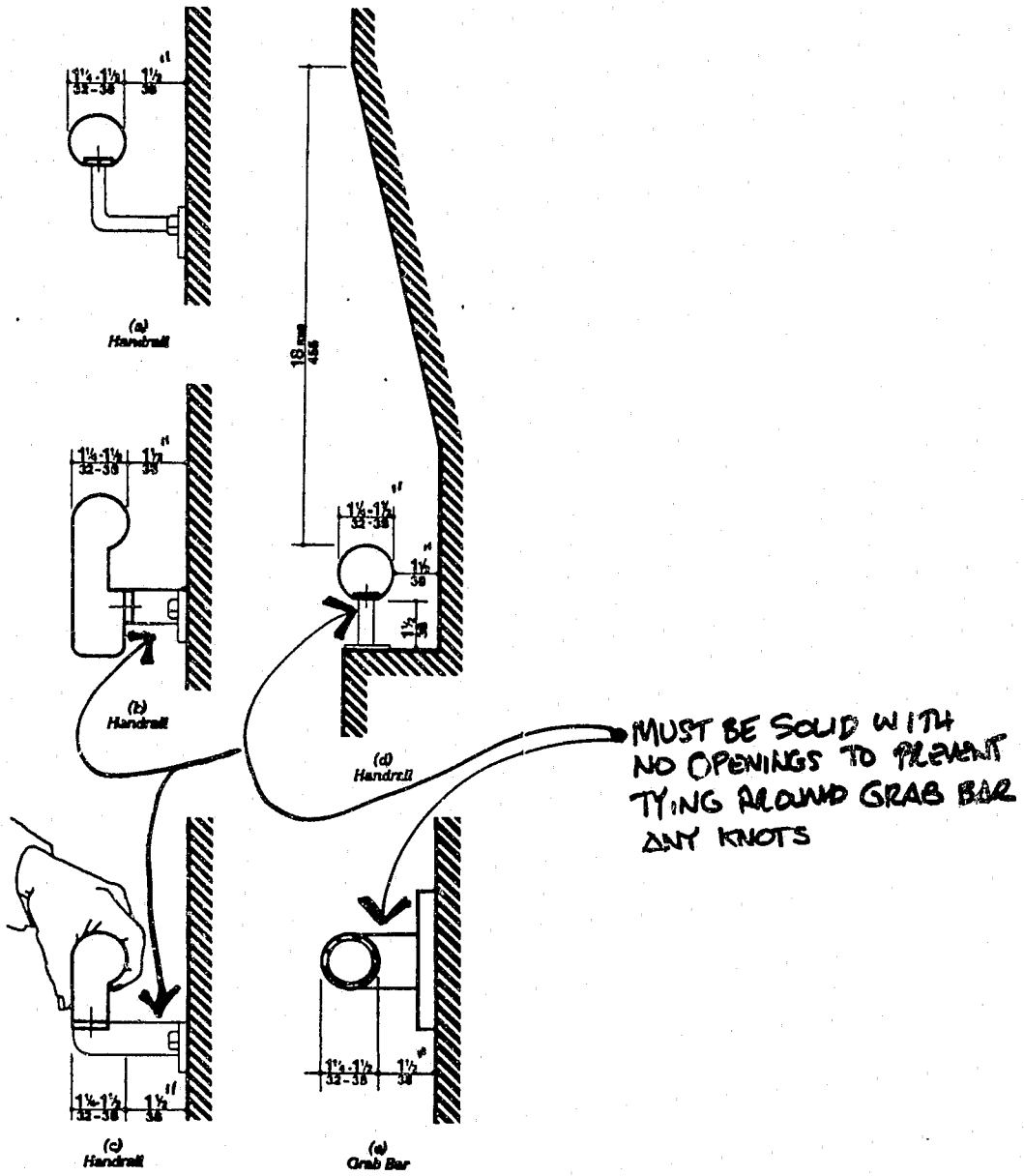

## HOUSING AREAS

**Housing areas** have special needs for accessibility, including:

- 1) ADAAG has no scoping requirements indicating how many cells need to be accessible. While the Uniform Federal Accessibility Standards (UFAS) regulation require a minimum of 5 percent of resident housing would need to be fully accessible ( SS 4.1.4 (9)(c)), the proposed Title II ADAAG regulations have not made a final determination.
- 2) It is recommended that one or two cells per housing pod (up to 64 persons) be designated as accessible cells. The walls must be designed to receive grab bars. The cell must have the proper turning radius and door clearances. It should have a raised toilet 19 inch from the floor and the ability to put in grab bars that will support 250 pounds per square foot, and all desks, chairs and control fixtures should meet ADA standards. ( See SKETCH # 2 )
- 3) If grab bars are to be placed in a single cell, there is a potential direct threat of inmates making weapons, or committing suicide by hanging from the bars. Just as many single cells have anchors attached to the wall for future double bunks, anchors can also be preset in the wall to accept grab bars, if and when the need is present. An alternative to wall anchors is to have the wall area around the toilet constructed with a double layer of exterior type plywood anchored to the block, concrete, or steel wall surface. If grab bars would need to be installed, they could be attached using long wood screws, with the plywood providing sufficient structural strength to support 250 pounds. It is also possible to make alterations to the grab bars, such as tack welding a screen or piece of sheet metal to close the gap between the bar and the wall. If a knot can not be secured around the bar, hanging is not possible. If an inmate cell is being formed out of concrete it is possible to form the bar as an indentation from the walls adjoining the toilet. As a one-piece form, the grab bar would not have an opening through which inmates hang themselves.
- 4) Showers in the housing areas should be fully accessible, with fixture height no greater than 48 inches, and no lip greater than 1/2 inch to catch the water. Carefully placed floor drains and sloping floors must be added to direct the flow of water spray. The ADA also specifies the maximum angle of slopes to be 1:16 to 1:20 and recommends a minimum 0.6 Coefficient of Friction for floor surfaces.<sup>1</sup> A typical shower stall in a correctional facility is 36 inches by 36 inches. ADA requires such shower stalls to have a mounted seat that extends the full depth of the stall. All controls, faucets and shower units are to be mounted on the side wall opposite the seat. A shower stall 30 inches by 60 inches does not require a fixed seat. ( See SKETCH # 3 )

---

<sup>1</sup> The Coefficient of Friction is the point at which two surfaces in contact with each other begin to move and overcome friction.



# ADA ACCESSIBLE CELL

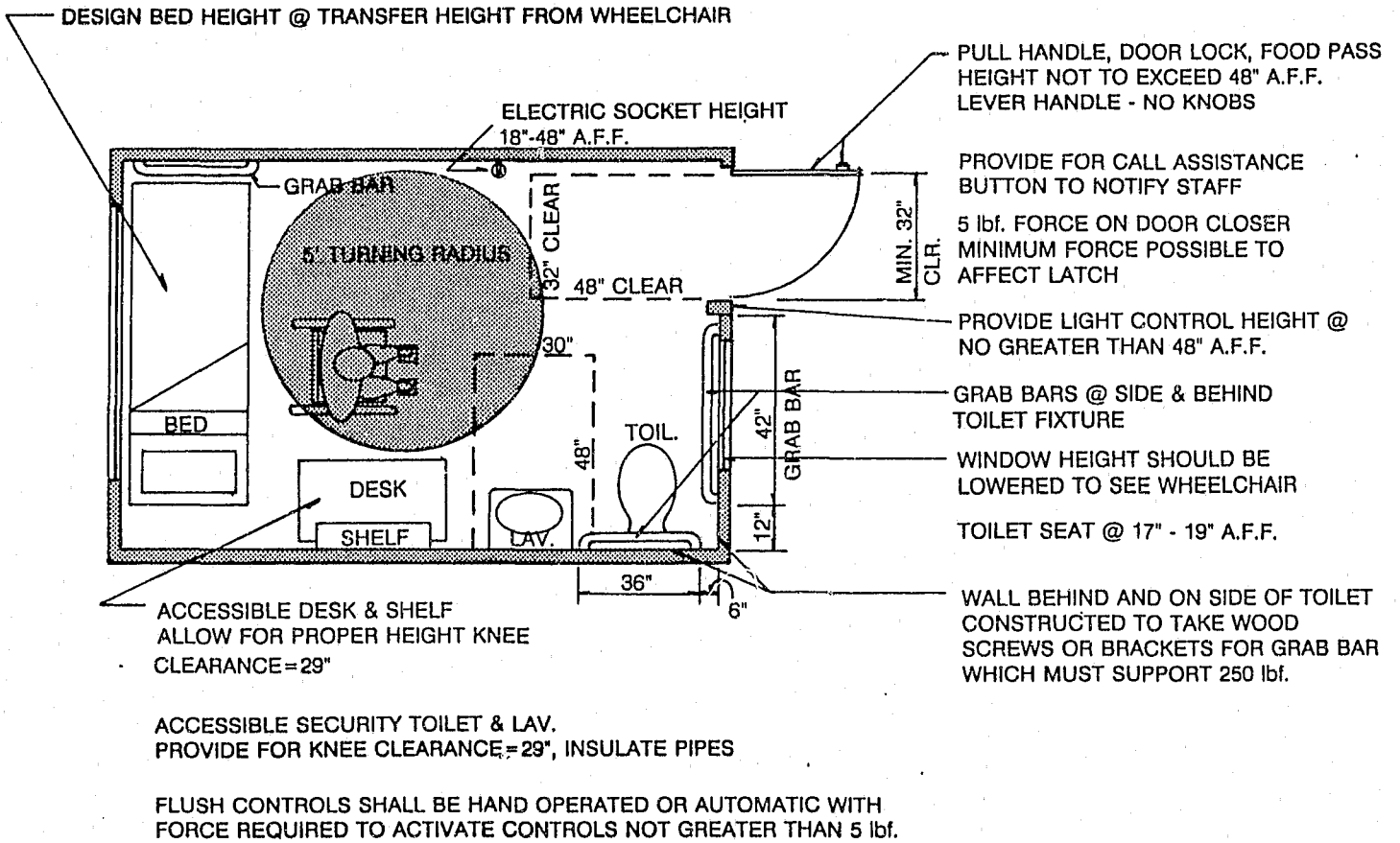
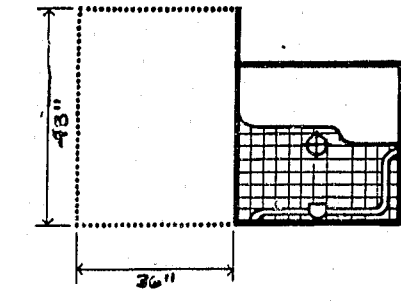

FIGURE 2

- 5) Housing unit bathrooms will need to be fully accessible. It is important to provide enough room under the sink countertop for a person to be able to pull a wheelchair up under the sink. ( See SKETCH # 4 ) Pipes must be insulated so as not to expose a burning danger to wheelchair-user inmates. If there are up to five toilets, one of them must be a standard ADA stall (ADAAG 4.17.3). However, if there are six or more toilets, in addition to the standard ADA stall, at least one of the remaining five stalls shall be exactly 36 inches wide by 60 inches long with an out-swinging, self-closing door and parallel grab bars complying with ADAAG 4.26.
- 6) If activities occur on the mezzanine level that require access, such as non-contact visiting, the mezzanine must be made accessible. If the only access for inmates and staff to get from the lower level to the mezzanine are the stairs, then all activities must be made available to inmates on the level where disabled inmates could be housed ( most likely on the lower level ), or a mechanical lift must be provided to get persons from the lower level to the mezzanine level. Another possibility is to design the elevators to stop at all floors. However, elevators that carry civilians and inmates together may be considered a security breach. The solution lies in the ability, or flexibility, to solve the problem architecturally or procedurally.
- 7) ADAAG 4.9.2 states on any given flight of stairs, all steps shall have uniform riser heights and tread widths. **Open risers are not permitted.** Open risers are a commonly used design tool to allow the officer to have clear, unobstructed supervision through the stairs, thus preventing a blind spot. One way to architecturally solve the open riser problem is to provide a wire mesh screen as the back of the riser. The mesh would allow visibility through the stairs, yet prevent the possibility of slipping through the stairs.
- 8) Dayrooms that are mid-level in a split-tier housing arrangement must be accessible to those on all housing floor levels. This condition might require a ramp or hydraulic lift that could raise or lower a wheelchair.
- 9) Officer workstation and desks need to be accessible. It is likely to be the policy of the corrections department, currently, that officers with disabilities can not work the housing units because of the likelihood of "direct threat" of harm to the officer, especially in a disciplinary situation. However, future litigation probably will establish the rights of handicapped staff to work in housing units. The staff toilet in the housing unit must be accessible, even though there may be no disabled officers in this vicinity, because of the standard that all areas be accessible for new construction.

## **MEDICAL AREAS**

The **health care, clinic, infirmary, medical isolation, sick bay**, and other **medical** areas would be required to be in full compliance with the ADA and consider the following items:



36" by 36" Stall

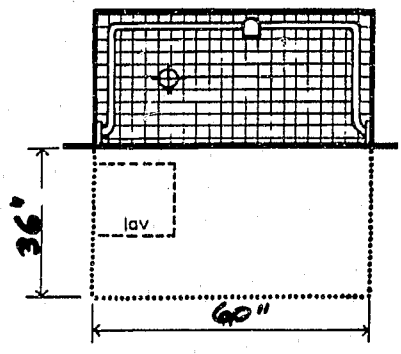

30" by 60" Stall

FIGURE 3

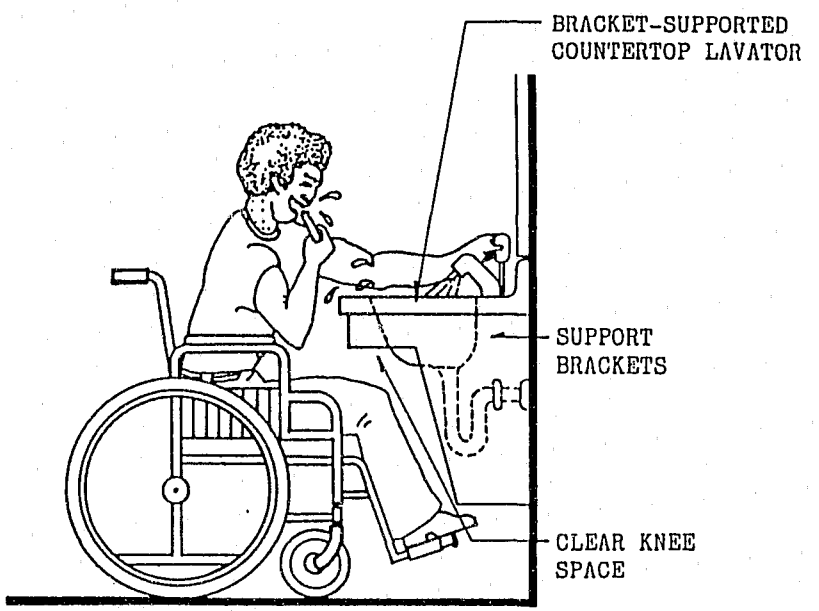

ANSI AND UFAS REQUIRED CLEAR KNEE SPACE AT LAVATORIES

FIGURE 4

- 1) Exam rooms should have doors wide enough for wheelchairs and stretchers.
- 2) Countertops and work surfaces should have a portion that is 36 inches in height and at least 36 inches in width.
- 3) Medical storage areas, staff work areas, toilet facilities, records areas, doctors offices, nursing stations, medical dispensary, and inmate waiting areas all should meet the various requirements for accessibility.

## **VISITING AREAS**

**Visiting areas** have to be accessible to the visiting public and inmates.

- 1) When the visiting is centralized or decentralized, the public path of travel from the outside of the building through to the visiting area, along with adjacent spaces such as public bathrooms, visitor screening, vending areas, lockers, and waiting areas all must meet the ADA standards. (See SKETCH # 5)
- 2) If the only access for a visitor is through a metal detection machine, it must be widened to allow a clear width of 32 inches. If there is an alternative path for a mobility impaired visitor, they can be manually searched by a hand-held detector that allows for a procedural alternative.
- 3) If a metal detector passage is wide enough for wheelchair access through, the metal wheelchair sets the machine off. One innovation that may be generated from implementation of the ADA is the development of an all-acrylic wheelchair for weapons screening of disabled persons through metal detection devices.
- 4) When contact visiting is available, careful attention should be paid to the tables and chairs that are used by inmates and visitors. Tables and chairs should permit accessibility from a wheelchair. Non-contact visiting often happens in small partitioned booths with inmates and visitors shouting at each other over a phone device or through metal screening. It is recommended, that some, or at least one, of the non-contact booths be designed for a wheelchair to be able to slide underneath. Clearance under a table or counter should be 27 inches to allow knee clearance. Counter top should be at least 36 inches in width and no higher than 36 inches high. The counter should extend a minimum of eight inches from the partition.
- 5) It is recommended that at least one of the visiting booths have a TDD for hearing impaired inmates or visitors. Often visitors must fill out forms at a visitor reception desk.
- 6) A portion of the reception desk should be no higher than 36 inches in height. Visitor waiting areas, which include restrooms, telephones, drinking fountains, and locker storage areas, must be fully accessible.
- 7) If visiting is located at the housing units, the travel path to the visiting areas must

# ENTRANCE

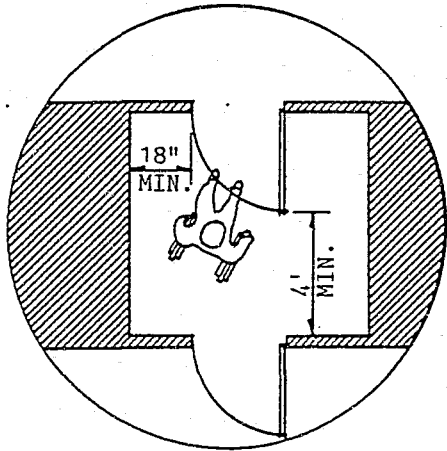

PLAN AT VESTIBULE

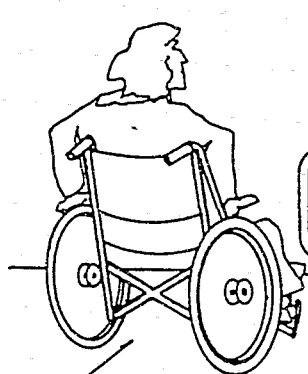
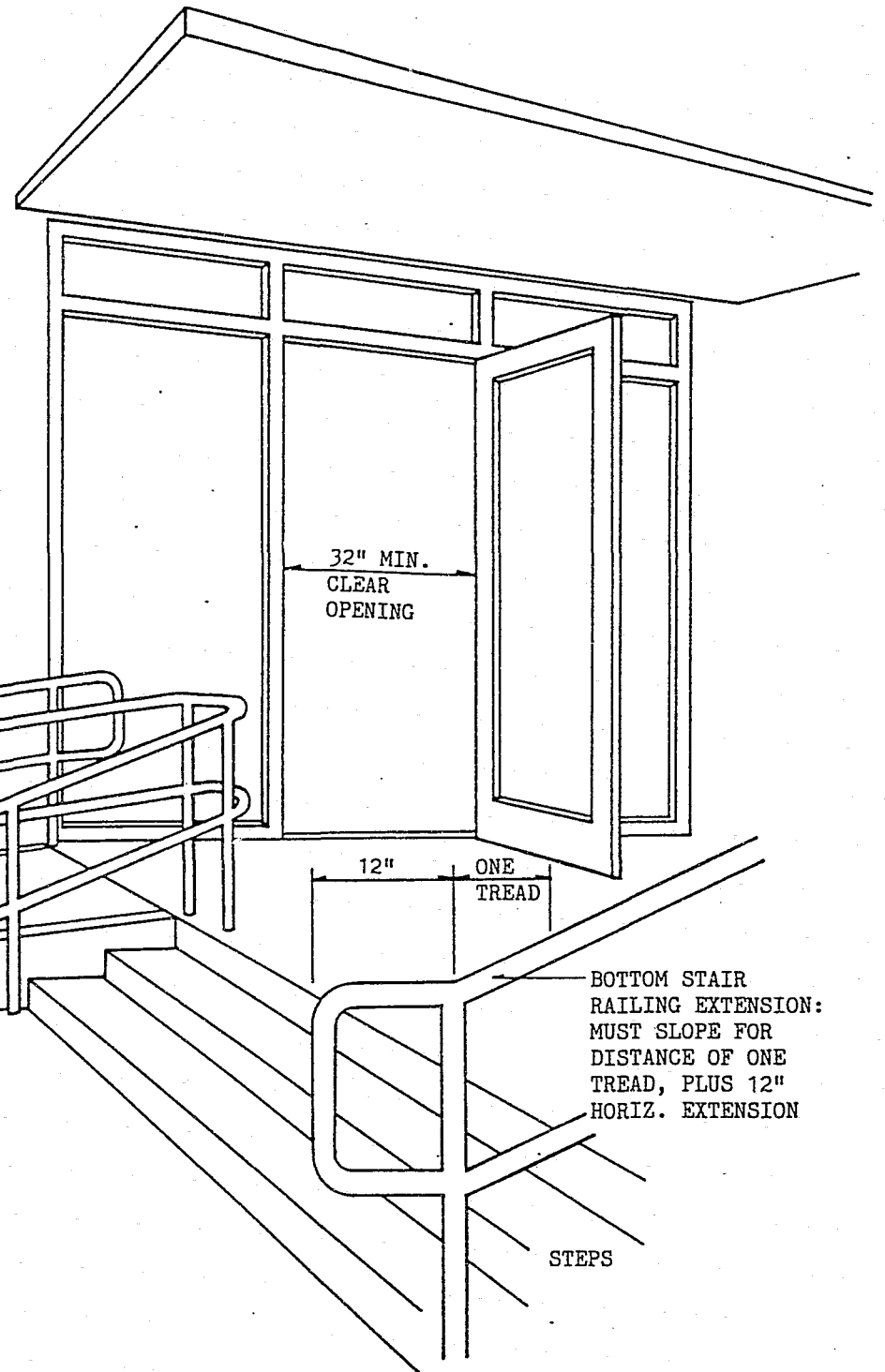

60" x 60" MIN. LANDING  
REQUIRED WHERE CHANGE  
OF DIRECTION OCCURS

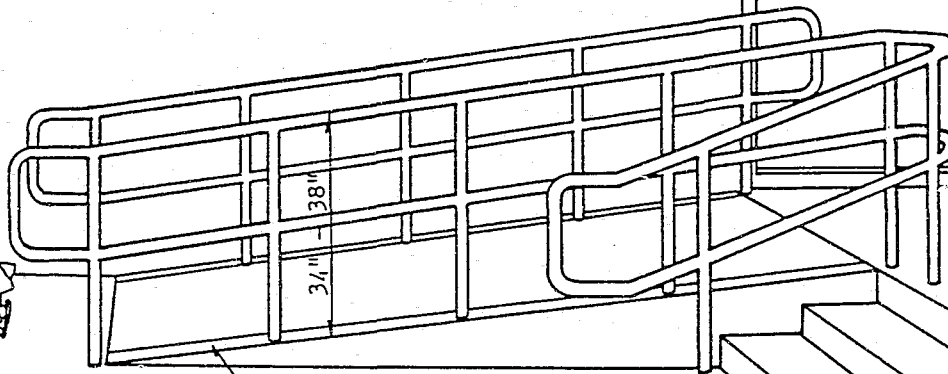

EDGE PROTECTION  
RAMP

12" ONE  
TREAD

BOTTOM STAIR  
RAILING EXTENSION:  
MUST SLOPE FOR  
DISTANCE OF ONE  
TREAD, PLUS 12"  
HORIZ. EXTENSION

STEPS

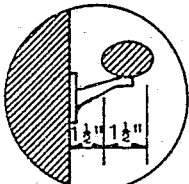

RAILING

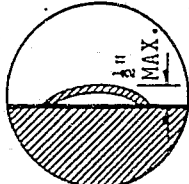

THRESHOLD

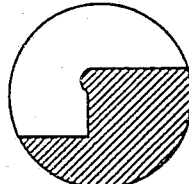

NOSING

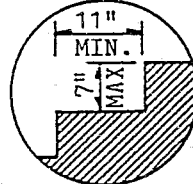

STAIR RISE &  
TREAD

# SITE

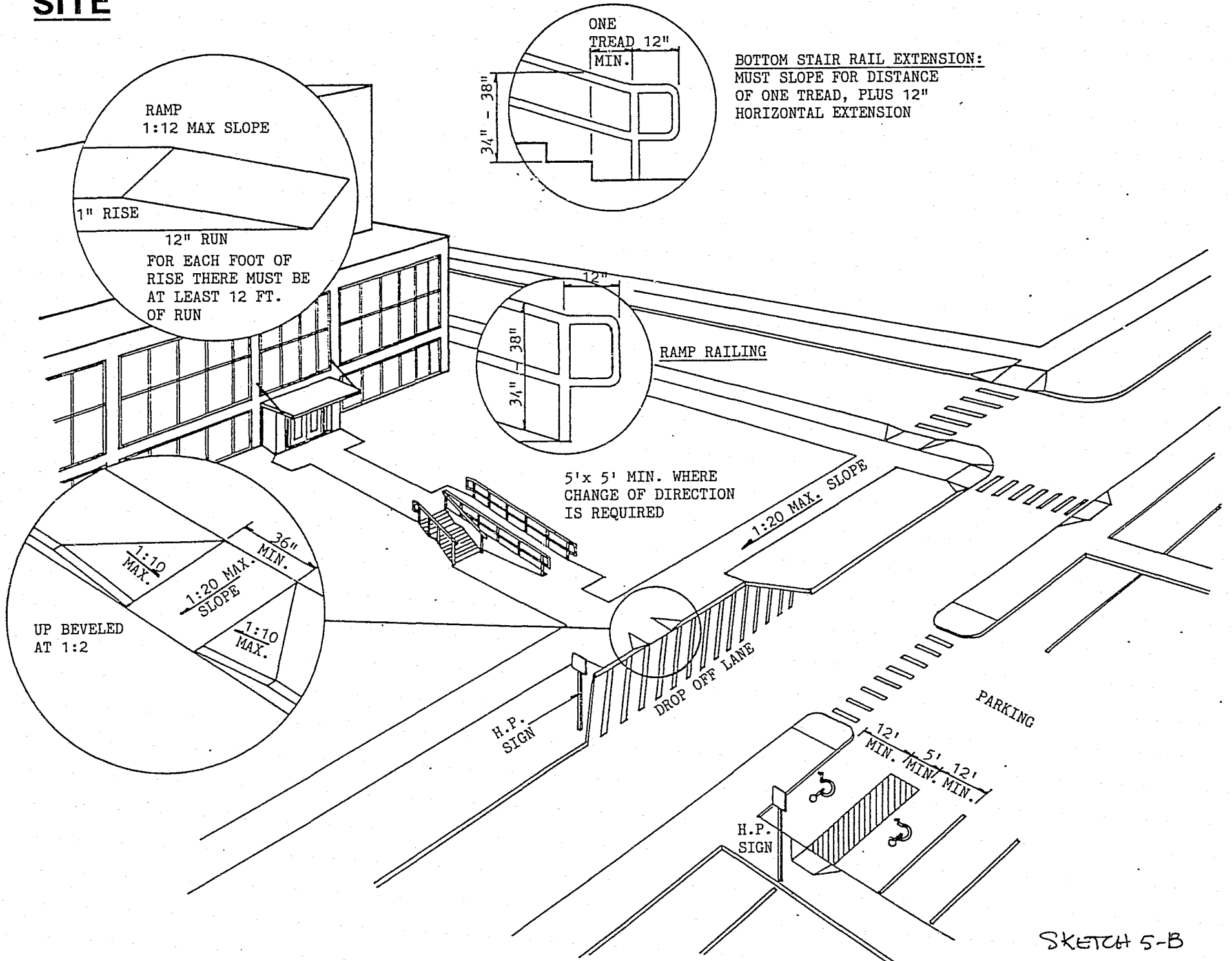

SKETCH 5-B

# BUILDING

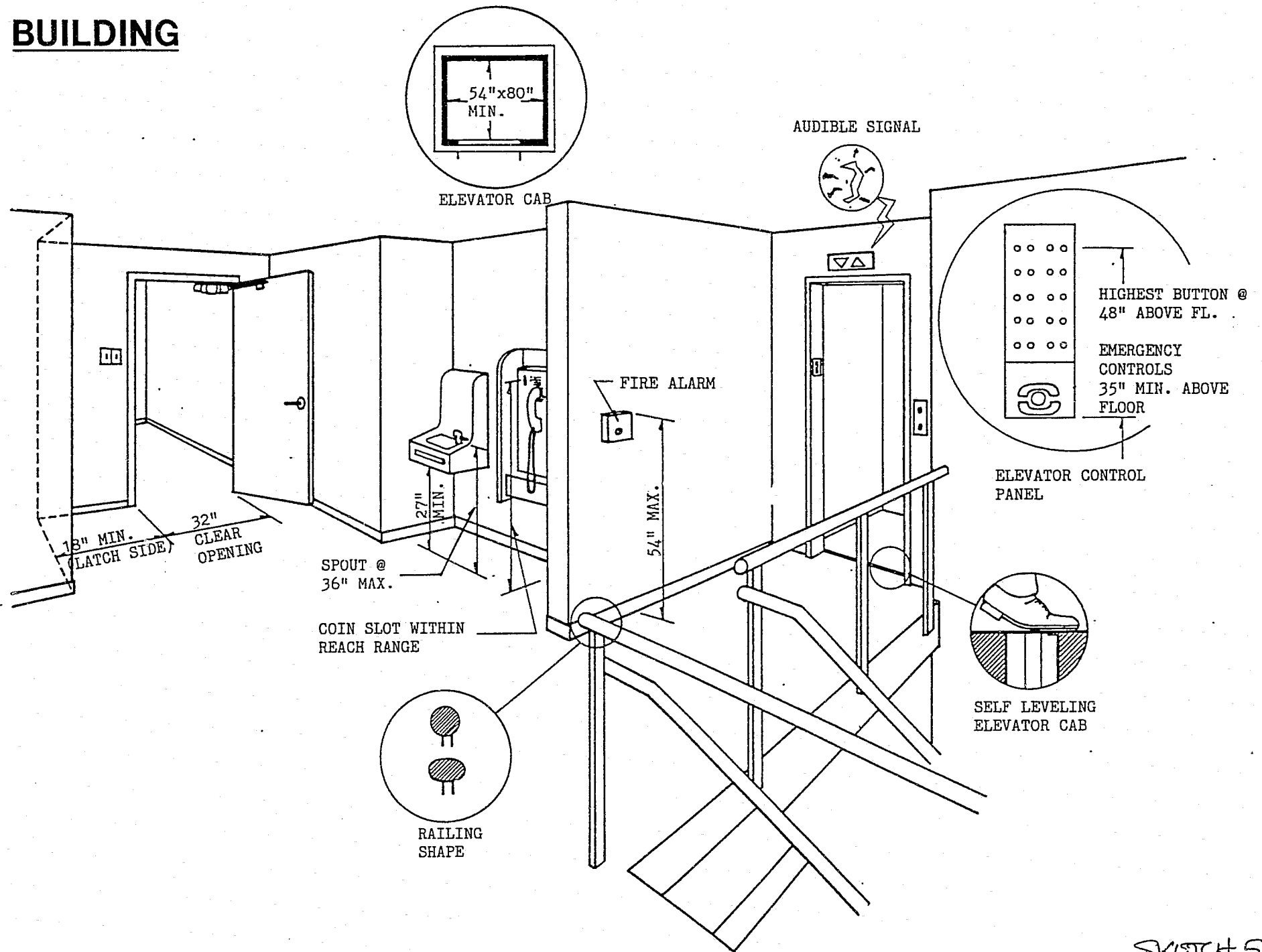

SKETCH 5-C

be fully accessible and provide for ADA acceptable door widths, door thresholds, door closers, signage, and elevator controls.

### **PROGRAM SERVICE AREAS**

**Exercise areas (indoor and outdoor), multipurpose areas, program services, and the inmate commissary** must provide a number of measures to ensure accessibility:

- 1) All exercise and multipurpose areas, door widths, door thresholds, door closers, door knob hardware, water fountains and bathrooms, should be made fully accessible.
- 2) In the design and planning of program service areas, such as religious areas, chapels, assembly rooms (for inmates or staff), counseling areas, group therapy areas and libraries, these spaces must be made fully accessible. Since program areas are gathering areas for groups of inmates, it is required that visual and audible fire alarms and public address systems be designed into each space.
- 3) It is possible that a handicapped staff person could be working in the commissary or canteen, so work surfaces, shelf heights, window pass through, dutch doors, and controls for all devices ( e.g., an electric overhead rolling shutter window ), shall meet the ADA standards.

### **FOOD SERVICE AREAS**

**Food service areas** also will need to meet certain accessibility requirements:

- 1) Food and beverage preparation, cleanup and dishwashing areas usually occur in the heart of the kitchen. Widths of corridors should allow ease of moving around.
- 2) Dry storage, freezers, waste disposal and cart storage area door widths usually are designed for movement of rolling carts and dollies, and thus already meet many of the ADA requirements.
- 3) Visual and audio fire alarm systems must be located within the food services areas.
- 4) Staff dining rooms or cafeterias need to comply with ADA standards. The kitchen managers office and staff toilets also need to comply.
- 5) Shipping and receiving areas would most likely not be accessible areas. These openings in the building are not public entrances, and thus not necessarily accessible to handicapped persons.



## **LAUNDRY AREAS**

Many jails and prisons have **laundry** facilities. Sometimes the laundry is decentralized, with washing and drying machines located in the housing units for personal laundry. Some facilities handle institutional laundry and inmate personal laundry from a centralized area. Laundry services must be located in a way that ensures adequate security requirements yet provides appropriate access by inmates.

- 1) Most functions in a laundry area, such as linen and clothing storage, ironing and pressing, supply storage, laundry carts, folding tables, dry cleaning, and washing and drying occur in a large dedicated area.
- 2) Water fountains, fire detection and alarm devices, non-slip floor surfaces, no protrusions of greater than four inches, and work counter heights would need to comply with the ADA.

## **ADMINISTRATION AND PUBLIC RECEPTION AREAS**

**Administrative and public reception** areas accommodate the public's need for access to the facility and to gain information about inmates and other aspects of jail or prison operation.

- 1) The most common areas that would be affected by the ADA are the public lobby, reception/information desk, conference and meeting rooms, clerical work areas, staff break room, records storage, supply storage, staff toilets, staff parking areas, public toilets, and waiting areas. Typical ADA standards that would apply to these spaces are signage requirements, arrangement of furniture; height of bulletin boards, telephones and drinking fountains; restrooms; fire detection/alarm systems; countertop heights; door widths; door thresholds; and door hardware.
- 2) The armory and security equipment storage would need to be accessible.
- 3) Mechanical rooms, non-occupiable spaces accessed only by ladders, catwalks, crawl spaces, or freight elevators, and used only by service personnel for repair purposes do not have to meet ADAAG standards.

## **STAFF AREAS**

**Staff areas** often include staff parking, staff entry, staff lockers/ showers/ bathrooms, staff exercise areas, briefing or muster rooms, staff break rooms, and staff dining areas. A new facility would need to design for:

- 1) All staff areas need to be handicap accessible.
- 2) The showers would need to be designed with no lips, a mounted bench, and grab rails.
- 3) The bathrooms and corridors must be designed so that they are wide enough to

allow wheelchair turning radius.

- 4) Water fountains, door widths and hardware, telephones, shelf heights, countertop heights, and protrusion-free paths of travel must be designed into the facility.
- 5) Staff break areas typically have a countertop for microwaves, coffee makers, and toasters. This counter would need to be at a 36 inches in height and minimum of 36 inches in width.

## **WHAT THE PROPOSED TITLE II RULES FOR JAILS & PRISONS WANT -**

The Americans With Disabilities Act of 1990 (ADA) extends comprehensive civil rights protection to individuals with disabilities. Title II of the ADA, which became effective on January 26, 1992, prohibits discrimination on the basis of disability in services, programs, and activities provided by state and local government entities. On July 26, 1991, the Architectural and Transportation Barriers Compliance Board (Board) published the Americans With Disabilities Act Accessibility Guidelines (ADAAG) to assist the Department of Justice in establishing accessibility standards for new construction and alterations in places of public accommodation and commercial facilities (Title III).

When the Department of Justice published its Title II regulations, it noted that the Board would be supplementing the ADAAG in the future to include guidelines for state and local government facilities. It also anticipated that the Department of Justice would adopt ADAAG as the accessibility standards for state and local government facilities. Adopting the same accessibility standard for Title II and III of ADA will ensure consistency and uniformity of design in the public sectors throughout the country.

The federal agencies responsible for using accessibility standards under the Architectural Barriers Act will adopt standards consistent with ADAAG and supplemented in place of the Uniform Federal Accessibility Standards (UFAS). Title II facilities used to be able to choose between the UFAS or ADAAG, but the Board believes in using ADAAG, and not the continued provision of UFAS.

The proposed Title II amended regulations state that correctional facilities will comply with the applicable requirements of ADAAG 4.1 - 4.35 ( formerly Title III type requirements under ADAAG ) unless specifically excepted in the proposed regulations. What the proposed rules specifically ask for are:

1. At least one secured entrance ( used only by inmates and correctional staff) must comply fully with ADAAG requirements.
2. When security screening systems are located at public entrances, an accessible route shall be provided adjacent to security screening devices to allow a clear path of travel.

**EXCEPTION:** Doors assigned to be operated only by security personnel shall be exempt from the ADAAG door requirements.

3. Visiting areas (non-contact visiting) where provided shall be accessible and located on an accessible route (travel path).
  - a. If fixed visiting cubicles are provided, at least 50%, but not less than one shall comply with counter height and length requirements of ADAAG 4.32.
  - b. Solid partitions or safety glass operations shall permit accessible communications (ADAAG 7.2.3).
  - c. Accessible cubicles or counters shall be identified on each side with the International Symbol of Accessibility.
4. Consideration should be given to the placement of grills, talk through baffles, intercoms, headsets, and other communication devices usable from a fixed seat and from an accessible seating area.
4. No decision has been made on the percentage or number of accessible cells or their dispersion throughout the institution. An educated guess and recommendation is to disperse the accessible cells throughout the facility and provide at least one accessible cell per housing unit ( with rooms or cells ) at each major classification level. Open dorms are basically accessible by their inherent design. Just make sure the bathroom, telephones, and program areas are accessible.
5. Medical care facilities within detention or correctional environments shall comply with applicable ADAAG requirements (Section 6).
6. When cells or rooms are altered in an existing facility, a percentage of new construction shall be made accessible. Though the percentage of new construction has not been determined officially yet, plan for at least a minimum of one per unit.
7. Accessible cells or rooms shall be on an accessible route or path of travel complying with ADAAG 4.3. At least one of each type of common area, amenity, space or element provided for other housing cells in the same classification of housing shall be accessible.
8. All doors and doorways on an accessible route shall comply with ADAAG. **EXCEPTION:** Doors and doorways where inmates are escorted by correctional officers at all times shall be exempt.
9. At least one toilet and bathing facility shall comply with ADAAG 4.22 and 4.23.
10. Beds in accessible cells shall have at least 36 inches clear width

maneuvering space located along one side. If more than one bed is provided in a room or cell, the clear space provided at adjacent beds may overlap.

11. When drinking fountains and coolers are provided it is recommended that a "HI - LO" fountain is used. this will permit wheelchair access and allow those who have difficulty bending a higher fountain.
12. Fixed or built-in seating and tables, within cells, or serving accessible cells (such as in the dayroom) shall comply with ADAAG 4.1.3(18).
13. Fixed benches shall be a minimum of 2 feet wide, 4 feet long and mounted 17 -19 inches above the finished floor.
14. At least one of each type of fixed or built-in storage facility (cabinets, shelves, closets, drawers) shall comply with ADAAG 4.25. Additional storage may be provided outside the dimensions required of ADAAG.
15. All controls intended for operation by inmates shall comply with ADAAG 4.27 regarding reaches and heights.
16. Auxiliary visual alarms (ADAAG 4.28.4) shall be provided in cells or rooms which are served by audible emergency warning systems and which house inmates who are allowed independent means of egress.
17. Permanently installed telephones shall have volume controls complying with ADAAG 4.31.5.
18. Cells or rooms with hearing impaired inmates shall have areas made adaptable for using portable visual alarms and communication devices made available by the operator of the facility. This shall include installation of electrical outlets (including outlets connected to facilities, control fire alarm systems) and telephone wiring in the cell or room.

While the following requirements are the only specific issues mentioned for correctional facilities, the implications for full compliance with ADAAG is made by the lack of any additional exemptions. This suggests that all other areas, especially common use areas and paths of travel, will meet the full requirements of ADAAG. The proposed Title II rules for correctional facilities defined common use areas to include: exercise areas, recreation areas, workshop and VoTech training areas, education and classrooms, counseling centers, cafeterias, commissaries, and medical facilities. Dayrooms serving accessible housing cells or rooms need to be accessible.

Where structural changes to existing facilities are the only way to achieve program accessibility, a **transition plan** (for entities with more than 50 employees) outlining steps necessary to complete the changes is required. The transition plan was to be completed by July 26, 1992 ( six months before the self-evaluation survey deadline! ), and must

include plans to:

- inventory the programs and activities conducted by the agency or entity.
- inventory the facilities in which agencies, programs or activities are conducted.
- evaluate the facilities for compliance with the ADA, Architectural Barriers Act of 1968, and Section 504 if applicable, and correct any problems identified.
- analyze how the programs or activities are conducted in the facilities.
- determine if there are physical barriers to program participation in the facilities.
- develop solutions to the problems and schedule for implementation.
- provide interested groups, especially organizations representing persons with disabilities, with the opportunity to review and comment on draft transition plan.
- identify the official responsible for implementation.

The entity should survey all facilities or portions of facilities, structures, equipment, roads, walks, parking lots, or other real or personal property, or interest in such property that is owned, operated, or leased and used for programs, activities, and services of that organization. The survey should list for each facility, or portion of, any inaccessible features that limit program accessibility. The entity should:

- List the steps that are planned to ensure existing facilities are program accessible, or if an alternative means of delivery is proposed.
- Document that new construction and renovation work will architecturally comply with the ADA Accessibility Guidelines.
- Document what non-structural measures will be taken to ensure program accessibility for existing facilities, such as relocating the activity to an accessible space, being able to relocate upon notice given by a qualified disabled person, revising the structure or format of the activity so the space is not needed, modifying equipment or redesigning equipment, or alternative delivery of services.
- Document steps that undertaken to ensure periodic communications with disabled program participants concerning accessible and inaccessible facilities.

The facility survey should be organized in a notebook, with tabular breakouts of the different architectural areas and how they correspond to the sections of ADAAG. The facility survey should have a checklist for each of the items of ADAAG and allow a respondent to check off an item for compliance or non-compliance, and allow for comments. It is very helpful if the survey team has a floor plan of the facility, usually reduced to an 11 inch by 14 inch format, and to take photographs of non-compliant elements. As non-complaint elements are identified they can be keyed to the floor plan and corresponding photographs.

The facility survey becomes the written record of the good faith effort made by the government agency in program accessibility. This is critical in preventing and defending against litigation regarding ADA issues. The survey establishes what the existing conditions were and identifies what areas need correction. If physical improvements are

made without the benefit of a survey's records, there is no way to show how and where improvements were made. The survey also serves as the data base to determine the budget for program and building alterations. A survey, done properly, is not a "quick and dirty" short process. The survey is a carefully detailed document that provides important facts and history of conditions and programs important to the public agency in the event of future litigation.

#### AUTHOR BIO

Randall I. Atlas Ph.D., AIA, CPP, of Atlas Safety & Security Design Inc., is a registered architect, a doctorate of criminology, and a Certified Protection Professional. Atlas has been a technical assistance consultant for the National Institute of Corrections since 1983, an adjunct professor of criminal justice at Florida International University, and recently conducted the required ADA Compliance Assessment Surveys at several Florida and Hawaii Correctional Institutions. Atlas serves on the ACA Design and Technology Committee and the American Institute of Architects Architecture for Justice Committee. He has conducted workshops on ADA at recent American Jail Association and American Correctional Association conferences, and the NIC Large Jail Network, and appointed to a national advisory board on ADA for the National Institute of Justice. Atlas has been a leading national resource on accessibility, barrier free design, premises liability, suicide prevention, and architectural security design. For more information please contact Dr. Atlas, ATLAS SAFETY & SECURITY DESIGN INC, at One Palm Bay Court, Miami, Florida 33138-5751. (800) 749-6029.