

71098

*Technology Assessment Program*

**NIJ Standard  
for  
Metallic Window Foil  
for Intrusion Alarm Systems**

*A Voluntary National Standard Promulgated by the  
National Institute of Justice.*

**AUGUST 1980**

**U.S. DEPARTMENT OF JUSTICE  
National Institute of Justice**

**NIJ STANDARD  
FOR  
METALLIC WINDOW FOIL FOR  
INTRUSION ALARM SYSTEMS**

**CONTENTS**

	Page
Foreword .....	v
1. Purpose and Scope.....	1
2. Classification.....	1
3. Definitions.....	1
4. Requirements.....	1
4.1 Electrical Resistance .....	1
4.2 Foil Breakage .....	1
5. Test Methods .....	1
5.1 Test Sample.....	1
5.2 Test Equipment .....	1
5.3 Electrical Resistance Test.....	3
5.4 Foil Breakage Test.....	3

## FOREWORD

Following a Congressional mandate\* to develop new and improved techniques, systems, and equipment to strengthen law enforcement and criminal justice, the National Institute of Law Enforcement and Criminal Justice, now the National Institute of Justice (NIJ), established the Law Enforcement Standards Laboratory (LESL) at the National Bureau of Standards. LESL's function is to conduct research that will assist law enforcement and criminal justice agencies in the selection and procurement of quality equipment.

In response to priorities established by NIJ, LESL is: (1) Subjecting existing equipment to laboratory testing and evaluation and (2) conducting research leading to the development of several series of documents, including national voluntary equipment standards, user guides, and technical reports.

This document, NIJ-STD-0319.00, Metallic Window Foil for Intrusion Alarm Systems, is a law enforcement equipment standard developed by LESL and approved and issued by NIJ. Additional standards as well as other documents are being issued under the LESL program in the areas of protective equipment, communications equipment, security systems, weapons, emergency equipment, investigative aids, vehicles and clothing.

This equipment standard is a technical document consisting of performance and other requirements together with a description of test methods. Equipment which can meet these requirements is of superior quality and is suited to the needs of law enforcement agencies. Purchasers can use the test methods described in this standard to determine firsthand whether a particular equipment item meets the requirements of the standard, or they may have the tests conducted on their behalf by a qualified testing laboratory. Law enforcement personnel may also reference this standard in purchase documents and require that any equipment offered for purchase meet its requirements and that this compliance be either guaranteed by the vendor or attested to by an independent testing laboratory.

The necessarily technical nature of this NIJ standard, and its special focus as a procurement aid, make it of limited use to those who seek general guidance concerning metallic window foil for intrusion alarm systems. The User Guide Series is designed to fill that need. We plan to issue guides to various items of law enforcement equipment as soon as possible, within the constraints of available funding and the overall NIJ program.

The user guides being issued are highly readable and tutorial in nature in contrast to the standards, which are highly technical and intended for laboratory use by technical personnel. The guides provide, in non-technical language, information for purchasing agents and other interested persons concerning the capabilities of equipment currently available. They may then select equipment appropriate to the performance required by their agency.

NIJ standards are subjected to continuing review.\*\* Technical comments and recommended revisions are invited from all interested parties. Suggestions should be addressed to the Program Manager for Standards, National Institute of Justice, U.S. Department of Justice, Washington, DC 20531.

Lester D. Shubin  
Program Manager for Standards  
National Institute of Justice

\*Section 402(b) of the Omnibus Crime Control and Safe Streets Act of 1968, as amended.

\*\*Prior to citing this standard, or any other NIJ equipment standard, in a contract document the user should verify that the most recent edition is used. Write to: Chief, Law Enforcement Standards Laboratory, National Bureau of Standards, Washington, DC 20234.

# NIJ STANDARD FOR METALLIC WINDOW FOIL FOR INTRUSION ALARM SYSTEMS

## 1. PURPOSE AND SCOPE

The purpose of this standard is to establish performance requirements and methods of test for metallic window foil used in intrusion alarm systems as a sensor to detect the breakage of glass. This standard applies only to metallic foil for use on glazing materials consisting solely of glass.

## 2. CLASSIFICATION

Metallic window foils covered by this standard are classified into two types.

### 2.1 Type I

Metallic window foil that is pre-coated with adhesive.

### 2.2 Type II

Metallic window foil that is not pre-coated with adhesive.

## 3. DEFINITIONS

None

## 4. REQUIREMENTS

### 4.1 Electrical Resistance

When tested in accordance with paragraph 5.3, the resistance of a 10-meter (33-foot) length of metallic window foil shall not exceed 12.5 ohms.

### 4.2 Foil Breakage

When metallic window foil is tested in accordance with paragraph 5.4, a minimum of 17 of 20 test specimens shall exhibit an open circuit resistance equal to or greater than 100 k $\Omega$  after the test panels have been broken.

## 5. TEST METHODS

### 5.1 Test Sample

The test sample shall consist of at least 15 m (50 ft) of metallic window foil.

### 5.2 Test Equipment

#### 5.2.1 Glass Panels

The glass test panels shall consist of glass 30 by 35 cm (12 by 14 in). The thickness of each panel shall be

between 0.520 and 0.545 cm (0.205 and 0.215 in) as determined by measurements near the edge of the panel at the approximate midpoint of each of the four sides.

### 5.2.2 Glass Cutter

The glass cutter shall make a cut mark that shows no chipping of the glass surface.

### 5.2.3 Break Fixture

The break fixture, shown in figure 1, shall consist of two flat platforms, each approximately 20 by 40 cm (8 by 16 in), mounted on a common base approximately 40 by 40 cm (16 by 16 in) square. One platform shall be  $1.25 \pm 0.05$  cm ( $0.5 \pm 0.02$  in) higher than the other. The inside end of the higher platform shall be made of metal, such as aluminum or steel. The top edge of the metal end, which shall be square and not rounded, forms the break edge of the fixture. The remaining parts of the fixture can be made of any convenient material such as wood, metal, plastic, etc. The surfaces of the two levels of the break fixture shall be sufficiently parallel that a straight edge placed anywhere on the upper surface, perpendicular to and extending beyond the break edge, as shown in figure 1, shall be  $1.25 \pm 0.05$  cm ( $0.50 \pm 0.02$  in) above the lower surface at a distance of 15 cm (6 in) from the break edge.

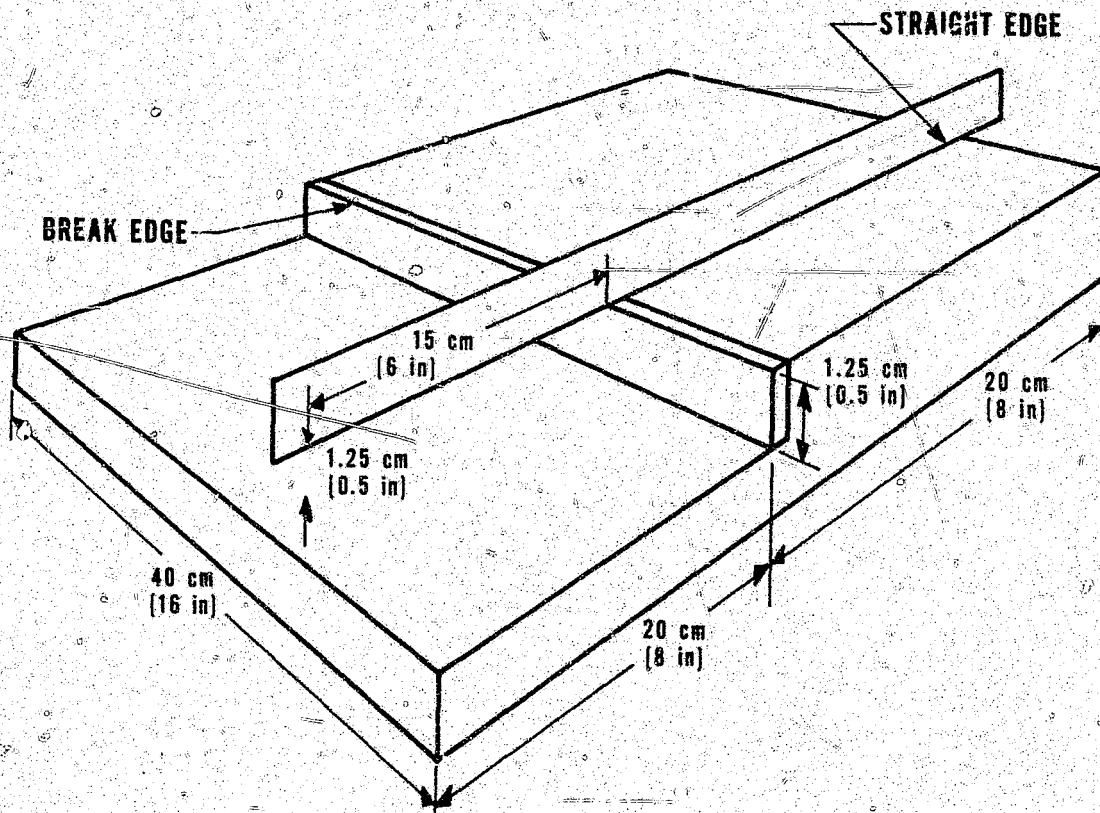

FIGURE 1. Break fixture.

### 5.2.4 Ohmmeter

The ohmmeter or ohmmeters shall measure resistances between 10 and 15  $\Omega$  and between 100 k $\Omega$  and 1.0 M $\Omega$  with a maximum uncertainty of  $\pm 6$  percent.

### 5.2.5 Adhesive

The varnish or other adhesive used to adhere type II metallic window foil to the test panels shall comply with the specifications of the foil manufacturer.

### 5.3 Electrical Resistance Test

Use the ohmmeter to measure the resistance of a 10-m (33-ft) length of metallic foil. In making this test, be sure that the test probes of the ohmmeter are in good electrical contact with the metallic foil and that adhesive or any protective coatings do not interfere with the measurement.

### 5.4 Foil Breakage Test

#### 5.4.1 Sample Preparation

Use the glass cutter to scribe a cut line across the 30-cm (12-in) width of each glass test panel to be used. Normally, eight panels should be prepared for each sample of metallic foil that is to be evaluated. The scribe line should be distinct, continuous, and show no evidence of chipping of the glass surface. The scribe line should be parallel to and  $15.0 \pm 0.2$  cm ( $6.0 \pm 0.1$  in) from one end of the glass test panel, as shown in figure 2.

Thoroughly clean both sides of each scribed glass panel with a mild soap solution and completely rinse it with clean water. Then clean each panel with methanol applied with a lint-free cloth and dry it with another lint-free cloth. Use caution throughout the cleaning process to prevent oil from fingers or other sources from getting onto the glass.

Apply a 30-cm (12-in) length of 2-cm ( $3/4$ -in) wide cellulose acetate pressure-sensitive adhesive tape to the bottom of each glass test panel directly beneath and centered on the scribe line as shown in figure 2. The tape will keep the two parts of the test panel from moving after the glass has been broken.

Follow the manufacturer's instructions and apply five strips of metallic foil on 5-cm (2-in) centers perpendicular to the scribe line and on the same side of the glass test panel. Apply metallic foil to the remaining test panels in the same manner. Store the test panels in the laboratory for the period of drying time recommended by the manufacturer before proceeding with the test. In the absence of a manufacturer-specified drying time, dry it for at least five days.

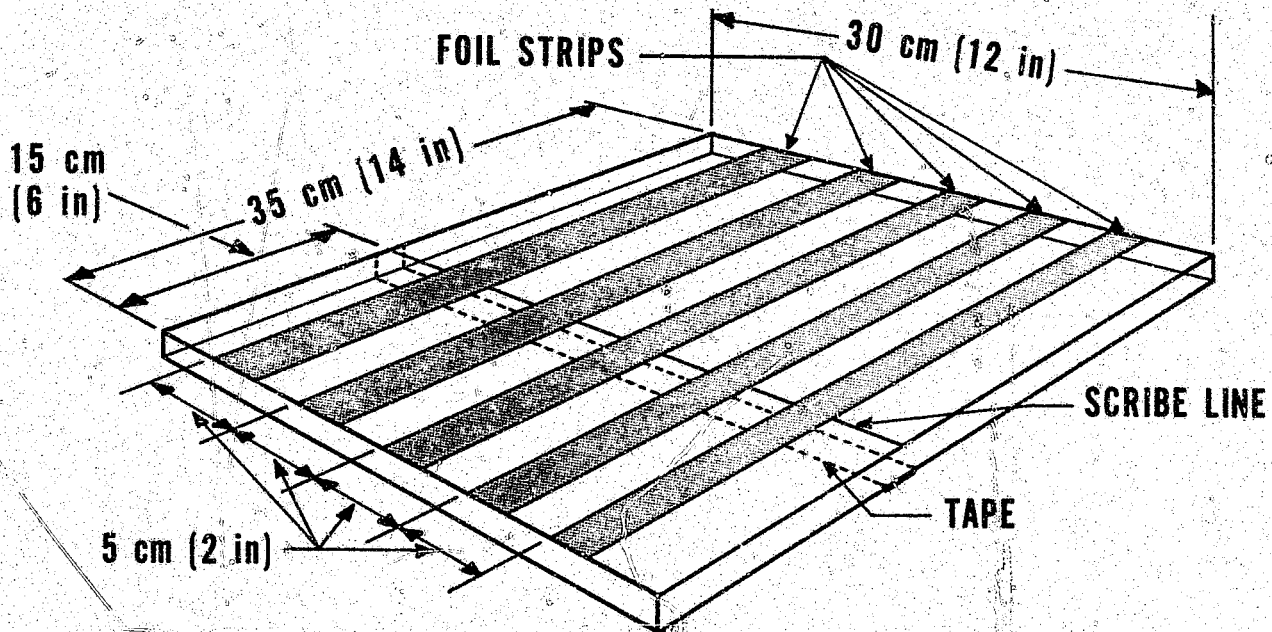

FIGURE 2. Position of tape and foil strips on glass panel.

#### 5.4.2 Breaking Procedure

Breaking plate glass can be dangerous, so proper eye and hand protection should be worn during the breaking operation. Place one of the prepared test panels on the top level of the break fixture, foil side up, with the 15-cm (6-in) side of the test panel extending out from the break edge, as shown in figure 3. Position the test panel so that the scribe line is directly above and aligned with the break edge. Hold the supported portion of the glass panel against the top platform with one hand, such as at area A of figure 4, and press firmly and quickly on the other end of the

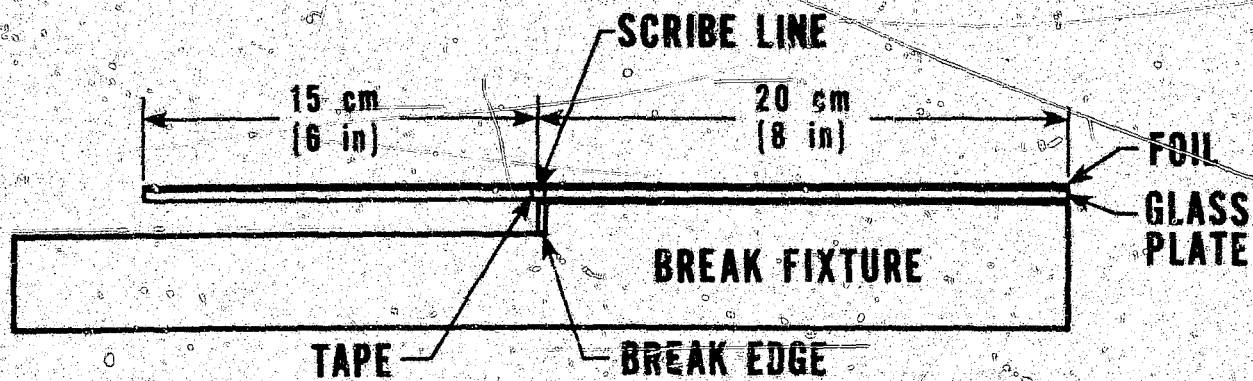

FIGURE 3. Position of glass plate on break fixture.

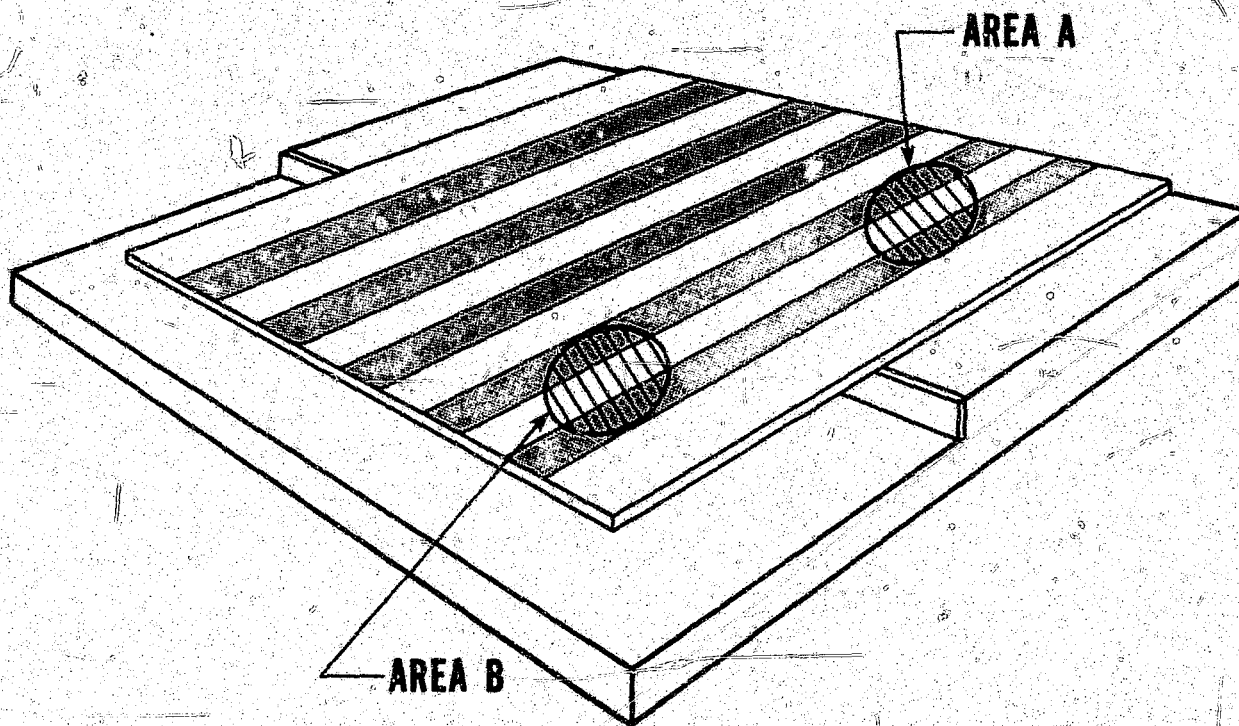

FIGURE 4. Position of hands during breaking of glass.

glass panel with the other hand, placed as at area B of figure 4. This action should result in a clean break along the scribe line. Remove your hands from the test panel carefully so that the two parts of the glass panel do not move further.

Check that the two parts are in the proper position; i.e., with no hand pressure on the glass panel, the fully supported part should rest flat on the upper platform and the other part should be supported by the tape at the break edge of the fixture and along the opposite edge by the lower platform of the fixture.



### 5.4.3 Evaluation Procedure

Examine the glass test panel to be sure there is a good clean break across at least a portion of the panel. There should be only a single break line and it should follow the original scribe line. Only those foil strips that cross a good clean break should be tested electrically. Thus, fewer than five foil strips may be evaluated for each test panel that is broken.

Use an ohmmeter meeting the requirements of paragraph 5.2.4 to measure the electrical resistance of each foil strip across the break, making contact with the test probes at points within 1 cm (0.5 in) of each end of the test strip.

Continue to evaluate individual foil strips until at least 20 have been tested. If all of the foil strips on each glass test panel cross a clean break, a total of four glass test panels should be broken and the resistance of each strip measured. If some strips do not cross a clean break, break additional panels until the electrical resistances of 20 strips have been measured.

**U.S. DEPARTMENT OF JUSTICE  
National Institute of Justice**

**Harry M. Brill, Acting Director**

**ACKNOWLEDGMENTS**

This standard was formulated by the Law Enforcement Standards Laboratory of the National Bureau of Standards under the direction of Jacob J. Diamond and Lawrence K. Eliason, successive Chiefs of LESL. Technical research was performed by Gerard N. Stenbakken of the NBS Electrosystems Division.

**END**