



U.S. Department of Justice
National Institute of Justice.

Technology Assessment Program

NIJ Standard-0219.00

Continuous Signal-Controlled Selective Signaling

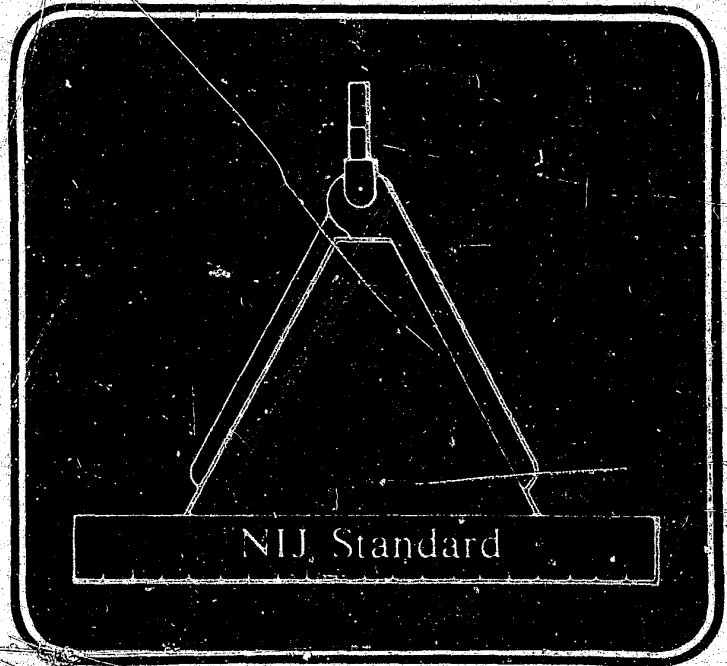

A Program of the National Institute of Justice

71097

Technology Assessment Program

**NIJ Standard
for**

**Continuous Signal-Controlled
Selective Signaling**

*A Voluntary National Standard Promulgated by the
National Institute of Justice.*

AUGUST 1980

**U.S. DEPARTMENT OF JUSTICE
National Institute of Justice**

**U.S. DEPARTMENT OF JUSTICE
National Institute of Justice**

Harry M. Bratt, Acting Director

ACKNOWLEDGMENTS

This standard was formulated by the Law Enforcement Standards Laboratory of the National Bureau of Standards under the direction of Jacob J. Diamond and Lawrence K. Eliason, successive Chiefs of LESL, and Marshall J. Treado, Manager, Communication Systems Program. James Blair of the Institute for Telecommunications Sciences, Boulder, Colorado, was responsible for the preparation of the standard.

NIJ STANDARD FOR CONTINUOUS SIGNAL-CONTROLLED SELECTIVE SIGNALING

CONTENTS

	Page
Foreword	v
1. Purpose and Scope.....	1
2. Classification.....	1
3. Definitions.....	1
4. Requirements.....	4
4.1 Minimum Performance.....	4
4.2 User Information	4
4.3 Test Sequence.....	4
4.4 Environmental Characteristics.....	4
4.5 Modulation Code Frequencies	6
4.6 Radio Receiver/Decoder Characteristics	6
4.7 Radio Transmitter/Encoder Characteristics.....	7
5. Test Methods.....	7
5.1 Standard Test Conditions	7
5.2 Test Equipment	9
5.3 Environmental Tests	11
5.4 Radio Receiver/Decoder Tests.....	11
5.5 Radio Transmitter/Encoder Tests	17
Bibliography	20

FOREWORD

Following a Congressional mandate* to develop new and improved techniques, systems, and equipment to strengthen law enforcement and criminal justice, the National Institute of Law Enforcement and Criminal Justice, now the National Institute of Justice (NIJ), established the Law Enforcement Standards Laboratory at the National Bureau of Standards. LESL's function is to conduct research that will assist law enforcement and criminal justice agencies in the selection and procurement of quality equipment.

In response to priorities established by NIJ, LESL is: (1) Subjecting existing equipment to laboratory testing and evaluation and (2) conducting research leading to the development of several series of documents, including national voluntary equipment standards, user guides, and technical reports.

This document, NIJ-STD-0219.00, Continuous Signal-Controlled Selective Signaling, is a law enforcement equipment standard developed by LESL and approved and issued by NIJ. Additional standards as well as other documents are being issued under the LESL program in the areas of protective equipment, communications equipment, security systems, weapons, emergency equipment, investigative aids, vehicles and clothing.

This equipment standard is a technical document consisting of performance and other requirements together with a description of test methods. Equipment which can meet these requirements is of superior quality and is suited to the needs of law enforcement agencies. Purchasers can use the test methods described in this standard to determine firsthand whether a particular equipment item meets the requirements of the standard, or they may have the tests conducted on their behalf by a qualified testing laboratory. Law enforcement personnel may also reference this standard in purchase documents and require that any equipment offered for purchase meet its requirements and that this compliance be either guaranteed by the vendor or attested to by an independent testing laboratory.

The necessarily technical nature of this NIJ standard and its special focus as a procurement aid make it of limited use to those who seek general guidance concerning continuous signal-controlled selective signaling. The User Guide Series is designed to fill that need. We plan to issue guides to various items of law enforcement equipment as soon as possible, within the constraints of available funding and the overall NIJ program.

The user guides being issued are highly readable and tutorial in nature in contrast to the standards, which are highly technical and intended for laboratory use by technical personnel. The guides provide, in non-technical language, information for purchasing agents and other interested persons concerning the capabilities of equipment currently available. They may then select equipment appropriate to the performance required by their agency.

NIJ standards are subjected to continuing review.** Technical comments and recommended revisions are invited from all interested parties. Suggestions should be addressed to the Program Manager for Standards, National Institute of Justice, U.S. Department of Justice, Washington, DC 20531.

Lester D. Shubin
Program Manager for Standards
National Institute of Justice

*Section 402(b) of the Omnibus Crime Control and Safe Streets Act of 1968, as amended.

**Prior to citing this standard, or any other NIJ equipment standard, in a contract document the user should verify that the most recent edition is used. Write to: Chief, Law Enforcement Standards Laboratory, National Bureau of Standards, Washington, DC 20234.

NIJ STANDARD FOR CONTINUOUS SIGNAL-CONTROLLED SELECTIVE SIGNALING

1. PURPOSE AND SCOPE

The purpose of this document is to establish performance requirements and methods of test for continuous signal-controlled selective signaling in transceivers used by law enforcement agencies. Performance standards for such transceivers, exclusive of special subsystems such as signal-controlled selective signaling and voice privacy, have already been published [7-11].*

This standard applies to continuous tone-controlled selective signaling (CTCSS) with tone frequencies below 300 Hz and to continuous digital-controlled selective signaling (CDCSS) with data rates between 100 and 150 bits per second.

2. CLASSIFICATION

For the purposes of this standard, continuous signal-controlled selective signaling systems are classified by their coding methods.

2.1 Type I

Continuous tone-controlled selective signaling (CTCSS).

2.2 Type II

Continuous digital-controlled selective signaling (CDCSS).

3. DEFINITIONS

The principal terms used in this document are defined in this section. Additional definitions relating to law enforcement communications are given in LESP-RPT-0203.00 [5].

3.1 Bias Distortion

For a binary-coded signal, bias distortion is the lengthening of either the mark or space elements. When the space elements are lengthened, the distortion is called spacing bias; when the mark elements are lengthened, it is called marking bias.

3.2 Code Data Rate

The number of bits per second of the CDCSS code.

3.3 Code Modulation Deviation

The permissible range of FM carrier modulation deviation resulting from the amplitude of the modulation code.

3.4 Continuous Digital-Controlled Selective Signaling (CDCSS)

A system wherein the radio receivers are equipped with digital decoders that allow audio signals to appear at the receiver audio outputs only while a carrier modulated with a specific binary-coded signal is being received.

*Numbers in brackets refer to the references on page 20.

3.5 Continuous Tone-Controlled Selective Signaling (CTCSS)

A system wherein the radio receivers are equipped with tone-responsive devices that allow audio signals to appear at the receiver audio outputs only while a carrier modulated with a tone of specific frequency is being received.

3.6 CDCSS Modulation Code

The sequence of binary digits, assigned to particular CDCSS receivers, that is used to encode the transmitter and decode the receivers.

3.7 CTCSS Modulation Code

The frequency, assigned to particular CTCSS receivers, that is used to encode the transmitter and decode the receivers.

3.8 Decoder

The device in the receiver that furnishes an output for squelch opening when, and only when, the proper CTCSS or CDCSS modulation code is being received.

3.9 Decoder Tolerance to Bias Distortion

The maximum mark or space bias distortion, in percent, that a CDCSS decoder can tolerate and still decode properly.

3.10 Decoder Response Bandpass

The range of CTCSS frequencies that will result in proper decoder operation when the input signal is applied to the receiver.

3.11 Digital Distortion

The distortion in a binary-coded signal caused by displacement of a mark-to-space or space-to-mark transition from its normal position. The value of the distortion is the displacement expressed as a percentage of the bit length.

3.12 Encoder

A transmitter component that generates a CTCSS or CDCSS modulation code and supplies it to the modulator.

3.13 Encoder Clock Stability

The ability of the encoder clock frequency to remain stable as other conditions, such as the supply voltage, vary.

3.14 Encoder Clock Jitter

The amount of phase jitter on the clock signal.

3.15 Encoder Response Time

The elapsed time from the moment the push-to-talk control circuit is activated at the transmitter until the amplitude of the CTCSS modulation code at the input to the associated transmitter modulator has reached 90 percent of maximum voltage or the number 1 bit in the CDCSS modulation code appears at the modulator input.

3.16 Equipment Coding Capability

The number of discrete CDCSS codes which can be selected using the operator's controls.

3.17 Phase Jitter

Abrupt, spurious variations in the phase of successive pulses, referenced to the phase of a continuous oscillator.

3.18 Pre-Transmission Monitoring Capability

The capability of disabling the signal-controlled squelch at the receiver so that the carrier frequency can be monitored before transmitting, to prevent interference with other transmissions.

3.19 Receiver Hum and Noise

The decrease in audio output level, in decibels, of a CTCSS or CDCSS receiver when standard test modulation is removed but the appropriate modulation code is present.

3.20 Receiver Response Time

The elapsed time between the application of CTCSS or CDCSS modulation code to the receiver rf input signal which is modulated by standard test modulation, and the time that the audio voltage at the receiver input increases to 90 percent of its maximum value.

3.21 SINAD (CDCSS) Ratio

The ratio of the components of the audio output of a CDCSS receiver, expressed in decibels, equal to (1) signal plus noise plus distortion plus binary code, divided by (2) noise plus distortion plus binary code.

3.22 SINAD (CTCSS) Ratio

The ratio of the components of the audio output of a CTCSS receiver, expressed in decibels, equal to (1) signal plus noise plus distortion plus tone code, divided by (2) noise plus distortion plus tone code.

3.23 Squelch

A circuit function for preventing a radio receiver from producing audiofrequency output power in the absence of proper rf input signals.

3.24 Squelch Opening SINAD Ratio

That SINAD ratio obtained at the receiver output at an input level just adequate to open, and keep open, the squelch circuit of a receiver when an rf input signal, modulated with a standard test modulation and CTCSS or CDCSS modulation code, is fed to the receiver input.

3.25 System Coding Capacity

The maximum number of usable discrete codes that can be provided by a given CDCSS system.

3.26 Threshold Squelch Position

The adjustment of the squelch control, starting from the maximum unsquelched position, that first reduces the audio noise output power by a specified amount.

3.27 Total Peak Digital Distortion

The maximum distortion measured in a period not less than one code length.

3.28 Transmitter Tone Distortion

The harmonic content in the CTCSS modulation code at the transmitter output expressed as a percentage of the total rms output modulation voltage.

3.29 Transmitter Total Distortion

A measure of distortion of the transmitter output waveform resulting from the combined effect of CTCSS modulation code and standard test modulation.

4. REQUIREMENTS

4.1 Minimum Performance

The minimum requirement for each CTCSS or CDCSS characteristic shall be the value given below and/or listed in table 1. These performance requirements meet or exceed those given in the Rules and Regulations published by the Federal Communications Commission. In addition to the requirements listed, all of the licensing and operating requirements of the FCC Rules and Regulations shall apply.

4.2 User Information

The following information shall be supplied to the user by the manufacturer or distributor:

- (a) The assigned CTCSS modulation codes, the power source current in the operating mode and a nominal value for each CTCSS characteristic listed in table 1.
- (b) The assigned CDCSS modulation codes, the equipment coding capacity, the system coding capacity, the power source current in the operating mode and a nominal value for each CDCSS characteristic listed in table 1.
- (c) The operating frequencies and the range of temperatures within which the equipment is designed to be operated.

4.3 Test Sequence

The test sequence shall be in the order listed herein. The receiver/decoder and transmitter/encoder combinations shall be tested separately. Each combination shall first be subjected to the environmental tests, and then shall be tested for conformance with paragraph 4.5 through 4.7.

4.4 Environmental Characteristics

The ability of the CTCSS or the CDCSS to operate in environmental extremes shall be determined using the test methods described in paragraph 5.3.

4.4.1 Temperature Stability

Low temperature tests shall be conducted at -30°C (-22°F) or the lowest temperature at which the manufacturer states (par. 4.2.c) that his unit will operate properly, whichever is lower, and high temperature tests shall be conducted at 60°C (140°F) or the highest temperature at which the manufacturer states that his unit will operate properly, whichever is higher.

When the equipment is operated at low and high temperatures, as defined above, its performance shall not be degraded to more than (items N through W) for the characteristics listed.

4.4.2 Humidity Stability

After the CTCSS or CDCSS system units have been maintained at 50°C (122°F) and 90 percent relative humidity or greater for at least 8 hours, their performance shall not be degraded to more than (items X through AG) for the characteristics listed.

4.4.3 Vibration Stability

No fixed part of the encoder or decoder shall come loose, nor any adjustable part be shifted in position or adjustment as a result of this test. This test is not applicable to equipment used at fixed sites.

4.4.4 Shock Stability

No fixed part of the encoder or decoder shall come loose, nor any adjustable part be shifted in position or adjustment as a result of this test. This test is not applicable to equipment used at fixed sites.

TABLE 1. Minimum performance requirements for continuous signal-controlled selective signaling

Characteristic	Requirement	
	CTCSS	DCSS
<u>Radio Receiver/Decoder Characteristics</u>		
A. Receiver Response Time:		<300 ms
above 100 Hz	<250 ms	
below 100 Hz	100 Hz × 250 ms	
	← CTCSS Code Frequency	
B. Squelch Opening SINAD Ratio	<8 dB	<10 dB
C. Decoder Response Bandpass	Between ±0.5% and ±3.0% of Code Frequency	NA*
D. Receiver Hum and Noise	30 dB	35 dB
E. Decoder Tolerance to Bias Distortion	NA	>45%
<u>Radio Transmitter/Encoder Characteristics</u>		
F. Code Frequency Tolerance	±0.5%	NA
G. Code Frequency Stability (Supply voltage varied ±20%)	±0.5%	NA
H. Code Modulation Deviation	±0.5 to ±1.0 kHz	±0.5 to ±1.0 kHz
I. Encoder Response Time	<50 ms	<50 ms
J. Transmitter Tone Distortion	<5%	NA
K. Transmitter Total Distortion	<15%	NA
L. Encoder Clock Stability	NA	±0.001%
M. Encoder Clock Jitter	NA	<10 μs
<u>Temperature Characteristics</u>		
N. Receiver Response Time	<400 ms	<400 ms
O. Squelch Opening SINAD Ratio	<11 dB	<12 dB
P. Decoder Response Bandpass	Between ±0.5% and ±3.0% of Code Frequency	NA
Q. Receiver Hum and Noise Level	25 dB	25 dB
R. Code Frequency Tolerance	±0.5%	NA
S. Code Modulation Deviation	±0.5 to ±1.0 kHz	±0.5 to ±1.0 kHz
T. Encoder Response Time	<100 ms	<100 ms
U. Transmitter Tone Distortion	<10%	NA
V. Transmitter Total Distortion	<20%	NA
W. Encoder Clock Stability	NA	±0.03%
<u>Humidity Characteristics</u>		
X. Receiver Response Time	<400 ms	<400 ms
Y. Squelch Opening SINAD Ratio	<11 dB	<12 dB
Z. Decoder Response Bandpass	Between ±0.5% and ±3.0% of Code Frequency	NA
AA. Receiver Hum and Noise Level	25 dB	25 dB
AB. Code Frequency Tolerance	±0.5%	NA
AC. Code Modulation Deviation	±0.5 to ±1.0 kHz	±0.5 to ±1.0 kHz
AD. Encoder Response Time	<100 ms	<100 ms
AE. Transmitter Tone Distortion	<10%	NA
AF. Transmitter Total Distortion	<20%	NA
AG. Encoder Clock Stability	NA	±0.03%

*NA=Not Applicable.

4.5 Modulation Code Frequencies

The CTCSS modulation code frequencies assigned in a given area should all be from a single one of the three groups listed in table 2, where possible.

TABLE 2. CTCSS modulation code frequencies available for assignment

Group A	(Hz)	Group B	(Hz)	Group C	(Hz)
67.0	151.4	71.9	146.2	74.4	
77.0	162.2	82.5	156.7	79.7	
88.5	173.8	94.8	167.9	85.4	
100.0	186.2	103.5	179.9	91.5	
107.2	203.5	110.9	192.8		
114.8	218.1	118.8	210.7		
123.0	233.6	127.3	225.7		
131.8	250.3	136.5	241.8		
141.3					

The assignments in a given area should be made from a single one of the groups where possible.

4.6 Radio Receiver/Decoder Characteristics

The characteristics of pre-transmission monitoring capability, receiver response time, squelch opening SINAD ratio, decoder response bandpass, receiver hum and noise, and decoder tolerance to bias distortion shall be measured in accordance with paragraph 5.4.

4.6.1 Pre-Transmission Monitoring Capability

The receiver/decoder shall have a decoder-disable switch by means of which pre-transmission monitoring can be accomplished.

4.6.2 Receiver Response Time

The receiver response time shall not exceed (item A) with a 1 mV receiver input.

4.6.3 Squelch Opening SINAD Ratio

The squelch opening SINAD ratio shall not exceed (item B) with a 1 mV receiver input.

4.6.4 Decoder Response Bandpass

The CTCSS decoder response bandpass shall be not less than ± 0.5 percent nor more than ± 3.0 percent of the code frequency (item C).

4.6.5 Receiver Hum and Noise

The receiver hum and noise level shall be at least (item D) below the nominal receiver audio output level.

4.6.6 Decoder Tolerance to Bias Distortion

CTCSS decoder tolerance to bias distortion shall not be less than 45 percent (item E).

4.7 Radio Transmitter/Encoder Characteristics

The characteristics of modulation code tolerance and stability, code modulation deviation, encoder response time, transmitter tone distortion, transmitter total distortion, encoder clock stability and encoder clock jitter shall be measured in accordance with paragraph 5.5.

4.7.1 Modulation Code Tolerance and Stability

The CTCSS code frequency shall be within ± 0.5 percent (item F) of the assigned value at all times during the standard duty cycle except for the initial two seconds after applying power to the encoder. When the standard encoder supply voltage is varied plus and minus 20 percent, the CTCSS code frequency shall be within ± 0.5 percent (item G) of its assigned value.

4.7.2 Code Modulation Deviation

The code modulation deviation shall be between ± 0.5 and ± 1.0 kHz (item H).

4.7.3 Encoder Response Time

The encoder response time shall not be greater than 50 milliseconds (item I).

4.7.4 Transmitter Tone Distortion

The CTCSS transmitter tone distortion shall not be greater than 5 percent (item J).

4.7.5 Transmitter Total Distortion

The CTCSS transmitter total distortion shall not be greater than 15 percent (item K).

4.7.6 Encoder Clock Stability

The CDCSS encoder clock frequencies at power supply voltages 20 percent above and 20 percent below the standard power supply voltage shall be within ± 0.001 percent (item L) of the frequency at standard supply voltage.

4.7.7 Encoder Clock Jitter

The CDCSS encoder clock jitter shall not exceed 10 microseconds (item M).

5. TEST METHODS

5.1 Standard Test Conditions

Allow all measurement equipment to warm up until the system has achieved sufficient stability to perform the measurement. Unless otherwise specified, perform all measurements under standard test conditions. With the exception of the CTCSS or CDCSS, disable or bypass all special subsystems, such as voice privacy, before testing.

5.1.1 Standard Temperature

Standard ambient temperature shall be between 20 °C (68 °F) and 30 °C (86 °F).

5.1.2 Standard Relative Humidity

Standard ambient relative humidity shall be between 10 and 85 percent.

5.1.3 Standard Power Supply Voltage

For nominal 12-volt dc mobile equipment, the standard supply voltage shall be determined by the equation $V = 13.8 - 0.02 I$, where I is the current (in amperes) drawn by the unit under test. For example, if the current while receiving is 5 amperes, the standard supply voltage is 13.7 volts. A well-filtered electronic power supply should be used in place of a battery for safety and convenience. The standard supply voltage shall be applied to the input terminals of the dc supply cables (including all connectors and circuit protectors) furnished by the manufacturer and adjusted to within 1 percent of the value calculated above.

For personal/portable equipment, the standard supply voltage shall be that stated by the manufacturer and shall be applied to the receiver power supply input terminals. It may be supplied by a battery of the same type as that normally used in the equipment or, preferably, by a well-filtered electronic dc supply that is adjusted to a voltage that is within 1 percent of the voltage required.

For fixed and base station equipment, the standard supply voltage shall be 120 volts, 60 Hz, unless otherwise stated by the manufacturer. Voltage measurements should be made at the power supply input terminals, if practical, and adjusted to within 1 percent of the required value.

5.1.4 Standard Test Frequency

The standard test frequency shall be any one of the operating frequencies specified in accordance with paragraph 4.2.2.

5.1.5 Test Modulations

5.1.5.1 Standard Test Modulation

Standard test modulation shall be a 1 kHz sinusoidal modulating signal having less than 1 percent total distortion at the level required to produce a ± 3 kHz frequency deviation.

5.1.5.2 CDCSS Test Modulation

CDCSS test modulation shall be a binary code whose total peak digital distortion shall be less than 3 percent and whose amplitude shall be sufficient to produce a carrier frequency deviation in the range of ± 0.5 to ± 1.0 kHz.

5.1.5.3 CTCSS Test Modulation

CTCSS test modulation shall be a sinusoidal signal at one of the frequencies given in table 2, of sufficient amplitude to produce a carrier deviation in the range of ± 0.5 to ± 1.0 kHz and having less than 1 percent total distortion.

5.1.6 Standard Duty Cycle

5.1.6.1 Fixed and Base Station Equipment

The standard duty cycle shall be continuous operation in the transmit mode for fixed and base station transmitters and continuous operation in the receive mode for fixed and base station receivers.

5.1.6.2 Mobile Equipment

The standard duty cycle shall be 2 minutes in the transmit mode followed by 3 minutes in the standby mode for mobile transmitters and 2 minutes in the receive mode followed by 3 minutes in the standby mode for mobile receivers.

5.1.6.3 Personal/Portable Equipment

The standard duty cycle shall be 12 seconds in the transmit mode followed by 68 seconds in the standby mode for personal/portable transmitters and 60 seconds in the receive mode followed by 20 seconds in the standby mode for personal/portable receivers.

5.1.7 Standard Squelch Adjustment

The receiver squelch control shall be adjusted to the maximum unsquelch position for all measurements except where otherwise specified.

5.2 Test Equipment

This section is limited to the equipment which is the most critical in making the measurements discussed in this standard. All other test equipment shall be of comparable quality.

5.2.1 FM Signal Generator

The FM signal generator shall have a 50 ohm output impedance, a standing wave ratio of 1.2 or less, and an output level accurate to ± 2 dB. The generator shall be capable of internally generating the standard test modulation (par. 5.1.5.1) and have provisions for external modulation. The generator should include a digital frequency counter having an uncertainty no greater than one part in 10^6 , and a deviation monitor or calibrated control for determining the peak frequency deviation with an uncertainty no greater than 5 percent. If an integral frequency counter is not included, a separate frequency counter having the required accuracy shall be provided.

5.2.2 Code Generator

The code generator shall be capable of producing CDCSS test modulation (par. 5.1.5.2) when used to modulate the FM signal generator.

5.2.3 Frequency Counter

The frequency counter shall be capable of measuring period duration over a frequency range of 100 to 300 Hz with an accuracy of 1 part in 10^6 . Input sensitivity shall be 100 mV or better and the input impedance shall be at least 0.5 megohm.

5.2.4 Audio Generators

Audio generator 1 shall be capable of producing standard test modulation (par. 5.1.5.1) when used in the test circuits.

Audio generator 2 shall be capable of producing CTCSS test modulation (par. 5.1.5.3) when used in the test circuits.

5.2.5 Code Distorting Unit

The code distorting unit shall be capable of inducing from 5 to 50 percent of mark and space distortion on an input code that has less than 3 percent total peak distortion. The output impedance shall be 600 ohms maximum and the bias distortion of the output code shall be continuously variable. The unit may be part of the code generator (par. 5.2.2).

Figure 1 shows a logic diagram of a possible distorting unit. Here the delay of one of the variable one-shots is increased to produce mark bias and the delay of the other variable one-shot is increased for space bias. In either case, only one pair of the one-shots is increased in delay at a time, with the other set at minimum delay.

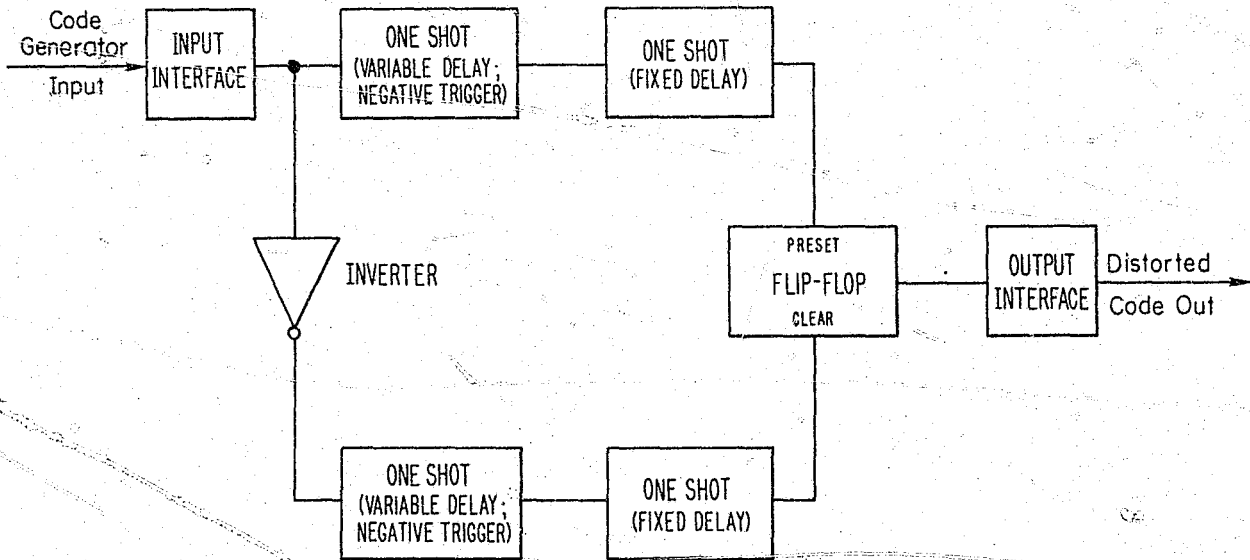

FIGURE 1. Logic diagram for code distorting unit.

5.2.6 Test Receiver

The test receiver used to determine transmitter CTCSS tone distortion and transmitter CTCSS total distortion shall include a standard audio output load (par. 5.2.6.6) as specified by the manufacturer of the test receiver and shall have the characteristics specified in the following paragraphs.

5.2.6.1 Audio Response

The audio response shall not vary more than one decibel from a 750 microsecond de-emphasis characteristic when the system deviation is held constant and the modulation is varied between 0.05 and 3 kHz.

5.2.6.2 Harmonic Distortion

The audiofrequency harmonic distortion shall be less than one percent at standard test modulation. The harmonic distortion at 1 kHz (for larger than rated system deviation) shall be less than 3 percent. The harmonic distortion shall be measured when the test receiver is tuned to a nominal 1 mV rf source which is modulated by a sine wave at a level which produces a system deviation 50 percent greater than rated system deviation (i.e., ± 7.5 kHz).

5.2.6.3 Audio Hum and Noise Ratio

The unswitched audio hum and noise level shall be at least 55 dB below the audio output power when measured with a 1 mV input signal.

5.2.6.4 Adjacent Channel Interference

The test receiver shall differentiate by 85 dB or more between a desired modulated signal and a modulated adjacent channel signal 30 kHz on either side, when the adjacent channel interference degrades the desired signal from 12 dB SINAD to 6 dB SINAD.

5.2.6.5 Selectivity

The test receiver shall have a bandwidth of 24 to 30 kHz at the -80 decibel points.

5.2.6.6 Standard Audio Output Load

The standard audio output load shall consist of a resistor whose resistance is equal to the load impedance into which the test receiver normally operates.

5.2.7 Adding Circuit

The purpose of the adding circuit is to combine a modulation input from one audio generator with a CTCSS modulation input from another audio generator or a CDCSS modulation from a code generator. The signal loss at each input shall not exceed 12 dB and shall be within ± 0.5 dB of the other. The input impedances shall match the output impedances of the audio generators and the output impedance shall be compatible with the FM signal generator external modulation input circuit.

5.2.8 Standard RF Output Load

The standard rf transmitter output load shall be a 50 ohm resistive term. on having a voltage standing wave ratio of 1.1 or less, including connectors and cables, at the standard test frequency (par. 5.1.4).

5.2.9 Deviation Meter

The deviation meter shall be capable of measuring the peak deviation of a modulated waveform with an uncertainty no greater than 5 percent of the deviation being measured.

5.2.10 Standard Audio Output Load

The standard audio output load shall be a resistor having a resistance equal to the nominal output impedance of the receiver/decoder and a power rating equal to or exceeding the nominal output power. A filter network shall not be used between the audio output terminals and the audio output load. If an external monitor speaker is used, a matching network to maintain the standard output load impedance at the audio output terminals shall be provided.

5.2.11 Audiofrequency Voltmeter

The audiofrequency voltmeter shall measure the true rms value of the input signal for all waveforms with crest factors (ratio of peak to rms amplitude of the input signal) up to 10 to 1 at full scale. The measurement uncertainty shall be 2 percent or less for input signals with frequency components in the range of 300 to 5000 Hz.

5.2.12 Environmental Chamber

The environmental chamber shall produce air temperatures from $-30\text{ }^{\circ}\text{C}$ to $60\text{ }^{\circ}\text{C}$ ($-22\text{ }^{\circ}\text{F}$ to $140\text{ }^{\circ}\text{F}$) and relative humidities in excess of 90 percent. The test items shall be shielded from air currents blowing directly from heating or cooling elements in the chamber. The temperature of the test item shall be measured with a thermometer separate from the sensor used to control the chamber air temperature. Likewise, humidity shall be measured with a hygrometer separate from the sensor used to control humidity.

5.3 Environmental Tests

5.3.1 Temperature Test

Place the equipment under test, with outer cases installed and with power turned off, in the environmental chamber. Adjust the chamber to the required low temperature $\pm 2\text{ }^{\circ}\text{C}$ ($\pm 3.6\text{ }^{\circ}\text{F}$). Allow the equipment to reach temperature equilibrium and maintain it at this temperature for 30 minutes. Turn on the power to the equipment under test. Fifteen minutes after turn-on, test the equipment to determine whether it meets the requirements of paragraph 4.4.1. Repeat the above procedure at the required high temperature $\pm 2\text{ }^{\circ}\text{C}$ ($\pm 3.6\text{ }^{\circ}\text{F}$).

5.3.2 Humidity Test

Place the equipment under test, with power turned off, in the environmental chamber. Adjust the relative humidity to a minimum of 90 percent at $50\text{ }^{\circ}\text{C}$ ($122\text{ }^{\circ}\text{F}$) and maintain the equipment at these conditions for at least 8 hours. While it is still in this environment, turn on the equipment power, allow it to operate for 15 minutes, and then test it to determine whether it meets the requirements of paragraph 4.4.2.

5.3.3 Vibration Test

Perform a two-part test for a total of 30 minutes in each of three mutually perpendicular directions, one of which is the vertical.

First subject the equipment under test to three 5-minute cycles of simple harmonic motion having an amplitude of 0.38 mm (0.015 inch) [total excursion of 0.76 mm (0.03 inch)] applied initially at a frequency of 10 Hz and increased at a uniform rate to 30 Hz in 2 1/2 minutes, then decreased at a uniform rate to 10 Hz in 2 1/2 minutes.

Then subject the equipment to three 5-minute cycles of simple harmonic motion having an amplitude of 0.19 mm (0.0075 inch) [total excursion of 0.38 mm (0.015 inch)] applied initially at a frequency of 30 Hz and increased at a uniform rate to 60 Hz in 2 1/2 minutes, then decreased at a uniform rate to 30 Hz in 2 1/2 minutes.

Repeat for each of the other two directions.

5.3.4 Shock Test

Subject the equipment to a series of ten impacts in each of the three mutually perpendicular directions (par. 5.3.3), each impact to consist of a half sine wave acceleration of 20 g peak amplitude and 11 milliseconds duration. Apply the impacts to the equipment mounting facilities, if there are any.

5.4 Radio Receiver/Decoder Tests

5.4.1 Pre-Transmission Monitoring Test

Connect the equipment as shown in figure 2. Set the FM signal generator to the standard test frequency, modulate with standard test modulation and adjust the generator output to 1 mV. Disable the decoder with the decoder-disable switch, set the squelch control to the maximum unsquelch position, and adjust the receiver to produce rated audio output power. Confirm that an output is present on the ac voltmeter. Release the decoder-disable switch and confirm that the receiver is now squelched and the ac voltmeter measures no output.

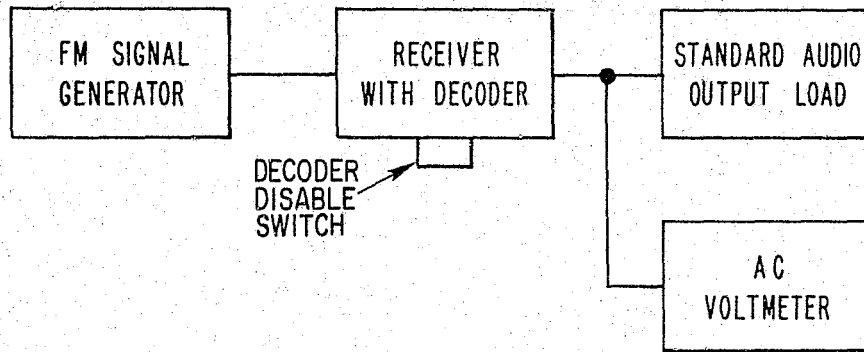

FIGURE 2. Block diagram for pre-transmission monitoring capability measurement.

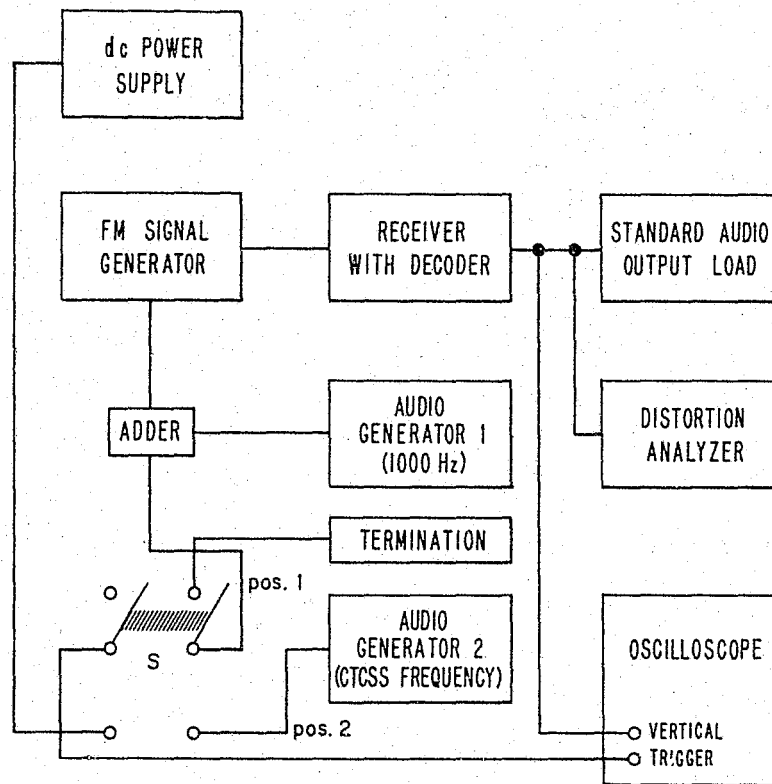

FIGURE 3. Block diagram for CTCSS receiver response time and decoder response bandpass measurement.

5.4.2 Receiver Response Time Tests

5.4.2.1 CTCSS

Connect the equipment as shown in figure 3 with switch S in position 2, and adjust the frequencies and output levels of audio generators 1 and 2 to produce standard test modulation and CTCSS test modulation, respectively. Adjust the FM signal generator output to 1 mV at the standard test frequency.

Adjust the oscilloscope trigger controls to start the trace when switch S is moved from position 1 to 2. Then move the switch between positions 1 and 2 several times while adjusting the horizontal sweep controls so that the

change in audio level can be easily determined as a function of time. Adjust the oscilloscope vertical sensitivity to produce nearly full scale deflection when the audio voltage becomes steady state.

Move switch S from position 1 to 2 and read the time in milliseconds between the start of the oscilloscope trace and the time at which the audio voltage at the receiver output reaches 90 percent of its final value. This is easy to read if the instrument is a storage oscilloscope. If it is not, it may be necessary to photograph the trace.

5.4.2.2 CDCSS

Connect the equipment as shown in figure 4 with switch S in position 2, and adjust the frequency and output level of audio generator 1 to produce standard test modulation. Adjust the code generator output level to produce the value of CDCSS test modulation recommended by the manufacturer. Adjust the FM signal generator to an output of 1 mV at the standard test frequency.

Adjust the oscilloscope trigger controls to start the trace when switch S is moved from position 1 to 2. Move the switch between positions 1 and 2 several times while adjusting the horizontal sweep controls so that the change in audio level can be easily determined as a function of time. Adjust the oscilloscope vertical sensitivity to produce nearly full scale deflection when the audio voltage becomes steady state.

Move switch S from position 1 to 2 and read the response time as detailed in paragraph 5.4.2.1.

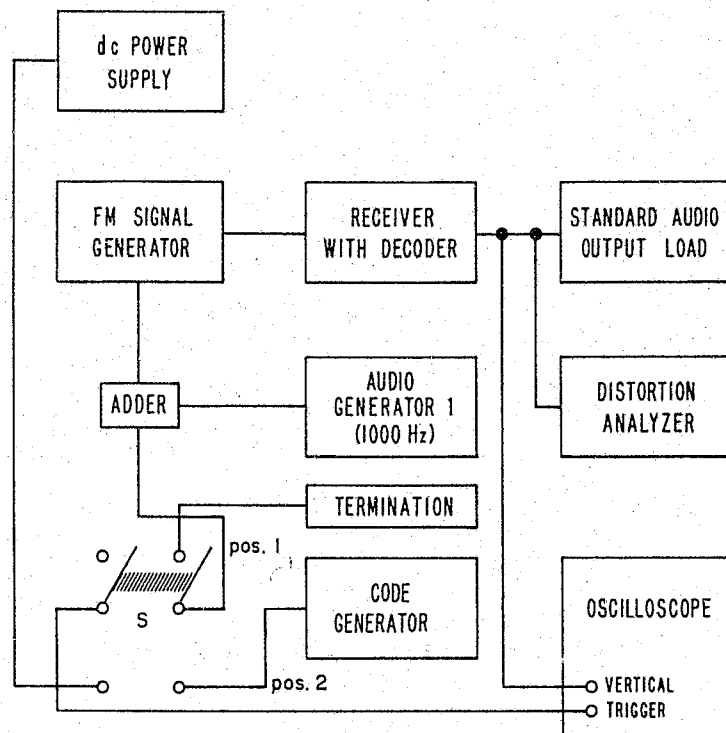

FIGURE 4. Block diagram for CDCSS receiver response time and squelch opening SINAD measurements.

5.4.3 Squelch Opening SINAD Ratio Tests

5.4.3.1 CTCSS

Connect the equipment as shown in figure 5, set the FM signal generator to the standard test frequency, and modulate it with CTCSS test modulation using audio generator 2 and with standard test modulation using audio generator 1. Adjust the receiver squelch control to the threshold squelch position and the receiver volume control to produce nominal audio output power with a 1 mV input signal.

Reduce the input signal level until the receiver squelch closes. Then increase the input signal until the receiver produces continuous audio output not lower than 10 dB below nominal audio output power. Measure the SINAD (CTCSS) ratio at this rf signal level using the distortion analyzer.

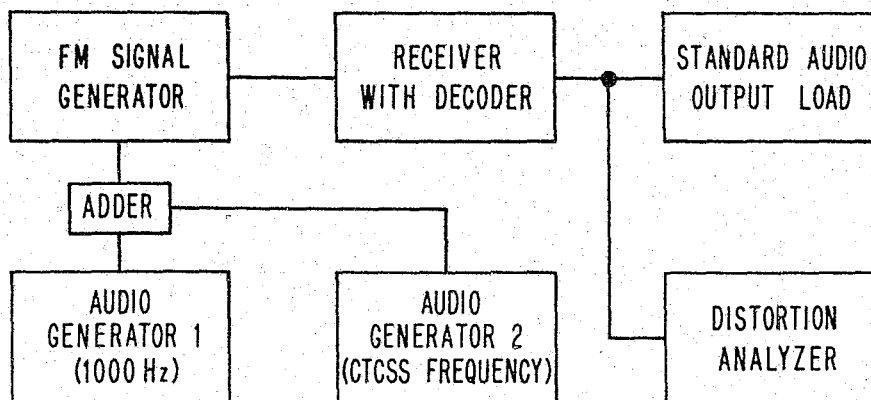

FIGURE 5. Block diagram for CTCSS squelch opening SINAD measurement.

5.4.3.2 CDCSS

Connect the equipment as shown in figure 4, with switch S in position 2, set the FM signal generator to the standard test frequency, and modulate it with CDCSS test modulation using the code generator and with standard test modulation using audio generator 1. Adjust the receiver squelch control to the maximum unsquelch position and the receiver volume control to produce nominal audio output power with a 1 mV input signal.

Set the receiver input signal level to a value that produces a SINAD (CDCSS) ratio of 10 dB. With this input, measure the receiver response time as detailed in paragraph 5.4.2.1. Repeat the response time measurement 100 times or more. At least 90 percent of the measurements must give a response time of less than 1 second.

5.4.4 Decoder Response Bandpass Test (CTCSS)

Connect the equipment as shown in figure 3 and repeat the measurement procedure given in paragraph 5.4.2.1, but with audio generator 2 adjusted to produce a frequency 0.5 percent above the CTCSS test modulation. An audio output must be observed in less than twice the maximum receiver response time given in (item A) of table 1. Repeat the measurement, but with a frequency 0.5 percent below the CTCSS test modulation. An audio output must be observed in less than twice the maximum receiver response time given in (item A) of table 1.

Repeat the measurement, but with a frequency 3.0 percent above the CTCSS test modulation. No output may appear within a test period of 1 minute. Repeat the measurement, but with a frequency 3.0 percent below the CTCSS test modulation. No output may appear within a test period of 1 minute.

5.4.5 Receiver Hum and Noise Tests

5.4.5.1 CTCSS

Connect the equipment as shown in figure 6, and adjust the frequencies and output levels of audio generators 1 and 2 to produce standard test modulation and CTCSS test modulation.

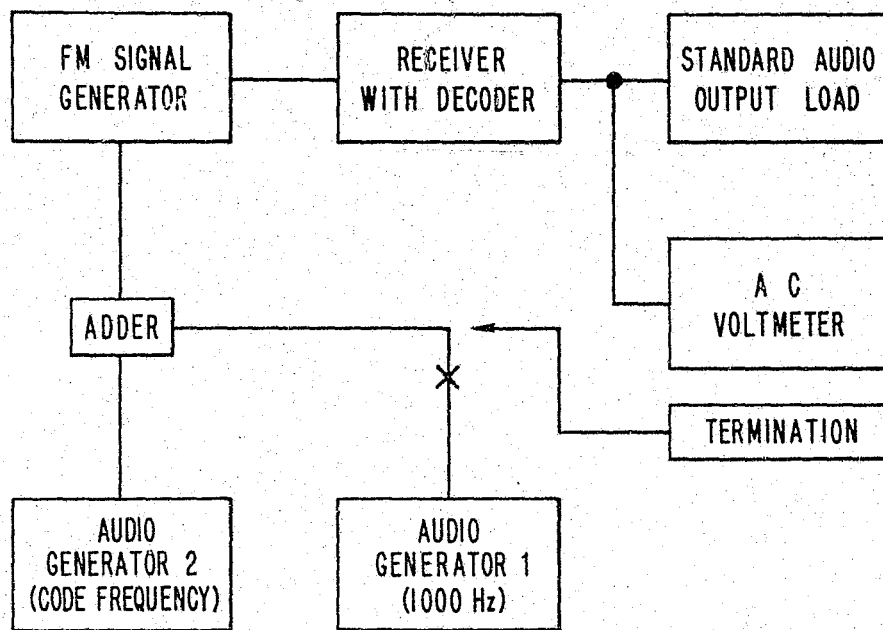

FIGURE 6. Block diagram for CTCSS receiver hum and noise measurement.

Adjust the FM signal generator to an output of 20 V at the standard test frequency. Set the receiver volume control for nominal audio output power as determined with the ac voltmeter.

Remove the standard test modulation by replacing audio generator 1 with a termination equal to its output impedance. Measure the decrease in the audio signal, expressed in dB, by means of the ac voltmeter.

5.4.5.2 CDCSS

Connect the equipment as shown in figure 7, and adjust the frequency and output level of audio generator 1 to produce standard test modulation. Adjust the code generator output level to produce the value of CDCSS test modulation recommended by the manufacturer.

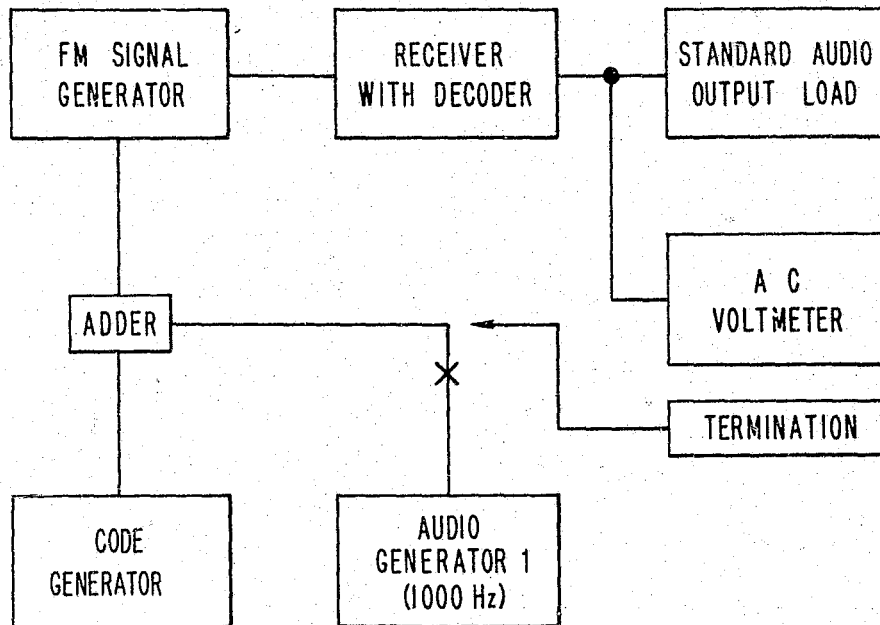

FIGURE 7. Block diagram for CDCSS receiver hum and noise measurement.

Adjust the FM signal generator to an output of 20 V at the standard test frequency. Set the receiver volume control for nominal audio output power as determined with the ac voltmeter.

Remove the standard test modulation by replacing audio generator 1 by a termination equal to its output impedance. Measure the decrease in the audio signal, expressed in dB, by means of the ac voltmeter.

5.4.6 Decoder Tolerance to Bias Distortion Test (CDCSS)

Connect the equipment as shown in figure 8. To calibrate the pulse distorting unit, connect the square wave generator in place of the code generator. The square wave generator output must be symmetrical, with the higher voltage (mark) and lower voltage (space) parts of the wave equal in duration and each part equal to the bit length of the code from the code generator. The amplitude of the square wave pulses should be approximately equal to that of the code pulses.

While observing the output of the distorting unit on the oscilloscope, adjust the distorting unit for a mark bias distortion that produces an output wave with the mark 2.6 times as long as the space. This is equivalent to a 45 percent mark bias distortion.

Replace the square wave generator with the code generator. Set the CDCSS test modulation at its lowest limit, that is, at the amplitude that will produce a carrier frequency deviation of 0.5 kHz. Adjust the FM signal generator to the standard test frequency and its output voltage to the value corresponding to a 10 dB SINAD (CDCSS) ratio, as determined earlier (par. 5.4.3.2). The receiver squelch must open as evidenced by receiver output noise.

Repeat the test for 45 percent space bias distortion by adjusting the distorting unit to produce an output wave with the space 2.6 times as long as the mark.

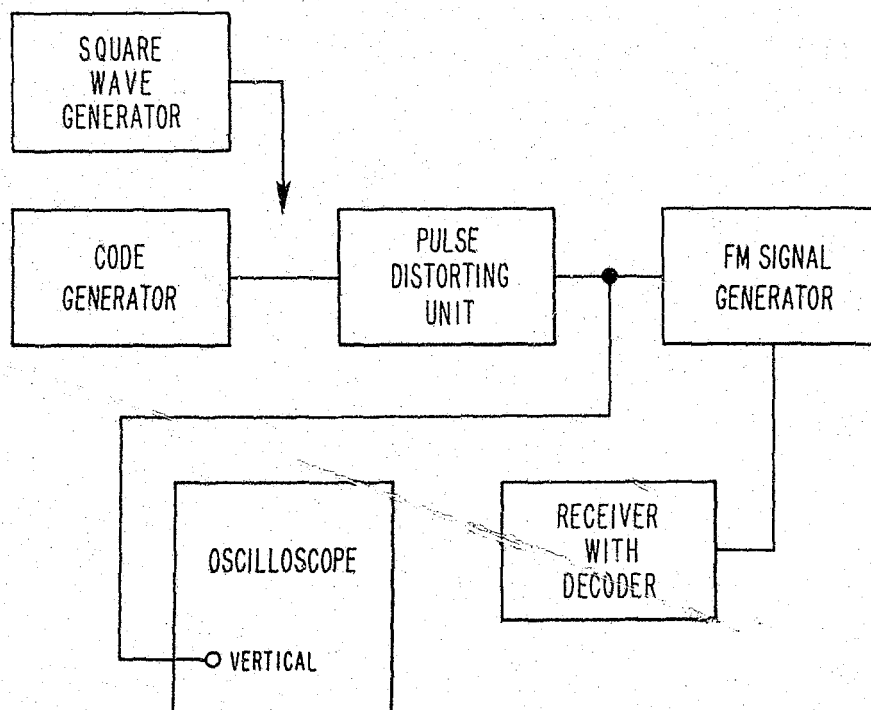

FIGURE 8. Block diagram for CDCSS decoder tolerance to bias distortion measurement.

5.5 Radio Transmitter/Encoder Tests

5.5.1 Modulation Code Tolerance and Stability Tests (CTCSS)

Connect the equipment as shown in figure 9. Operate at standard power supply voltage for one minute, and use the counter to measure the value of and the stability of the period of the modulation code. Repeat the measurement at power supply voltages 20 percent above and 20 percent below the standard voltage. Take the reciprocal of the period in seconds to obtain the frequency in Hz.

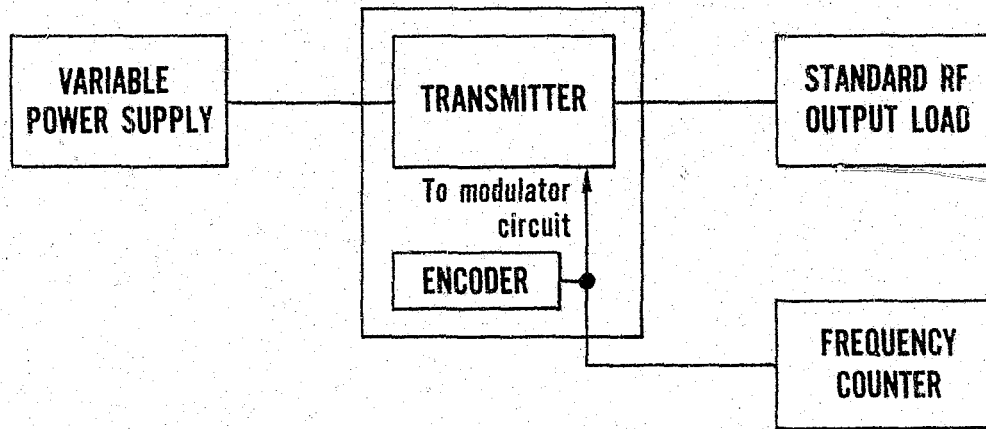

FIGURE 9. Block diagram for CTCSS modulation code tolerance and stability measurements.

5.5.2 Code Modulation Deviation Test (CTCSS and CDCSS)

Connect the equipment as shown in figure 10, without standard test modulation. Energize the encoder and measure the modulation deviation with the deviation meter.

5.5.3 Encoder Response Time Tests

5.5.3.1 CTCSS

Connect the equipment as shown in figure 11. Adjust the oscilloscope trigger controls so that the transmitter keying pulse will trigger them. Adjust the vertical sensitivity to produce a nearly full scale display on the oscilloscope when the encoder is furnishing constant output. Adjust the oscilloscope horizontal sweep controls for a readable time display by pushing the push-to-talk button several times.

Photograph the display when the push-to-talk button is pushed and determine the time in milliseconds it takes for the CTCSS encoder output voltage to reach 90 percent of its final value. If a storage oscilloscope is used, it may be read directly and the photograph will not be necessary.

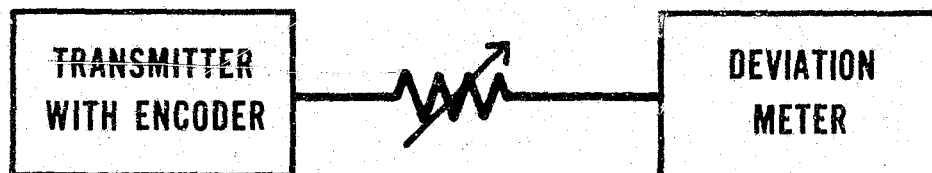

FIGURE 10. Block diagram for code modulation deviation measurement.

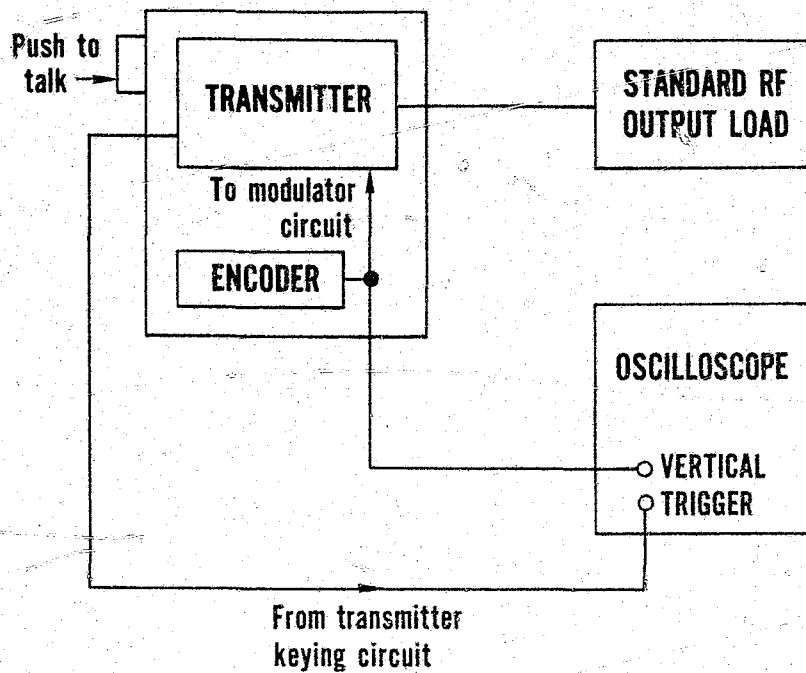

FIGURE 11. Block diagram for encoder response time measurement.

5.5.3.2 CDCSS

Proceed as in paragraph 5.5.3.1, but determine the time in milliseconds it takes for the number 1 bit of the sequence to appear in the CDCSS encoder output. If any code bits appear before the number 1, they should be ignored. The number 1 bit can be identified by displaying the code on the oscilloscope and comparing it with the sequence furnished by the manufacturer.

5.5.4 Transmitter Tone Distortion Test (CTCSS)

Connect the equipment as shown in figure 12. With no standard test modulation applied, adjust the encoder to modulate the transmitter. Tune the standard test receiver to the transmitter carrier frequency and measure harmonic distortion of the CTCSS modulation code at the receiver de-emphasized discriminator output.

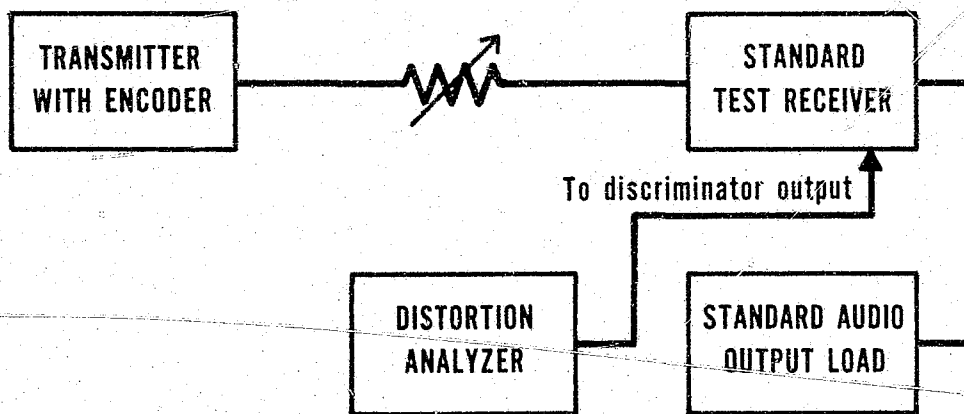

FIGURE 12. Block diagram for CTCSS transmitter tone distortion measurement.

5.5.5 Transmitter Total Distortion Test (CTCSS)

Connect the equipment as shown in figure 13. Modulate the transmitter with standard test modulation from audio generator 1 and CTCSS modulation code from the encoder. Tune the standard test receiver to the transmitter carrier frequency. Adjust distortion analyzer 1 to filter out the CTCSS modulation code and apply the filtered distortion analyzer output to distortion analyzer 2. Measure the total distortion of the transmitter using distortion analyzer 2.

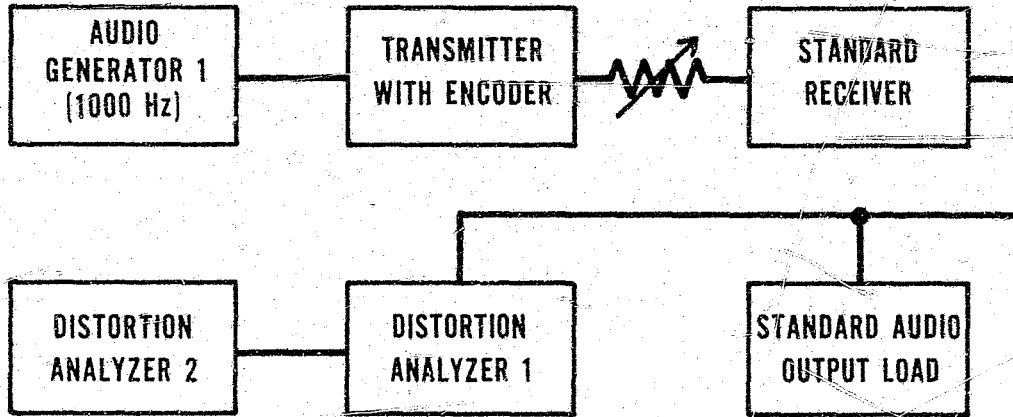

FIGURE 13. Block diagram for CTCSS transmitter total distortion measurement.

5.5.6 Encoder Clock Stability Test (CDCSS)

Connect the equipment as shown in figure 14. Measure the clock period on the frequency counter at standard power supply voltage and take the reciprocal to obtain the encoder clock frequency. Repeat at voltages 20 percent above and 20 percent below the standard power supply voltage.

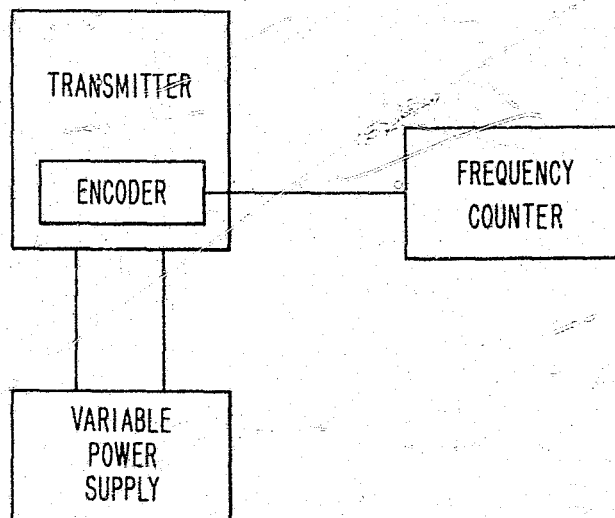

FIGURE 14. Block diagram for CDCSS encoder clock stability measurement.

5.5.7 Encoder Clock Jitter Test (CDCSS)

Connect the equipment as shown in figure 15, and adjust the frequency synthesizer to the encoder clock frequency. Trigger the oscilloscope externally on the synthesizer frequency. Adjust the oscilloscope time base controls so that at least 10 microseconds can be measured. Observe the maximum phase jitter on the oscilloscope for a period of one minute. Record the maximum value.

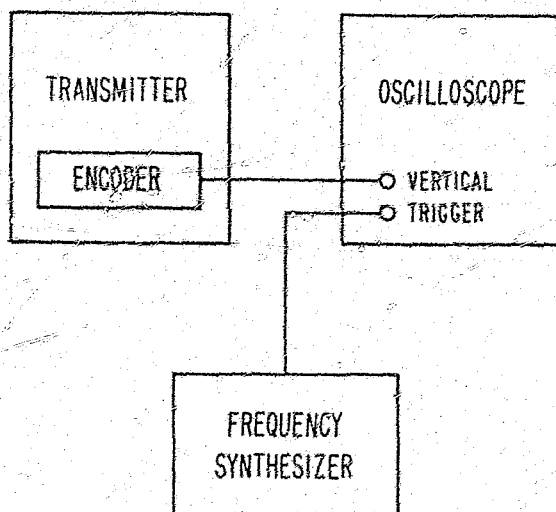

FIGURE 15. Block diagram for CDCSS encoder clock jitter measurement.

BIBLIOGRAPHY

1. Buesing, R. T., Botherance Rejection with Double-Barreled Channel Guard, IRE Trans., Vol. PGVC-10, pp. 7-15 (April 1958).
2. EIA Standard RS-220-A, Continuous Tone-Controlled Squelch Systems (CTCSS) (March 1979).
3. Hamsher, D. H., Editor, Communications System Engineering Handbook, Chapter 17, pp. 40-47 McGraw-Hill Book Co., Inc., New York, NY, 1967).
4. Hurt, G. F., Tone-coded Squelch in Government Land Mobile Communications, Office of Telecommunications Technical Memorandum (April 1976).
5. LESP-RPT-0203.00, "Technical Terms and Definitions Used With Law Enforcement Communications Equipment (Radio Antennas, Transmitters, and Receivers)," Superintendent of Documents, U.S. Government Printing Office, Washington, DC 20402, Stock No. 2700-09214 (June 1973).
6. MX 300 Series, "Handie-Talkie" Portable FM Two-Way Radios, Motorola, Inc. Instruction Book 68P81007C10-0.
7. NILECJ-STD-0201.00, "NILECJ Standard for Fixed and Base Station FM Transmitters," Superintendent of Documents, U.S. Government Printing Office, Washington, DC 20402, Stock No. 2700-00283 (September 1974).
8. NILECJ-STD-0202.00, "NILECJ Standard for Mobile FM Transmitters," Superintendent of Documents, U.S. Government Printing Office, Washington, DC 20402, Stock No. 2700-00287 (October 1974).
9. NILECJ-STD-0206.00, "NILECJ Standard for Fixed and Base Station FM Receivers," Superintendent of Documents, U.S. Government Printing Office, Washington, DC 20402, Stock No. 027-000-00358-3 (September 1975).
10. NILECJ-STD-0207.00, "NILECJ Standard for Mobile FM Receivers," Superintendent of Documents, U.S. Government Printing Office, Washington, DC 20402, Stock No. 027-000-00344-3 (June 1975).
11. NILECJ-STD-0209.00, "NILECJ Standard for Personal FM Transceivers," Superintendent of Documents, U.S. Government Printing Office, Washington, DC 20402, Stock No. 027-000-00728-0 (December 1978).

END