

7

LAW ENFORCEMENT ASSISTANCE ADMINISTRATION (LEAA)

POLICE TECHNICAL ASSISTANCE REPORT

SUBJECT:

Assistance in the Development of a
Closed Circuit TV Security System
and Bid Specifications for a Municipal
Jail Facility.

REPORT NUMBER:

76-127-077

FOR:

City of Delano, California

CONTRACTOR:

Public Administration Service
1776 Massachusetts Avenue, N.W.
Washington, D. C. 20036

CONSULTANT:

Mr. Jarvis Williams

CONTRACT NUMBER:

J-LEAA-002-76

DATE:

August, 1976

36427

NCJRS

SEP 14 1976

ACQUISITIONS

Table of Contents

	<u>Page</u>
I. INTRODUCTION	1
II. CLOSED CIRCUIT TELEVISION SYSTEM DESIGN AND BID SPECIFICATIONS	2
1. Sally Port	2
2. Booking Area	3
3. North, South and East Corridor Cameras	4
4. Jail Office	4
5. Prisoner Preparation	4
6. Drunk Tank	5
7. Isolation Cell	6
8. North and South Four Man Cells	6
9. Front Police Communications and Reception Offices .	6
10. General Discussion	8

Exhibits

SK-1	Systems Drawing	10
SK-2	Location Drawing	11
SK-3	Discreet Protective Enclosure for Drunk Tank and Isolation Cell	12
SK-4	Proposed Equipment Layout and Recommended Electrical	13

INTRODUCTION

The following report addresses a technical assistance request for the City of Delano, California to adopt closed circuit television to a new jail facility. The jail area is small in dimension and is characterized by medium to low light levels.

The City has undertaken some previous planning with respect to the desired locations to be observed, and 110/60 electrical service and conduits for transmission cables have been installed. In many cases, however, the planned locations are not ideal.

The following report describes where and how the cameras should be located, and provide a location by location specification. The specification indicates what light levels the camera must operate in, the type of lens, enclosures and method of mounting, and a complete systems description to define the system logic suited to the proposal. The format for the report is typical of a closed circuit television specification.

On-site technical assistance was provided by the consultant on July 19, 1976. During the site visit the consultant conducted interviews with, and received assistance from, Mr. Nicholas Slaughter, City Controller, and Mr. Jimmie Perkins, Senior Officer.

CLOSED CIRCUIT TELEVISION
SYSTEM DESIGN AND BID SPECIFICATIONS

To accomplish the results intended, twelve (12) video cameras are proposed. Locations of cameras and monitor equipment are listed as follows. Note: See SK1 enclosed for systems drawings and SK2 for location drawings.

1. Sally Port (One Camera)

- a. Camera shall be one inch vidicon type and operate on 24VAC, with center resolution of 600 lines, signal to noise ratio of 48db. The horizontal blanking/synchronizing interval of the video output wave form shall include front and back porches, conforming to EIA standard RS-170, this requirement should be met when camera is operating in the random mode.
- a.1. Video level control shall be by manual or automatic means by a rear panel switch. The automatic level control (ALC) shall maintain the video portion of the output signal at $0.714V \pm 3db$ over a 40,000 to one variation in faceplate illumination.
- a.2. Camera size is important in that it should be as small dimensionally as possible. As service ability is of the utmost value, 100% of the circuit components must be accessible while camera is operational and with the cover removed. All circuit boards should be made of glass epoxy material and be plug-in types.
- a.3. Camera shall perform with no distortion or variance in picture quality over a temperature range of -20 to +60 degrees C, line voltage variation between 100 to 130VAC and faceplate highlight illumination levels of 0.1 to 1,000 foot candles when operating with ALC; also .01 foot candle faceplate illumination shall provide specified video output.
- a.4. Camera shall incorporate a window shade feature for disabling the ALC within a controlled portion of the picture, the controlled portion shall begin at the top and be internally adjustable to within 25% of the bottom of the picture. A switch shall be provided to temporarily insert a position marker in the video output to facilitate window shade adjustment.
- a.5. Camera shall incorporate a white clipper circuit to limit the video portion of the output wave form to $1.0V \pm 0.1V$ under all camera operating and picture content conditions.

- a. 6. Camera shall have a built-in audio monitor consisting of a microphone coupled to an aperture at the front of the camera with an amplifier having 60db AGC range and a modulator that provides either a 4.5 or 10.7 mhz FM modulated carrier added to the camera video output. Because the FM modulated carrier is added to the camera video output no added cabling is required. The FM audio signal is then recovered from the video signal by a single audio receiver.
- a. 7. The audio receiver FM output signal shall be terminated in 75 ohms, have a 65MV output level, 4.5 mhz center frequency with ± 25 Khz deviation with constant tone. Audio bandpass 3db down at 300HZ and 2000HZ and operates on internal +12V, and having integral volume control.

Note: Should the bidding party need further specifications, this unit is a standard design. Specifics may be obtained upon request.

- b. Lens shall be C mount 12.5mm F1.4.
- c. Housing shall be weatherproof, complete with fan, thermostat and heater. Fan shall operate continuously, and be located to allow constant flow of air throughout the enclosure. Fan should be rated to allow approximately 40 air changes each minute. Heater shall operate "on" at 50 degrees F and "off" at 60 degrees F. Main purpose of heater and fan is to reduce moisture in camera.
- d. Mount. Camera shall be located at N. W. corner of Sally Port facing in an outward direction. Camera and housing to be mounted on a fixed heavy duty bracket with swivel head, allowing easy adjustment.
- e. Comments. The Sally Port camera will look out into the light of day. This means the upper portion of the picture will be very bright as compared to a darker lower half. The window shade feature is very important to the operation of this camera. To compensate for low light level in darkness, a diffused 250 watt fixture should replace the existing "spot" lamp now being used, or a diffused lamp and fixture should be added to this area.

2. Booking Area (One Camera)

- a. Camera specifications to be same as 1. a. through a-7. above, except without window shade (a-4.)

- b. Lens shall be C mount 6mm F1.8.
- c. Housing. None required.
- d. Camera to be mounted on a fixed medium duty bracket with swivel head, to allow for easy adjustment. (See SK2 for location)

3. North, South and East Corridor Cameras (Four Cameras)

- a. Camera specifications to be same as 1. a. through a-7. above, except without window shade (a-4.)
- b. Lens shall be C mount 12.5mm F1.4.
- c. Housing, protective metal, dust tight, with glass viewing port. (See comments)
- d. Same as 2.d. above, see SK2 for location.
- e. Comments: It would be desirable to mount cameras recessed into walls to provide greater frontal visibility mainly for West facing North and South corridor cameras; also for all cameras to eliminate crowding due to small amount of available space.

4. Jail Office (One Camera)

- a. Camera specifications to be same as 1. a. through a-7. above.
- b. Lens shall be C mount 12.5mm F1.4.
- c. Housing. Not required.
- d. Same as 2.d. above see SK2 for location.
- e. Comments: Use window shade, same as in 1 above.

5. Prisoner Preparation (One Camera)

- a. Camera specifications same as 1. a. through a-7. above except without window shade (a. 4.)
- b. Lens shall be C mount 6mm F1.8.
- c. Housing. Not required.
- d. Same as 2.d. above see SK2 for location.

6. Drunk Tank (One Camera)

- a. Camera shall be one inch silicon diode vidicon and to operate on 24VAC, with center resolution of 600 lines, signal to noise ratio of 48db or better. The horizontal blanking/synchronizing interval of the video output wave form shall include front and back porches, conforming to EIA standard RS-170, this requirement should be met when camera is operating in the random mode.
- a-1. When ALC switch is in manual position, camera shall be capable of controlling the gain of the video amplifier over a range of 30db. When in auto ALC position, video level shall be maintained over a 30:1 range of faceplate illumination.
- a-2. Camera size is important in that it should be as small dimensionally as possible. As serviceability is of the utmost value, 100% of the circuit components must be accessible while camera is operational and with the cover removed. All circuit boards should be made of glass epoxy material and be plug-in type.
- a-3. Camera shall operate with no distortion or variance in picture quality over a temperature range of -4 degrees to +140 degrees F and from 100 to 130VAC without adjustment, also 0.003 foot candles faceplate illumination shall produce specified output level. Camera shall have automatic black level and be gamma corrected.
- a-4. Camera shall have a built-in audio monitor consisting of a microphone coupled to an aperture at the front of the camera with an amplifier having 60db AGC range and a modulator that provides either a 4.5 or 10.7 mhz FM modulated carrier added to the camera video output. Because the FM modulated carrier is added to the camera video output, no added cabling is required. The FM audio signal is then recovered from the video signal by a single audio receiver.
- a-5. The audio receiver FM output signal shall be terminated in 75ohms, have a 65MV output level, 4.5mhz center frequency with ± 25 Khz deviation with constant tone. Audio bandpass 3db down at 300Hz and 2000Hz and operates on internal +12V and have integral volume control.
- Note: Should the bidding party need further specifications, this unit is a standard design. Specifics may be obtained upon request.
- b. Lens shall be C mount 6.5mm F1.8 with manually adjustable iris.

- c. Housing-special housing to be provided to fit into matching light fixture less lamp as is now utilized in Drunk Tank. This fixture shall be equipped with a high reflective mirror from which the camera will view the area below. The viewing port can be a heavy gauge wire mesh. See SK3 for details.

Note: When mirrors are used with video cameras, the picture must be inverted. This can, and must be done. Simply reverse the deflection coil leads, or rotate the yoke 180 degrees to accomplish this.

- d. Special mounting -- See SK2 for location.
- e. Use rigid conduit for any added cables, take care to install with security hardware, headless bolts, etc.

7. Isolation Cell (One Camera)

- a. Camera specifications same as 6.a. through a-5. above.
- b. Lens shall be C mount 6.5mm, F1.8 with manually adjustable iris.
- c. Housing same as 6.c. above.
- d. Same as 6.d. above.
- e. Same as 6.e. above.

8. North and South Four Man Cells (Two Cameras, one in each cell)

- a. Camera specification same as 6.a. through a-5. above.
- b. Lens shall be C mount 6.5mm F1.8 with manually adjustable iris.
- c. Housing-protective metal dust tight with glass viewing port.
- d. Same as 2.d. above.
- e. Comments: Camera housings should be painted black or dark gray to provide a more discreet presence.

9. Front Police Communications and Reception Offices (Monitor Location)

Because of the obvious lack of physical space, monitors, sequential switchers, and VTR equipment will be mounted on a rigidly supported shelf located on the north office wall. Equipment to be located here is as follows:

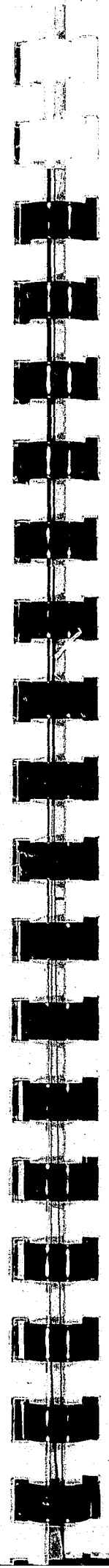

- a. Monitors -- four required to be ten inch diagonal with center horizontal resolution of 640 lines. All controls to be front accessible to have regulated power supply and fast AFC circuit for good helical scan VTR display. To operate on 110/60hz with 3 wire line cord, to have continuous DC restoration, 10KV nominal CRT high voltage, 75 ohm termination and high impedance bridging with connector for looping.

Approximate size, 9" x 9" x 11" with hooded cabinet. All circuits to be 100% solid state and to have plug-in circuit modules for easy service.

- b. Sequential switchers -- four required each unit shall contain four positions to allow for future expansion. The sequential device shall be full solid state and mounted into a desk top enclosure approximately 2" high, 6" wide and 10" deep, to fit the shelf arrangement for the four monitors. The switch shall be capable of automatically switching from each camera in a continuous cycle. When a position is to be locked out, this will be done manually by switching to the bypass mode for that position. A third switch position shall provide for stopping on any camera which may be desired. The switcher shall use indicator lamps allowing operator to see which camera is displayed at any time. Switcher shall also pass audio without distortion as well as video.
- c. Power supply -- a 110/60hz to 24/60hz 500 VA transformer shall be provided and connected directly to the same service which is to feed the monitors and sequential switcher and any future components (eg) video tape recorder. All electrical distribution shall originate at this location to insure proper synchronization for the entire system. This will prevent any instability that may result, causing vertical or horizontal distortion. All electrical wiring to cameras shall originate from this transformer. All wiring to cameras should be number 12RH or standard local code insulation.

Transformer should be enclosed in Nema I housing with terminals or lugs for external connection. All power for CCTV system should be isolated from other building circuits.

- d. Options: A video tape recorder may be desired. This recorder shall be $\frac{1}{2}$ " with automatic video and audio AFC and gain control. Recorder shall be $\frac{1}{2}$ " reel to reel and be capable of recording and playback in one hour using 2400 foot $\frac{1}{2}$ " video tape. Recorder can be any one of a number of well-known manufacturers.

An optional video preview monitor will be required. This monitor will conform to the same specifications listed above, for monitors, only it will have a tuner. This will allow both audio and video to be played back.

Note: To record into the VTR, a manual selector switch will be required. This will allow recording any one of the twelve (12) cameras which might be selected. This switch should be a 12 position passive device, designed for switching video signals.

- e. Comments: Refer to systems drawing SK1 for equipment layout. Name plates shall be affixed to each sequential switcher to indicate which camera is being displayed, as it is desired to connect the cameras on a pre-established sequence mode. The diagram shows the pre-established designations for each switcher and camera combination.

10. General Discussion

- a. A single RG-59U double shielded coaxial cable and two no. 12 less ground cable will be routed to each camera. The systems design is such that all equipment should be purchased from one professional video surveillance systems supplier. All cameras specified are made by various manufacturers. It is desirable that all cameras be from one manufacturer for better serviceability. Monitors and sequential switchers will be manufactured by various companies as an item should be from the same manufacturer.
- b. Total estimated installed cost including options approximates \$30,000.00. This includes a 10% allowance over and above the actual installed cost to allow for local variances in pricing.
- c. California based firms from whom you might request bids for this job are as follows:

Note: The writer accepts no responsibility for, or in any way has any knowledge of the following firms. This list is supplied to the City of Delano at their request due to their total unfamiliarity with firms who may offer bids. The writer has no interest whatsoever in any of these firms, and can not pass judgment as to their ability to meet the above specifications.

1. Acromedia
5664 Selmarain Drive

Culver City, California 90230
(213) 390-4407

2. Video Systems, Inc.
12530 Beatrice
Los Angeles, California 90066
(213) 390-4039
3. You might also look in the Bakersfield yellow pages.

EXHIBITS

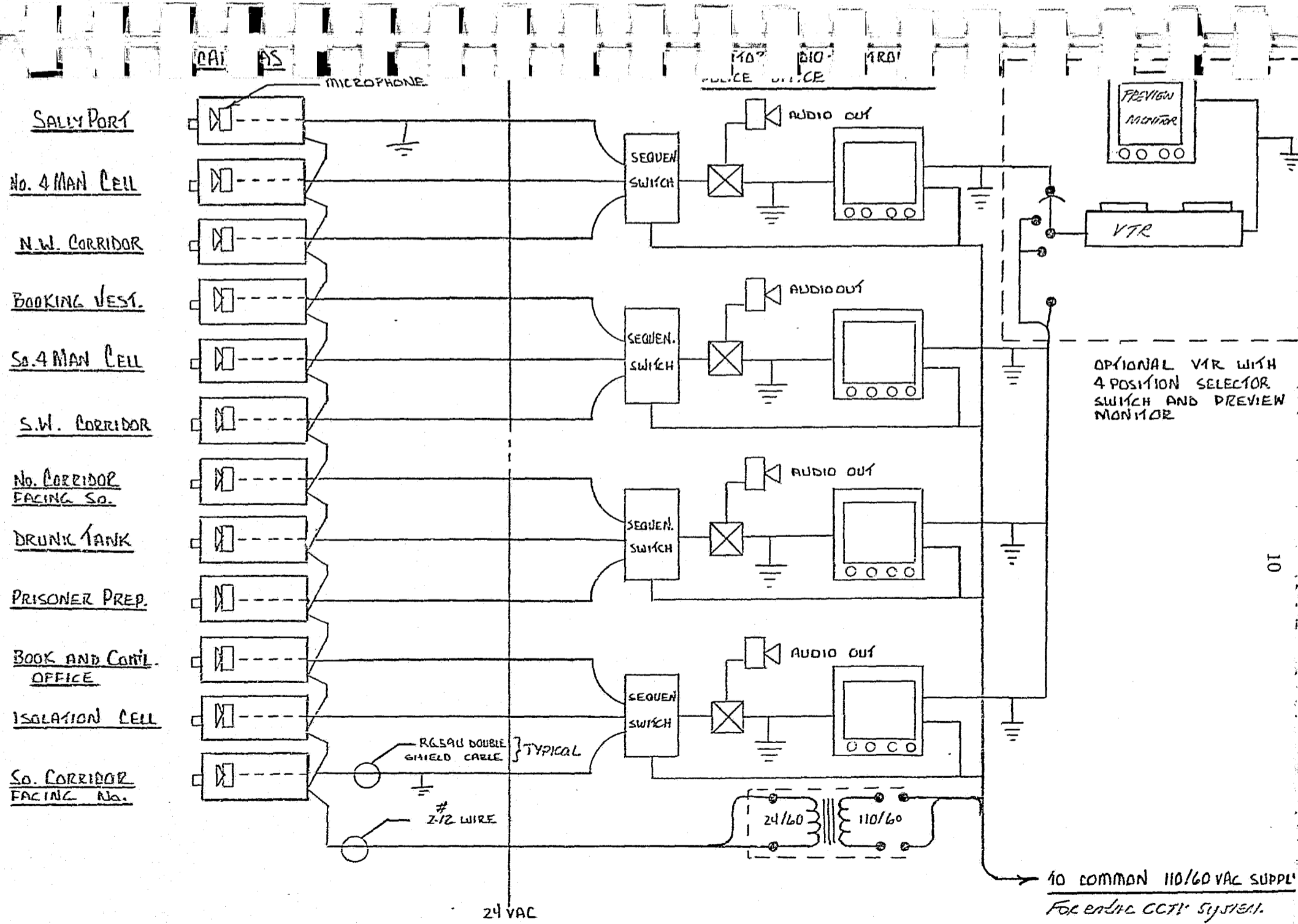

OPTIONAL VTR WITH
4 POSITION SELECTOR
SWITCH AND PREVIEW
MONITOR

110 COMMON 110/60 VAC SUPPLY
For entire CCTV SYSTEM.

7-28-76
SK-1

SYSTEMS DRAWING
DELANO CHY SAIL

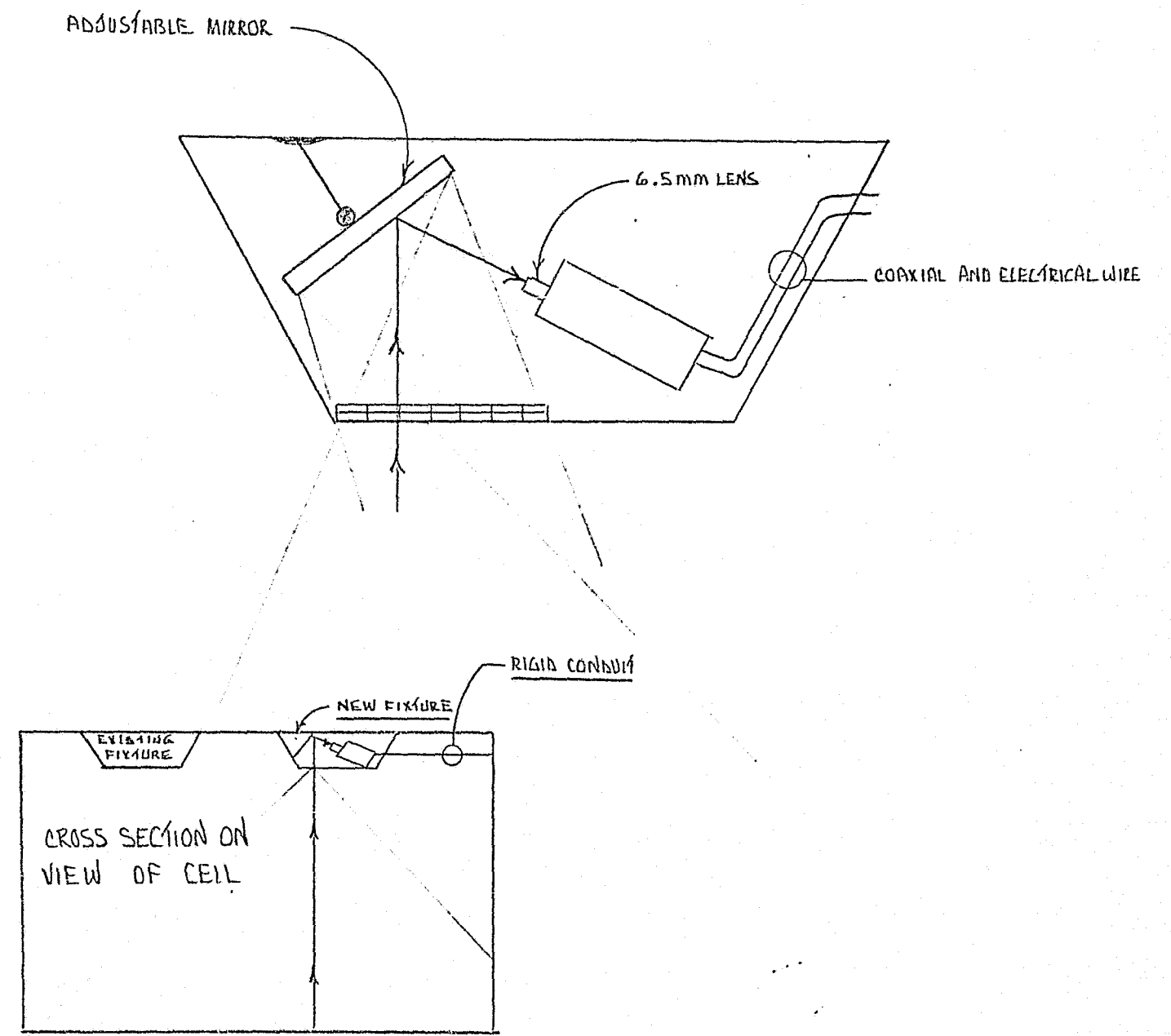

SK-3
DELAND CITY JAIL
DISCREET PROTECTIVE
ENCLOSURE FOR
DRUNK TANK AND ISOLATION
CELL
7-28-76

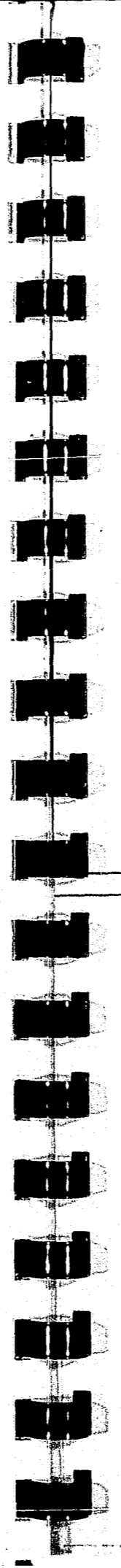

CONDUIT FROM CEILING

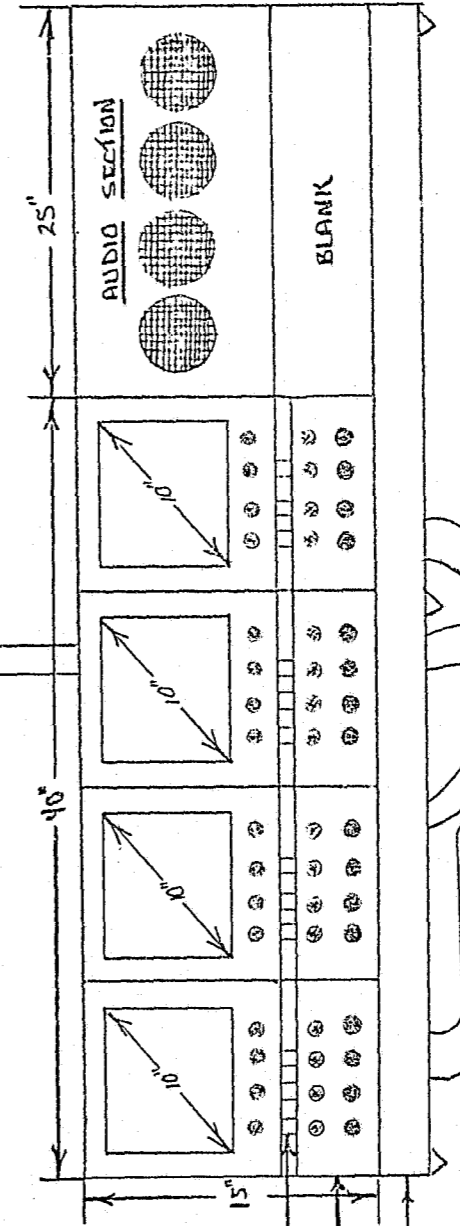

CAMERA LOCATION NAME PLATES

SEQUENTIAL SWITCHES

SHELF

40"

25"

15"

AUDIO SECTION

BLANK

BUSS PLUGS FOR MONITORS AND SEQUENTIAL SWITCHES AND OPTIONAL VCR

24 VAC TO CAMERAS

TRANSFORMER

COMMON 110/60

SK-4

PROPOSED EQUIPMENT LAYOUT AND RECOMMENDED ELECTRICAL DELAND CITY JAIL

END

7. 10/10/10