

ILECJ-STD-0305-00
JUNE 1975

LAW ENFORCEMENT STANDARDS PROGRAM

ACTIVE NIGHT VISION DEVICES

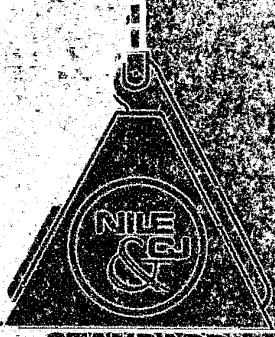

STANDARD

16291
e

U.S. DEPARTMENT OF JUSTICE
Law Enforcement Assistance Administration
National Institute of Law Enforcement and Criminal Justice

... 30 gr... a l... ..

... ..
... ..

... ..
... ..
... ..

LAW ENFORCEMENT STANDARDS PROGRAM

NILECJ STANDARD FOR ACTIVE NIGHT VISION DEVICES

**A Voluntary National Standard Promulgated by the
National Institute of Law Enforcement and Criminal Justice.**

JUNE 1975

**U.S. DEPARTMENT OF JUSTICE
Law Enforcement Assistance Administration
National Institute of Law Enforcement and Criminal Justice**

**LAW ENFORCEMENT ASSISTANCE
ADMINISTRATION**

Richard W. Velde, Administrator

**NATIONAL INSTITUTE OF LAW ENFORCEMENT
AND CRIMINAL JUSTICE**

Gerald M. Caplan, Director

ACKNOWLEDGEMENTS

This standard was formulated by the Law Enforcement Standards Laboratory of the National Bureau of Standards under the direction of Lawrence K. Eliason and Marshall A. Isler, Managers, Security Systems Program, and Jacob J. Diamond, Chief of LESL. Technical research was performed by Joseph C. Richmond of the Optical Radiation Section of the NBS Heat Division.

NILECJ STANDARD FOR ACTIVE NIGHT VISION DEVICES

CONTENTS

	Page
Foreword	v
1. Purpose	1
2. Scope	1
3. Definitions	1
4. Requirements	4
4.1 User Information	4
4.2 Workmanship	5
4.3 Marking	5
4.4 Size and Weight	5
4.5 Objective Lens Mounting	5
4.6 Battery Compartments	5
4.7 Controls	6
4.8 Tripod Socket	6
4.9 Eyepiece	6
4.10 Optical Gain	6
4.11 Optical Gain Stability	6
4.12 Light Equivalent Background	6
4.13 Light Induced Background	7
4.14 Luminance of Output Screen	7
4.15 Luminance Uniformity	7
4.16 Cathode and Screen Quality	7
4.17 Contrast Transfer Function	8
4.18 Viewer Distortion	8
4.19 Flare	8
4.20 Searchlight Alignment and Beam Spread	8
4.21 Effective Range	8
4.22 Transmission of Infrared Filter	8
4.23 Temperature and Humidity	8
5. Test Methods	8
5.1 Testing Schedule	8
5.2 Test Rooms	9
5.3 Test Equipment	10
5.4 Initial Inspection	12
5.5 Eyepiece Tests	13

	Page
5.6 General Test Procedures	13
5.7 Optical Gain Test	13
5.8 Filter Factor Measurement	15
5.9 Optical Gain Stability Test	15
5.10 Light Equivalent Background Test	15
5.11 Light Induced Background Test	15
5.12 Output Screen Luminance Test	16
5.13 Luminance Uniformity Test	17
5.14 Cathode and Screen Quality Test	17
5.15 Contrast Transfer Function Test	18
5.16 Distortion Test	20
5.17 Searchlight Alignment Test	22
5.18 Flare Test	22
5.19 Searchlight Beam Spread and Luminous Intensity Test	22
5.20 Effective Range	24
5.21 Filter Spectral Transmittance Measurement	24
5.22 High and Low Temperature Storage, Operation and Thermal Shock Tests ...	24
5.23 Humidity Test	24
Appendix A—Light Source	26
Appendix B—Scanning Device	28
Appendix C—Blackbody Cavity	29
Appendix D—Plane Source Spot	30
Appendix E—Large Size Resolution Chart Pattern Fabrication	31

FOREWORD

Following a Congressional mandate¹ to develop new and improved techniques, systems, and equipment to strengthen law enforcement and criminal justice, the National Institute of Law Enforcement and Criminal Justice (NILECJ) has established the Law Enforcement Standards Laboratory (LESL) at the National Bureau of Standards. LESL's function is to conduct research that will assist law enforcement and criminal justice agencies in the selection and procurement of quality equipment.

In response to priorities established by NILECJ, LESL is (1) subjecting existing equipment to laboratory testing and evaluation and (2) conducting research leading to the development of several series of documents, including national voluntary equipment standards, user guidelines, state-of-the-art surveys and other reports.

This document, NILECJ-STD-0305.00, Active Night Vision Devices, is a law enforcement equipment standard developed by LESL and approved and issued by NILECJ. Additional standards as well as other documents are being issued under the LESL program in the areas of protective equipment, communications equipment, security systems, weapons, emergency equipment, investigative aids, vehicles and clothing.

This equipment standard is a technical document consisting of performance and other requirements together with a description of test methods. Equipment which can meet these requirements is of superior quality and is suited to the needs of law enforcement agencies. Purchasing agents can use the test methods described in this standard to determine firsthand whether a particular equipment item meets the requirements of the standard, or they may have the tests conducted on their behalf by a qualified testing laboratory. Law enforcement personnel may also reference this standard in purchase documents and require that any equipment offered for purchase meet its requirements and that this compliance be either guaranteed by the vendor or attested to by an independent testing laboratory.

The necessarily technical nature of this NILECJ standard, and its special focus as a procurement aid, make it of limited use to those who seek general guidance concerning active night vision devices. The NILECJ Guidelines Series is designed to fill that need. We plan to issue guidelines to this as well as other law enforcement equipment as soon as possible, within the constraints of available funding and the overall NILECJ program.

The guideline documents to be issued are highly readable and tutorial in nature in contrast to the standards, which are highly technical, and intended for laboratory use by technical personnel. The guidelines will provide, in non-technical language, information for purchasing agents and other interested persons concerning the capabilities of equipment currently available. They may then select equipment appropriate to the performance required by their agency. Recommendations for the development of particular guidelines should be sent to us.

NILECJ standards are subjected to continuing review. Technical comments and recommended revisions are invited from all interested parties. Suggestions should be addressed

¹ Section 402(b) of the Omnibus Crime Control and Safe Streets Act of 1968, as amended.

to the Program Manager for Standards, National Institute of Law Enforcement and Criminal Justice, Law Enforcement Assistance Administration, U.S. Department of Justice, Washington, D.C. 20531.

Lester D. Shubin, Manager
Standards Program
National Institute of Law
Enforcement and Criminal Justice

NILECJ STANDARD FOR ACTIVE NIGHT VISION DEVICES

1. PURPOSE

The purpose of this document is to establish performance requirements and methods of test for active night vision devices used for law enforcement. It applies to devices which employ single-stage electrostatically focused image intensifier tubes having a maximum effective diameter of 25mm, a photocathode with S-1 sensitivity, and an infrared light source.

2. SCOPE

This document addresses portable active night vision equipment used primarily for handheld visual observation.

3. DEFINITIONS

3.1 Contrast Transfer Function

The ratio of the modulation contrast in the image of a square wave pattern to that in the pattern. Sometimes called square wave modulation transfer function.

3.2 Critical Focus

The focal position at which a lens or an optical system gives the sharpest image under a given set of conditions.

3.3 Distortion

Failure of an image to truly represent the shape of the object imaged, due to variation in magnification over the field of view.

3.4 Effective Range

The maximum distance from the object at which an active night vision device will produce a usable image.

3.5 Field Emission

An extraneous emission which appears as bright spots or patterns that flicker or appear intermittently in one general position on the phosphor screen of a night vision device. It is voltage dependent, and appears when there is no illumination on the photocathode.

3.6 Flare

Ghost images on the output screen of a night vision device produced by light from a bright source which is incident on the outer surface of the objective lens, and is specularly

reflected from the lens elements, diaphragm or barrel to form definite patterns in the image. The bright source causing flare may be inside or outside the field of view.

3.7 Group Number

The large numbers (1 through -4) that designate the groups of resolution patterns in the Air Force 1951 resolution chart (see figure 1).

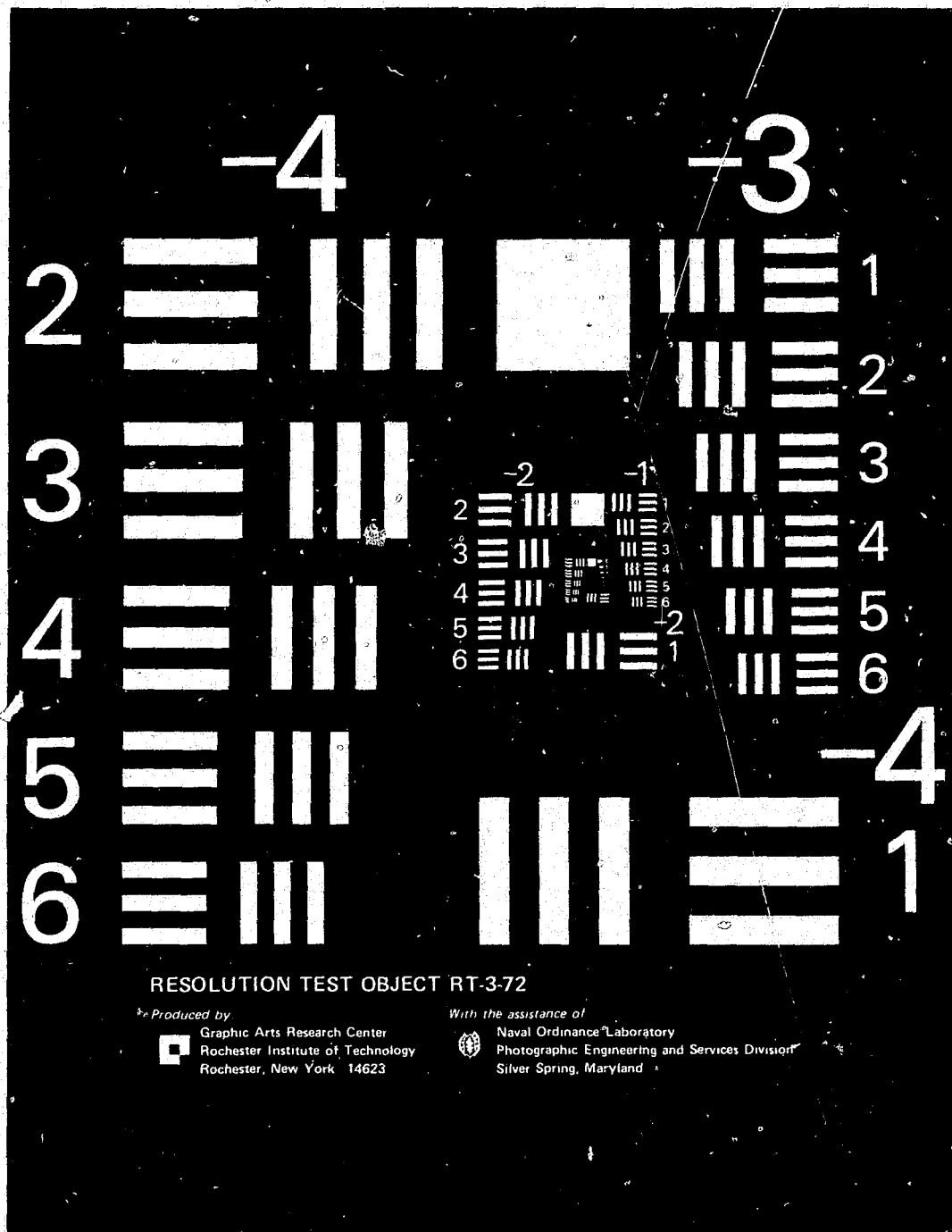

FIGURE 1. Resolution test chart used for contrast transfer function test.

3.8 Ion Spot

A bright diffuse area or spot near the center of the field of a night vision device. It increases in luminance as the photocathode illumination is increased, but may be swamped out at high photocathode illumination.

3.9 Light Equivalent Background

The luminance of a night vision device output screen when no light is incident on the input photocathode. This luminance is evaluated in terms of the luminance of a large-area uniform source, which, when viewed with the device, will produce an equivalent luminance in the absence of background. It is a measure of the dark current of the image intensifier tube.

3.10 Light Induced Background

The non-image-forming, more-or-less uniform background light from the surface of the output phosphor screen of a night vision device that is produced by light on the objective lens.

3.11 Luminance

Photometric brightness. The visual brightness of a surface, expressed as the luminous flux leaving the surface in a given direction per unit solid angle and per unit area projected normal to the given direction. The SI unit is the candela per square meter (cd/m^2).

3.12 Modulation Contrast

For a periodic pattern of a given spatial frequency, in which some optical property (such as luminance, illumination, radiance, irradiance, transmittance or reflectance) varies periodically, modulation contrast is the ratio of the difference between the maximum and minimum values of the property to their sum.

3.13 Modulation Transfer Function

A measure of the image quality of an imaging system or any part thereof, such as a lens, film, TV camera, etc., usually plotted as a function of the spatial frequency in the image. At any one spatial frequency, it is the ratio of the modulation contrast in the image to that in the object imaged, when the object luminance varies sinusoidally in one dimension.

3.14 Optical Gain

The ratio of the luminance of the output screen of a night vision device to the luminance of the source, when viewing a large area uniform diffuse source having the spectral distribution of CIE standard source A.¹

3.15 Optical Transfer Function

The spatial frequency response of an optical system. It consists of two parameters; one describes the variation of modulation with spatial frequency, and the other describes the phase shift (in the image) associated with that frequency. It is the Fourier transform of the line spread function.

3.16 Pattern Number

The number designation an individual pattern in a group in the Air Force 1951 resolution test chart. A pattern consists of two elements, each consisting of three lines and

¹ The spectral distribution of CIE Standard Source A is given in ASTM Standard Recommended Practice for Spectrophotometry and Description of Color in CIE 1931 System, E 308-66. The spectral distribution of Source A is indistinguishable from that of a blackbody at 2856K on the 1968 International Practical Temperature Scale, over the range of 350 to 1000 nm.

two spaces, one with the lines vertical, and the other with the lines horizontal. The spatial frequency, f , in line pairs per millimeter, of any pattern can be computed from the group number, G (any integer or zero), and pattern number, P (a positive integer from 1 to 6), as

$$f = 2^{[G+(P-1)/6]}$$

3.17 Relay Lens

A photographic lens designed for use at short viewing distances, and with near unity magnification. A relay lens is used to photograph the image on the output screen of a night vision device.

3.18 Searchlight

The light used with an active infrared night vision device. It is a lamp equipped with a fixed reflector and/or lens for focusing the light into a directional beam, and an infrared filter to absorb the visible light while passing the infrared light.

3.19 Viewer

A night vision device complete with objective lens, but without the searchlight. An "active night vision device" is a viewer with searchlight attached. A sectional drawing of a typical viewer is shown in figure 2.

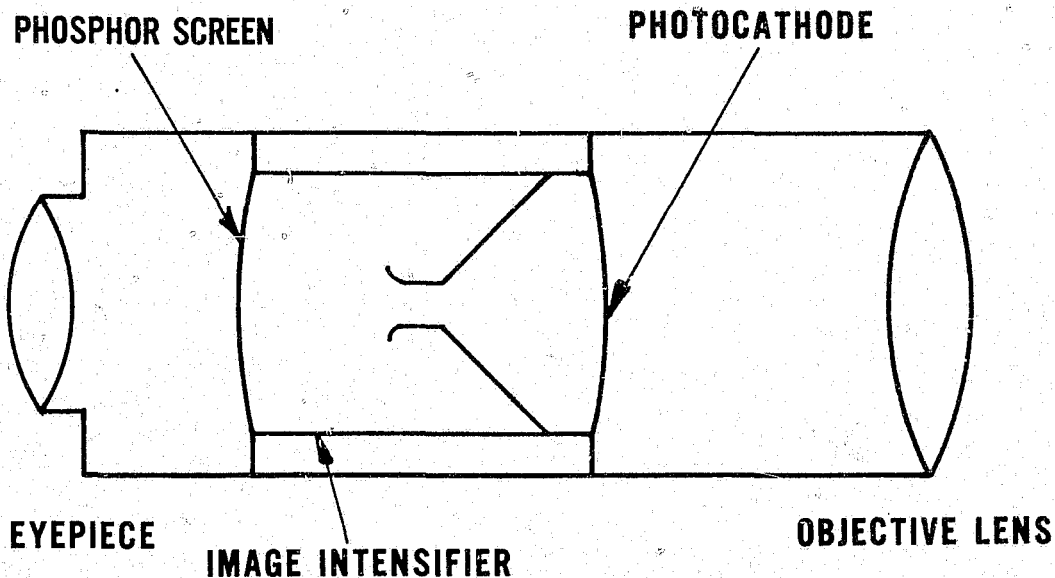

FIGURE 2. Schematic sectional drawing of a viewer.

4. REQUIREMENTS

4.1 User Information

The information supplied with the viewer by the manufacturer or distributor shall include:

- (a) Complete operating instructions, including details on eyepiece and objective lens focusing.
- (b) The focal length (in mm) and the f-number of the objective lens, and the T-number if available.
- (c) The magnification factor of the eyepiece lens.

- (d) Complete details on the thread used for mounting the eyepiece lens.
- (e) A complete identification or description of the objective lens mount.
- (f) Identification of the battery required for the viewer and a source of supply including catalog number.
- (g) Information on the use of a camera to photograph the image on the output screen of the viewer, including relay lens, and the camera mount if required.
- (h) A list of additional objective lenses available from the manufacturer.
- (i) A statement that commonly available photographic lenses can or cannot be used as objective lenses. A source of supply and catalog number for any required adapter, or an engineering drawing, shall be furnished.
- (j) Identification of the battery required for the searchlight, a source of supply, and a statement of its operating life, defined as the period of use during which a new and fully charged battery continues to provide a searchlight intensity of 50 percent or more of its initial value.
- (k) The searchlight beam spread, both vertical and horizontal. The edge of the beam shall be considered to be the point at which the beam intensity is 50 percent of its maximum value.
- (l) The effective range of the viewer with each combination of searchlight and objective lens that is supplied.

4.2 Workmanship

Workmanship shall be first class in every respect. All threads shall fit smoothly and firmly, with essentially no play. All exterior surfaces shall have a matte finish. All surfaces normally handled during use shall have a non-slip finish.

4.3 Marking

The night vision device shall be permanently and legibly labeled with the manufacturer's name, trade name of the device, if any, and model and serial numbers.

4.4 Size and Weight

The viewer, complete with monocular eyepiece, but without objective lens, shall not exceed 23 cm (9 in) in length, and its weight with the searchlight shall not exceed 4 kg (8.8 lb). For this purpose, the batteries shall be considered as part of the searchlight if the battery compartment is permanently attached to the searchlight; if a separate battery container is provided, connected to the viewer by an extension cord, only the cord shall be considered part of the searchlight.

4.5 Objective Lens Mounting

The objective lens mounting shall permit easy and rapid changing of lenses. The mount shall hold the lens in a fixed and reproducible position relative to the input photocathode of the night vision device, and shall lock in place preventing lens removal without intentional release. The focusing shall be smooth and positive. The full focal range from the nearest focal point to infinity shall be covered by no more than one complete revolution of the lens barrel, focusing knob, or focusing lever. The infinity stop shall be placed slightly beyond infinity (providing discernible defocusing) allowing movement beyond and return to the position of sharpest focus when focusing on distant objects.

4.6 Battery Compartments

The battery compartments for both the viewer and searchlight shall be clearly marked on the outside, or inside cover, with the type, voltage, and identifying number of the battery or batteries required. The proper polarity for inserting or connecting the batteries shall be clearly marked. If the device can be damaged by insertion of batteries in reverse

polarity, the contacts shall be of such design that electrical contact is not made if batteries are inserted with reverse polarity.

4.7 Controls

All switches and control settings shall be identified as to function by clear markings that are visible in dim light. The power switch shall be provided with a guard, to minimize the possibility of the switch being turned on accidentally.

4.8 Tripod Socket

The night vision device shall be equipped with one or more metal tripod sockets ($\frac{1}{4}$ —20 thread) in conformance with USASI Standard PH 3.6—1952, Reaffirmed 1963.² Threaded plastic is unacceptable. The depth of the threaded portion of the hole shall be not less than 5 mm (0.2 in) when fabricated of brass or steel, and not less than 7.5 mm (0.3 in) when fabricated of aluminum or other soft metal. The axis of the tripod socket(s) shall be normal to the optical axis of the viewer and lie in the vertical plane through it. There shall be a socket located so that its axis passes near the center of gravity of the viewer for any combination of objective lens, eyepiece, and camera and adapter. When tested in accordance with paragraph 5.5, the torque required to maintain the viewer in a horizontal plane shall not exceed 1.10 newton-meter (9.7 lbf-in).

Accessories (lens, eyepiece, or camera with adapter) shall be supplied with a combination support/mounting plate if the torque required to maintain the resulting assembly in a horizontal plane exceeds 1.10 newton-meter (9.7 lbf-in). The support/mounting plate shall have one or more tripod sockets meeting all requirements of this paragraph.

4.9 Eyepiece

4.9.1 Radiation

When measured in accordance with paragraph 5.5.1, the eyepiece radiation count shall not exceed twice the background radiation count.

4.9.2 Focus Adjustment

When tested in accordance with paragraph 5.5.2, the eyepiece focus shall be adjustable over a range of at least 8 diopters, have a minimum positive adjustment of 2.0 diopters and a minimum negative adjustment of 4.0 diopters, and the adjusting torque shall not exceed 0.80 newton-meter (7.1 lbf-in).

4.9.3 Curvature of Field

When measured in accordance with paragraph 5.5.3, the curvature of field of the eyepiece lens shall be not more than one half of its depth of focus, when focused at infinity.

4.9.4 Distortion

When tested in accordance with paragraph 5.5.4, the eyepiece lens shall have zero positive distortion, and not more than 10 percent negative distortion.

4.10 Optical Gain

When measured in accordance with paragraph 5.7, the optical gain of the viewer shall be 0.30 or more.

4.11 Optical Gain Stability

When evaluated in accordance with paragraph 5.9, the optical gain shall not change by more than 5 percent per hour.

4.12 Light Equivalent Background

When evaluated in accordance with paragraph 5.10, the light equivalent background shall not exceed 0.002 cd/m².

² Available from the American National Standards Institute, 1430 Broadway, New York, N. Y. 10018.

4.13 Light Induced Background

When evaluated in accordance with paragraph 5.11, the light induced background of the viewer shall not exceed 0.35.

4.14 Luminance of Output Screen

When measured in accordance with paragraph 5.12, the luminance of the output screen shall not exceed 2500 cd/m². There shall be provision for limiting the luminance of the output screen to 500 cd/m², for use under dark adapted conditions. A red filter may be used for this purpose.

4.15 Luminance Uniformity

When measured in accordance with paragraph 5.13, the luminance of the output screen shall not fall outside the tolerance limits shown in figure 3 over the circular area centered on the optic axis of the screen and having a diameter of 80 percent of that of the output screen.

4.16 Cathode and Screen Quality

When the output face of the screen is examined in accordance with paragraph 5.14, with the objective lens capped, it shall show no ion spots, field emission, leakage or faceplate breakdown. When the device is viewing a source of uniform luminance, the light and dark spots with contrast greater than ± 30 percent relative to the surrounding area shall not exceed the numbers listed in table 1 for 18 mm diameter tubes, or in table 2 for 25 mm diameter tubes.

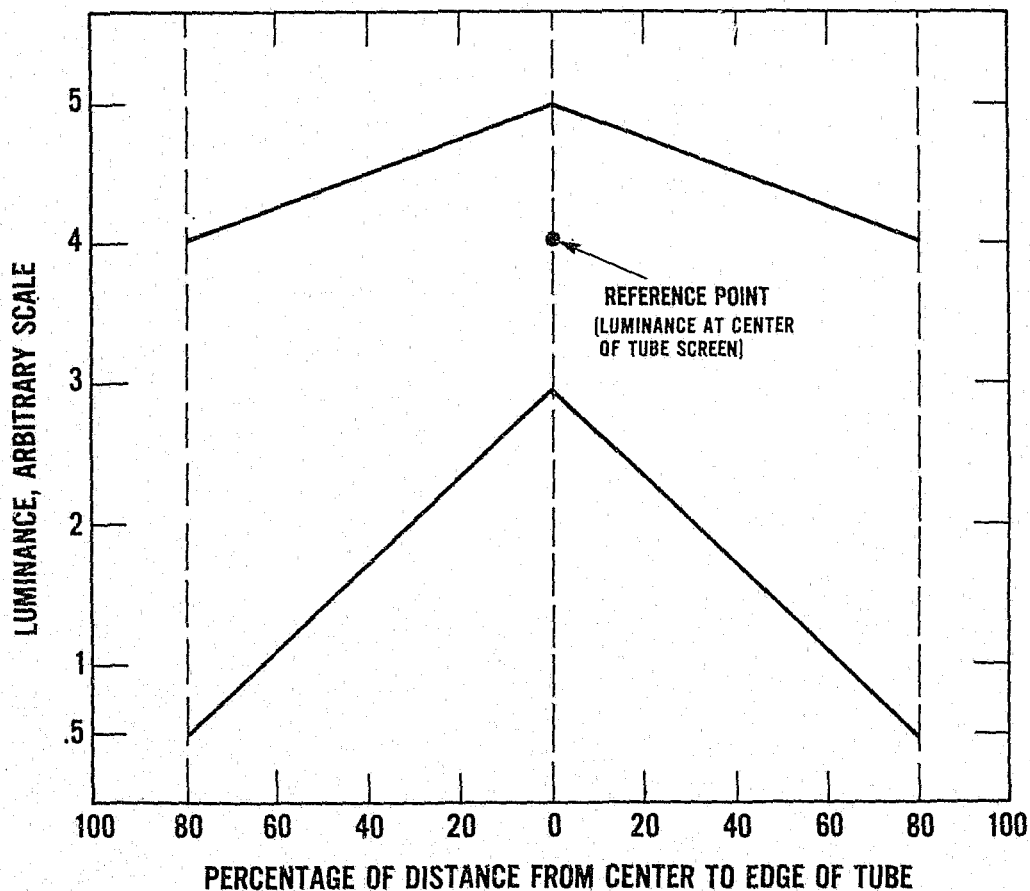

FIGURE 3. Luminance uniformity requirement.

4.17 Contrast Transfer Function

When evaluated in accordance with paragraph 5.15, the contrast transfer functions at the respective spatial frequencies shall be not less than the values given below. Modulation transfer functions (MTF) may be used instead of contrast transfer functions (CTF).

<i>Spatial Frequency</i> (Line Pairs per mm)	<i>CTF (MTF)</i>
2.5	0.90
7.5	0.75
16.0	0.35
22.0	0.20

4.18 Viewer Distortion

When measured in accordance with paragraph 5.16, the distortion shall be 10 percent or less.

4.19 Flare

When measured in accordance with paragraph 5.18, the flare rating of the viewer shall be 0 (i.e., no measurable flare).

4.20 Searchlight Alignment and Beam Spread

When measured in accordance with paragraph 5.17, the axis of the searchlight beam shall be aligned with the optional axis of the viewer to within 10°, and when tested in accordance with paragraph 5.19, the beam spread of the searchlight shall not exceed that specified by the manufacturer.

4.21 Effective Range

When calculated in accordance with paragraph 5.20, the effective range of the active night vision device shall equal or exceed that stated by the manufacturer. The filter factor required for this calculation shall be determined in accordance with paragraph 5.8.

4.22 Transmission of Infrared Filter

When measured in accordance with paragraph 5.21, the infrared filter shall have the special transmittance distribution shown in figure 4, and a spectral transmittance at 800 nm of not more than 0.00075, Kopp³ No. 1210 and Corning⁴ No. 2540 glasses are satisfactory.

4.23 Temperature and Humidity

When subjected to the high and low temperature storage, operation and thermal shock tests in accordance with paragraph 5.22, and the humidity test in accordance with paragraph 5.23, the viewer (complete with objective lens, eyepiece, and batteries) shall show no resultant loosening, breakage or corrosion of any finish, optical coating, connection or component, no condensation of moisture within the optical system, no high voltage breakdown, and no failure to operate.

5. TEST METHODS

5.1 Testing Schedule

The testing sequence shall follow the numerical order of test method presentation within this standard.

³ Kopp Glass Inc., P. O. Box 8255, Swissvale, PA.

⁴ Corning Glass Works, Corning, N.Y. 14830.

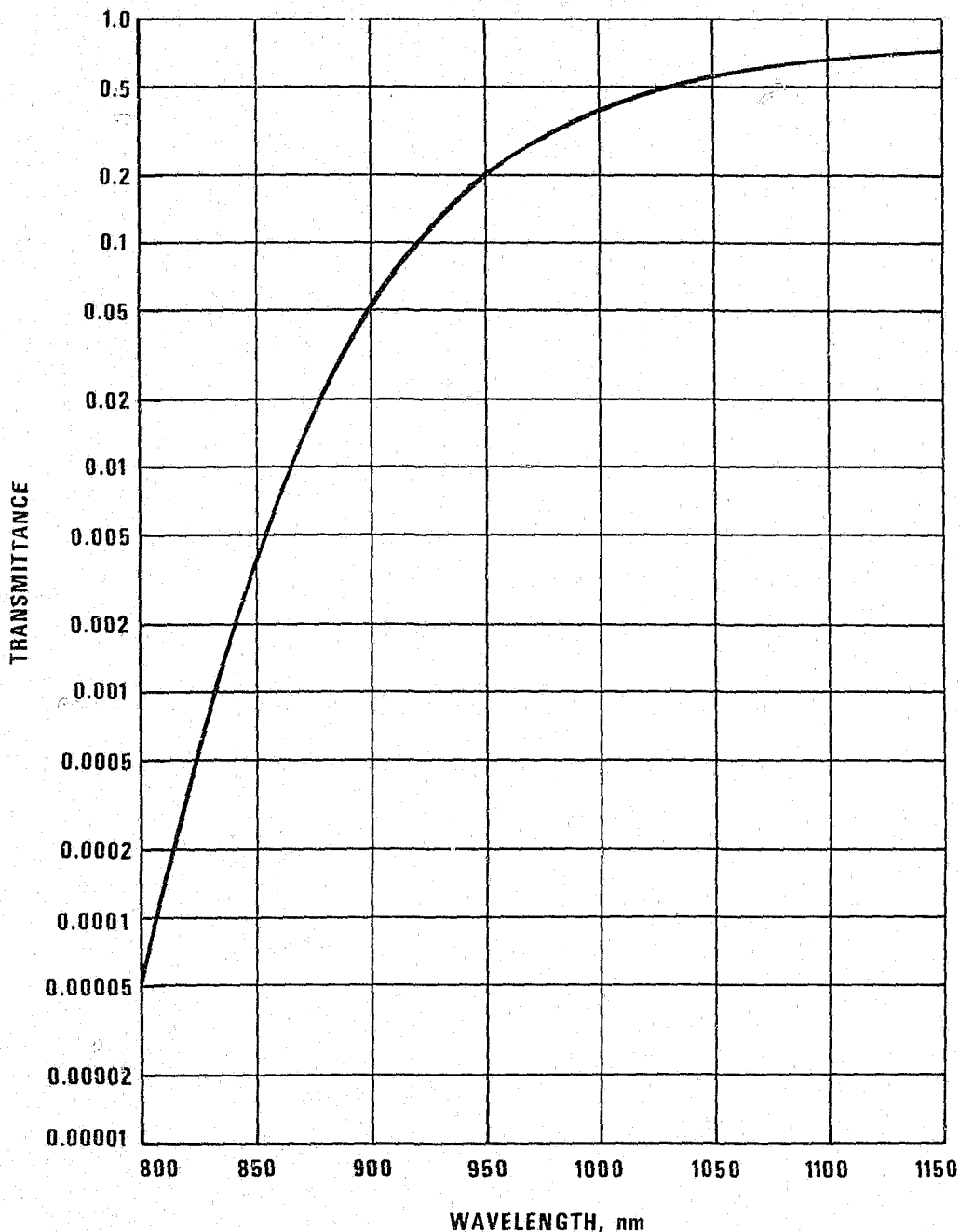

FIGURE 4. Spectral distribution curve of transmittance of infrared filter.

Tests for optical gain, output screen luminance, contrast transfer function, flare, temperature and humidity shall be repeated using each objective lens supplied with the viewer. All other viewer optical tests shall be performed one time, using any of the objective lenses supplied with the viewer.

5.2 Test Rooms

Optical tests must be performed in laboratories in which the luminance of any light source or leak does not exceed 1×10^{-6} cd/m². The luminance of a sheet of white paper placed in any area viewed by the photometer during a test shall not exceed 1×10^{-9} cd/m², with all lights off. Precautions must be taken to shield pilot lights on telephones and equipment, and electronic tubes, so that no stray light escapes.

A minimum room size of 3.2×7.3 m (9.8×22.2 ft) is required for all tests except distortion and flare, which require a minimum size of 2.5 m by 20 m (7.6×61 ft). The length of the latter room must be at least 8 m plus 133 times the focal length of the longest focal length objective lens on a device to be tested. A minimum room height of 2.5 m (7.6 ft) is required.

5.3 Test Equipment

5.3.1 Variable Luminance Light Source

The light source shall have the spectral distribution of CIE Standard Source A,² be completely diffuse, be uniform in luminance to within 2 percent over its entire area, and be capable of being varied over the range of 0.01 to 100 cd/m². For the light induced background test, the source shall be large enough to fill the entire field of view of the viewer being tested, at a distance of 1 m. When measuring luminance uniformity, the aperture of the source must be larger than the effective diameter of the objective lens of the device plus the diameter of the image intensifier tube. For all other tests, the source aperture must be larger than the effective diameter of the objective lens on the device to be tested. A source meeting these requirements is described in appendix A. A large area plane illumination source is satisfactory, but difficult to design in accordance with the above requirements.

5.3.2 Photometer

The photometer shall measure luminance over the range of approximately 5×10^{-5} to 500 cd/m². The photometer must have at least three objective lenses: one of long focal length, approximately 180 mm; one of intermediate focal length, providing 1 to 1 magnification at a viewing distance of approximately 10 cm; and a microscope objective having 10 \times magnification, for use as a microphotometer.

The photometer shall have six apertures located in the objective lens image plane, five circular and one in the form of a rectangular slit. The circular apertures shall subtend conical angles of view having included plane angles of approximately 2, 6 and 20 minutes, and 1 and 3 degrees, and fields of view, when used with the 1 \times magnification lens, having diameters of approximately 0.1, 0.3, 1.0, 3.0 and 10.0 mm. The slit aperture shall have a length ten times its width and when used with the 10 \times magnification lens, the field viewed by the slit shall be no larger than 5 by 50 μ m.

The size of the various apertures may vary by as much as 20 percent from these requirements, but the actual size shall be known to at least 1 percent.

The photometer shall provide both a digital display, reading in cd/m², and an analog voltage proportional to the digital display. When properly calibrated, by use of a large-area source of known luminance, the photometer error shall not exceed 5 percent, and the repeatability over a period of 1 hour shall be within 1 percent over the entire range.⁵ The photometer shall be equipped with a removable baffle to convert it to an illumination meter for small sources.

Two sources of photometers which meet these requirements have been identified. A suitable photometer can be assembled from modular components manufactured by Gamma Scientific, Inc., 3777 Ruffin Road, San Diego, California 92123. The Spectra-Pritchard model 1980 with 25×250 μ m slit aperture option and CDB control console, manufactured by the Photo Research Division of Kollmorgen Corp., 300 North Hollywood Way, Burbank, California 91550, is also suitable.

5.3.3 Automatic Scanning Device

A linear motion device is required to move the resolution chart vertically in front of

⁵ Boris Merik, Light and Color Measurements of Small Light Sources, pp. 70-71. General Electric Company (1968).

the aperture of the light source during the contrast transfer function test, and to move the viewer vertically during the luminance uniformity test. The linear motion device shall have constant vertical speeds in the range of 1 to 15 mm/min, and be capable of driving a load of 10 kg (22 lbs) with essentially no angular movement of the load while moving. A suitable device is described in appendix B.

5.3.4 Black Spot

A blackbody cavity, with an aperture at least 1.75 cm in diameter, is required for use with the integrating sphere source to produce the black spot for the light induced background test. The diffuse-normal reflectance of the cavity aperture shall not exceed 0.1 percent. A cavity meeting these requirements is described in appendix C.

The use of a large area plane illumination source for the light induced background test requires an opaque black dot attached to the front of the source. A suitable black dot is described in appendix D.

5.3.5 Adjustable Testing Mounts

One adjustable mount shall provide horizontal adjustment in directions parallel and normal to the optical axis and shall have an adjustable stop for the motion normal to the optic axis, so the viewer can be moved out of the line of sight of the photometer and later returned to its original position. A second adjustable mount, for the photometer, shall provide micrometer adjustment in a horizontal plane parallel and normal to its line of sight, and in a vertical direction normal to the line of sight. A goniometer mount is required for use in measuring the searchlight beam spread. It shall provide adjustment of at least 60° in both elevation and azimuth, and shall measure angles to an accuracy of 0.5°.

5.3.6 Test Charts

Three test charts are required: two resolution charts of the Air Force 1951 design (a negative transparency and a positive reflection resolution test chart, figure 1); and a distortion chart. Both resolution test charts are available from the Graphic Arts Research Center, Rochester Institute of Technology, Rochester, New York 14623. The negative transparency is identified as Resolution Test Object, TR-3-72, and the positive reflection chart as Large Scale Test Object, Water Resistant. For use, the reflection chart must be cemented to a rigid plane backing, such as plywood.

The distortion chart (figure 5) is 1.8 m square, plane to within about 6 mm, painted white and consists of a square grid of black lines, 3 mm wide on 10 cm centers. A center square with sides at 45° to the grid axis is formed by diagonals of the four squares whose corners meet at the center. The chart is attached to a mount that can be adjusted for tilt about vertical and horizontal lines, and provision for mounting a first-surface mirror at the center of the chart with its surface parallel to that of the chart is required.

5.3.7 Flare-Light Sources

Three flare-light sources are required, each providing a conical beam having an included plane angle of 5°. A sketch of a suitable flare-light source is shown in figure 6.

5.3.8 Environmental Test Chambers

Two environmental test chambers are required; one which can maintain temperatures in the range from 22 to 50°C (72 to 122°F) with temperature control to $\pm 1^\circ\text{C}$ ($\pm 1.8^\circ\text{F}$) and maintain relative humidity between 90 and 98 percent and, another which can provide temperatures from 22 to -25°C (72 to -13°F) with temperature control to $\pm 1^\circ\text{C}$ (1.8°F). The working volume of each chamber shall be not less than $30 \times 30 \times 45$ cm ($1 \times 1 \times 1.5$ ft). Recorders shall be provided to continuously record temperature and humidity during a test.

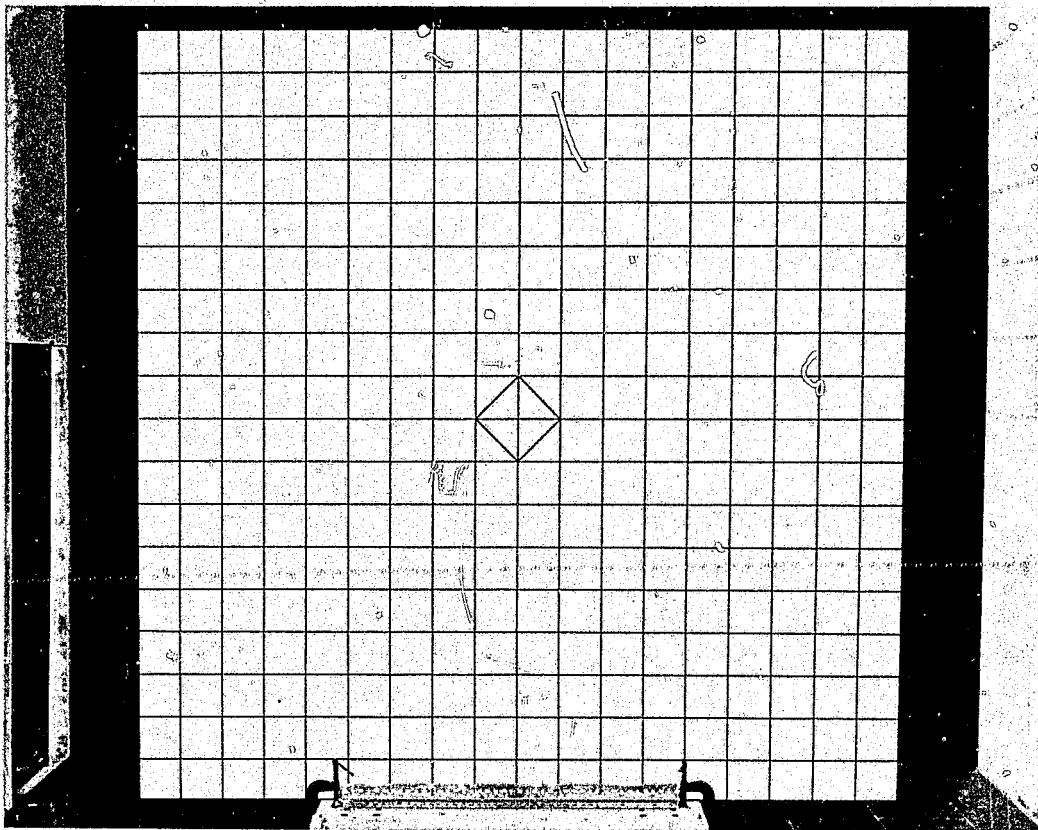

FIGURE 5. Distortion test chart.

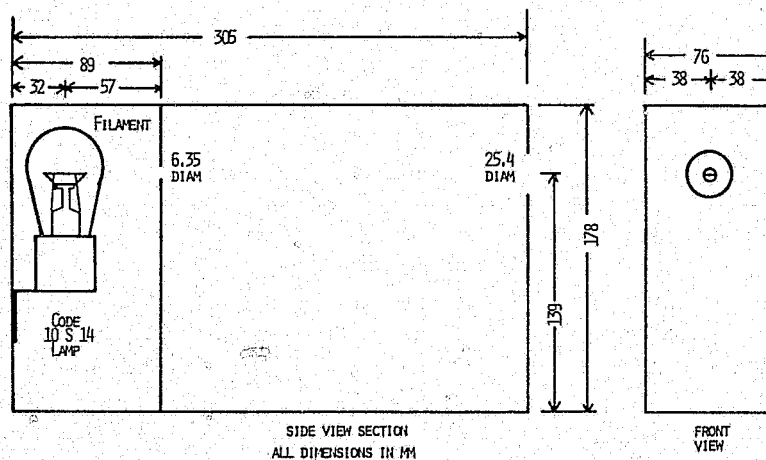

FIGURE 6. Cross sectional view of flare-light source.

5.4 Initial Inspection

Examine the night vision device to determine compliance with paragraphs 4.2 through 4.8.

Mount the viewer on a tripod, free to rotate in a vertical plane only, and measure the vertical force necessary to maintain the viewer in a horizontal plane, using a spring balance. Compute the torque required to maintain this position from the measured vertical force and horizontal distance from the point of measurement to the vertical plane through the horizontal axis of rotation.

Repeat the above inspection and measurement for each viewer lens and accessory combination, and for each mounting/support plate furnished with the viewer.

5.5 Eyepiece Tests

5.5.1 Radiation

Place the viewer eyepiece in a shielded container with the surface normally closest to the eye adjacent to the alpha radiation counter. Count the radioactive particles detected for a period of 5 minutes. Remove the eyepiece from the shielded container and count the background for 5 minutes. Divide the eyepiece radiation count by the background radiation count.

5.5.2 Focus

Place the eyepiece in a temporary mount and adjust it to the approximate center of its adjustable range, with a target 13 mm in front of it. Place a diopter tester against the eyepiece and adjust the tester for clear focus of the target as seen through the eyepiece and diopter tester. Record the reading on the diopter tester. Adjust the eyepiece to both extreme settings, and record the reading on the diopter tester for clear focus at each position.

Rotate the eyepiece lens using a torque wrench and adapter, first clockwise and then counterclockwise, and observe the reading on the torque wrench in each case.

5.5.3 Curvature of Field

Test the eyepiece lens for curvature of field by method 17, paragraph 5.1.2.13.2, focal length by method 2, paragraph 5.1.2.2.2, and aperture ratio (f-number) by the method described in paragraph 5.1.2.8, all of MIL-STD-150A,⁶ June 8, 1961. Compute the depth of focus in mm as $0.04N$ where N is the aperture ratio of the eyepiece lens.

5.5.4 Distortion

Measure the distortion of the eyepiece lens by method 28, paragraph 5.1.2.16.4 of MIL-STD-150A, June 8, 1961.

5.6 General Test Procedures

Perform all optical tests of night vision devices with the viewer equipped with fully-charged batteries—total period of prior use not to exceed four hours. Allow the viewer to stabilize for a minimum of five minutes after it is turned on before performing any tests.

Allow the photometer to stabilize for a minimum of ½ hour after it is turned on before making any measurements. Prior to use, calibrate the photometer against the internal source and adjust the zero and dark currents.

Permit the light source to stabilize for a minimum of 5 minutes after any lamp is turned on.

5.7 Optical Gain Test

5.7.1 Calibration of Photometer Lens

Adjust the light source to a luminance of 0.01 cd/m^2 and position the photometer 40 cm from and normal to the source. Measure and record the luminance using the 180 mm lens and 1° aperture. Move the photometer forward, to 15 cm from the source, and measure and record the luminance using the 90 mm lens and 1° aperture. Calculate the correction factor C as

$$C = (180 \text{ mm lens reading}) / (90 \text{ mm lens reading}).$$

Repeat this measurement a minimum of 10 times until a standard deviation of less than 0.005 is obtained for the mean of C . Check the correction factor at intervals of 4 to 6

⁶ Available from Naval Publications and Forms Center, 5801 Tabor Avenue, Philadelphia, Pa. 19120.

weeks, unless one of the lenses is cleaned, which requires that a new correction factor be established.

5.7.2 Measurement of Optical Gain

Place the viewer on an adjustable mount, positioned against a lateral movement stop, immediately in front of the light source, with the viewer axis centered on and normal to the aperture. Focus the viewer on the source and remove the eyepiece. Position the photometer, on an adjustable mount, 17 cm behind the viewer output screen, aligned with the viewer axis as shown in figure 7. Adjust the source luminance to 0.90 cd/m².

Focus the photometer on the viewer output screen using the 90 mm objective lens and 1° aperture, measure the luminance and record the value. Note and record the time of measurement. Move the viewer out of the photometer line of sight, replace the 90 mm objective lens with the 180 mm lens and, still using the 1° aperture, focus on the source. Measure and record the luminance.

Measure the viewer screen and source luminances at 10 values of source luminance from 0.01 to 100 cd/m² varying by a factor of about 4 between successive values, and again at 0.90 cd/m². Record the time of the last measurement.

Compute the optical gain, G, for each source luminance level as:

$$G = \frac{\text{Screen Luminance}}{\text{Source Luminance}} \times C$$

Plot the optical gain, G, as a function of the logarithm of the source luminance to produce the optical gain curve of the viewer (semi-log paper is convenient). The maximum optical gain in the range of source luminance from 0.01 to 100 cd/m² is the optical gain of the viewer.

Measurement of the optical gain of a viewer with an objective lens of known focal length F in m, T-number T and f-number f permits the calculation of the optical gain of the viewer when used with any other objective lens for which the same parameters are known.

Compute the transmittance, τ , for each lens as

$$\tau = f^2/T^2$$

Compute the magnification, M, for each lens as

$$M = F/(D-F)$$

where D is the distance from the object to the lens, which may be taken as 50 m.

Compute the optical gain, G, of the viewer with lens 2 from the measured optical gain, G₁, with lens 1, by use of the following equation, where the subscripts indicate the parameters of lenses 1 and 2 respectively.

$$G = \frac{G_1 \cdot \tau_2 [(2f_1)^2 \cdot (M_1 + 1)^2 + 1]}{\tau_1 [(2f_2)^2 \cdot (M_2 + 1)^2 + 1]}$$

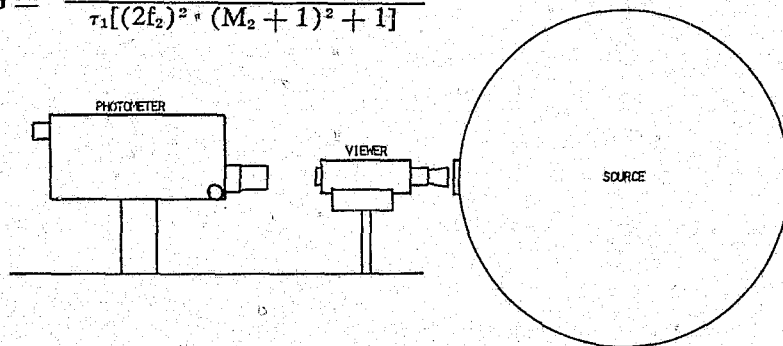

FIGURE 7. Equipment arrangement for optical gain, light equivalent background, and cathode and screen quality tests.

5.8 Filter Factor Measurement

Following the optical gain test, remove the infrared filter from the searchlight and place it between the viewer and the light source. Increase the luminance of the light source to 60 ± 15 cd/m², measure the luminance of the output screen and compute the gain of the filter-viewer combination. Remove the filter and reduce the luminance of the light source until the luminance of the output screen of the viewer is approximately the same as with the filter in place. Measure the light source luminance and compute the gain of the viewer at this light level. The ratio of the gain of the viewer with the filter to the gain without the filter is the filter factor, τ_f .

5.9 Optical Gain Stability Test

The percentage change in optical gain per hour of operation, ΔG , is computed from the optical gain, G_B , measured at a source luminance of 0.90 cd/m² at the beginning of the optical gain test, the optical gain G_E , measured under the same conditions at the end of the optical gain test, and the elapsed time, Δt , in hours between the two tests, Δt not to exceed 2 hours.

$$\Delta G = \frac{G_B - G_E}{G_B} \times \Delta t \times 100$$

5.10 Light Equivalent Background Test

Following completion of the optical gain test, cap the objective lens of the viewer and measure the luminance of its output screen as L_o . Compute the light equivalent background, L.E.B., as

$$\text{L.E.B.} = L_o / G_o$$

where G_o is the optical gain, measured at the lowest value of luminance of the source, approximately 0.01 cd/m².

5.11 Light Induced Background Test

The photometer calibration requires a small black dot target. Cut a 0.5 mm (0.020 in) diameter dot from brass shim stock, blacken it with india ink, and mount it on a piece of flashed opal glass on the side opposite the flash. Place this target in a vertical position on a translation stage providing horizontal and vertical motion in the plane of the glass and illuminate it from the rear with a frosted 40 watt light bulb, 17 cm from the glass, shielded with a 5 cm diameter tube blackened on the inside, as shown in figure 8. Mount the photometer, using the 90 mm objective lens, on an adjustable stage providing motion parallel and normal to its line of sight in the horizontal plane. Center the dot in the photometer field of view, focus upon the dot, bring the 6' aperture into the field of view, and center it on the dot. Adjust the photometer focus until the measured luminance is at its minimum. Measure and record the luminance of the dot L_D . Move the glass until the aperture appears to be separated from the dot by approximately the diameter of the dot, measure and record the luminance of the light area L_L . Compute the veiling glare V.G. of the photometer as

$$\text{V.G.} = L_D / L_L$$

Place the viewer on an adjustable mount, positioned against a lateral movement stop, immediately in front of the light source, with the viewer axis centered on the aperture and normal to it. Position the photometer, in an adjustable mount, 17 cm behind the viewer output screen, aligned with the viewer axis. Remove the plug in the back wall of the light

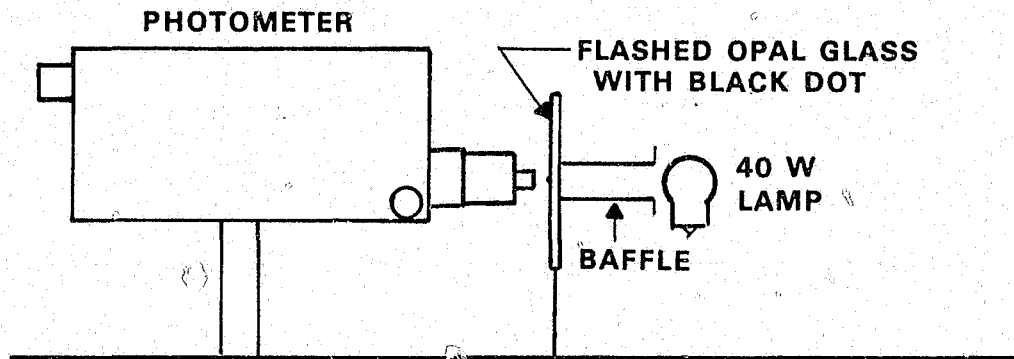

FIGURE 8. Equipment arrangement for measuring veiling glare of photometer.

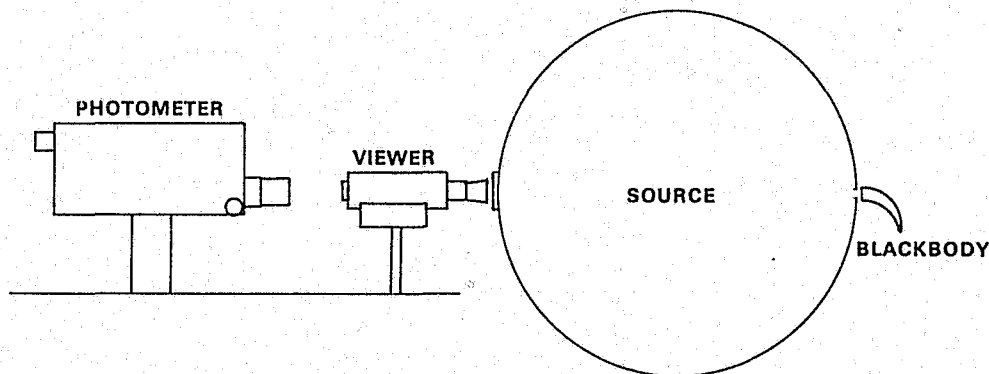

FIGURE 9. Equipment arrangement for light induced background test.

source sphere and place the black body behind and centered on the hole (figure 9). Focus the viewer on the hole, then remove the eyepiece, and focus the photometer on the output screen, using the 90 mm objective lens. Adjust the viewer to center the image of the hole on the screen. (If the screen has an etched reticle, the image should be near the center but must not be on the reticle lines). Bring the photometer aperture nearest the size of the image (bigger or smaller) into the field of view and center it on the image. Adjust the viewer objective lens, focusing to achieve minimum luminance as measured by the photometer, and then adjust the photometer focus until the measured luminance, is minimum. Bring an aperture $\frac{1}{3}$ to $\frac{2}{3}$ the size of the hole image into the field of view, center it on the image, measure the luminance L_B of the image and record. Move the photometer horizontally until the aperture is separated from the hole image by the diameter of the hole imaged, measure the luminance of the light background L_L , and record. Measure L_B and L_L at 10 levels of source luminance covering the range from 0.01 to 10 cd/m^2 .

Compute the light induced background, L.I.B., for each level of source luminance as

$$\text{L.I.B.} = (L_B/L_L) - \text{V.G.}$$

The maximum value measured in the range of .01 to 10 cd/m^2 is the light induced background of the viewer.

5.12 Output Screen Luminance Test

The highest value of screen luminance, determined in the test for optical gain (paragraph 5.7) times the calibration factor C (paragraph 5.7) is the luminance of the output screen.

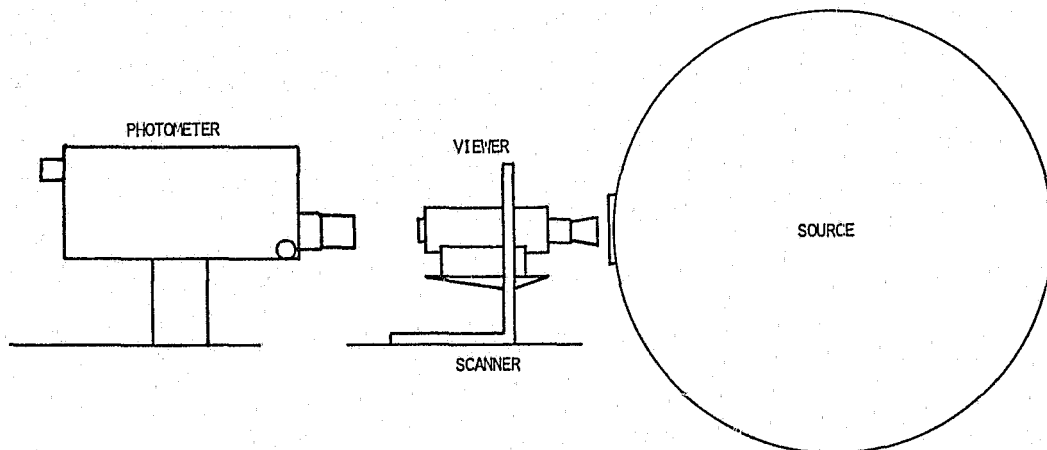

FIGURE 10. *Equipment arrangement for luminance uniformity test.*

5.13 Luminance Uniformity Test

Mount the viewer on the automatic scanning device, with the objective lens 1 cm from and normal to the source aperture and with the eyepiece removed, as shown in figure 10. Mount the photometer, using the 90 mm objective lens and 20' aperture, 20 cm behind the viewer, aligned with the viewer axis and focus on the output screen. Connect the scanner potentiometer to the x axis of an x-y recorder and the photometer analog output to the y axis. Adjust the source luminance to approximately 10 cd/m². Center the photometer on the output screen, check the zero on the y axis, and adjust the photometer and y axis recorder span to between 60 and 80 percent of full scale.

Manually scan the viewer upward until the photometer aperture is just below the image of the viewer output screen. Set the scanner potentiometer to zero, adjust the recorder x-axis to zero, and adjust the span to nearly full scale for a viewer movement of slightly more than the screen diameter. Scan the viewer downward automatically along the vertical diameter of the viewer at a speed of about 2 mm/min until the image is below the photometer aperture.

Normalize the recorded viewer output screen luminance to a y-value of 4.0 at the center of the screen and x-values of 100 at the points where the curve falls to zero. Draw the limits on the normalized curve as shown in figure 2.

5.14 Cathode and Screen Quality Test

Position the viewer with eyepiece removed in front of the source aperture as in figure 6. Cap the viewer lens and examine the phosphor screen for ion spots and field emission in a dark room. Use a low power microscope (3 to 5x magnification) or the photometer with 90 mm objective lens and low magnification (3.3x). Remove the cap and turn on the source at a luminance of approximately 0.1 cd/m². Gradually increase the luminance while examining the screen until a luminance of 70 cd/m² is reached. Reduce the luminance to 1.0 cd/m² and examine the screen for dark and light spots with contrast of more than 30 percent relative to the background. Count the spots in the different areas as listed in tables 1 or 2. A spot with half or twice the luminance of the background will have a contrast of 33 percent, and is readily visible. If in doubt, measure with the photometer and compute the contrast. Measure the spot sizes using a microscope with reticle scale or estimate by comparison with the photometer apertures.

TABLE 1. Cathode and Screen Spots for 18 mm Tubes

Largest Dimension of Spots mm	Number of Spots in Circles of Indicated Diameter		
	Inside 5.6 mm	Outside 5.6 mm Inside 14.7 mm	Outside 14.7 mm Inside 17.8 mm
≥ 0.38	0	0	0
0.3 to < 0.38	0	1	2
0.23 to < 0.3	0	3	8
0.15 to < 0.23	0	9	18
0.076 to < 0.15	3	30	40
0.025 to < 0.076	10	35	—

TABLE 2. Cathode and Screen Spots for 25 mm Tubes

Largest Dimension of Spots mm	Number of Spots in Circles of Indicated Diameter		
	Inside 7.6 mm	Outside 7.6 mm Inside 20 mm	Outside 20 mm Inside 24.8 mm
≥ 0.38	0	0	0
0.3 to < 0.38	0	1	2
0.23 to < 0.3	0	3	8
0.15 to < 0.23	0	12	26
0.076 to < 0.15	3	40	—
0.025 to < 0.76	15	—	—

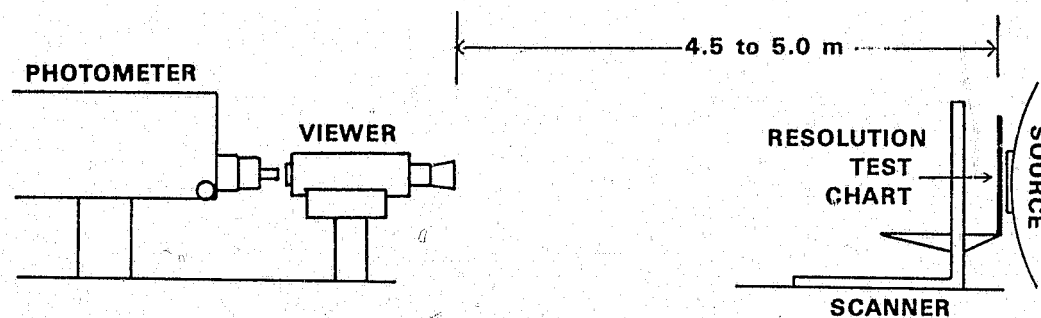

FIGURE 11. Equipment arrangement for contrast transfer function test.

5.15 Contrast Transfer Function Test

Mount the negative transparency resolution chart on the automatic scanner, one centimeter in front of and parallel to the plane of the light source aperture (see figure 11). Position the viewer 4.5 to 5 m from the source aperture, with its optical axis aligned normal to and centered on it when against the horizontal translation stop. Critically focus the viewer on the resolution chart with the source on. Remove the eyepiece and measure the distance D , in meters, from the outer surface of the viewer objective lens to the chart, to the nearest centimeter.

Position the photometer, with its 10× microscope objective, 1 cm behind the viewer, aligned with the viewer axis. Move the viewer out of the line of sight of the photometer, install the 180 mm objective lens and focus on the target using the 6' aperture. Connect the photometer analog output to the y-axis of an x-y recorder, and the output of the potentiometer on the scanning device to the x-axis.

Adjust the source luminance to 30 cd/m² as measured on the large light square near the center at the top of the chart (figure 1). Replace the 180 mm objective with the 10× objective, move the viewer back in front of the photometer, and focus the photometer upon the output screen. The phosphor grains can be clearly seen when the photometer is properly focused. Bring the slit aperture into the photometer field of view, and adjust the photometer to view an area within 2 mm of the center of the output screen, being careful to see that the slit does not fall on the image of the etched reticle, if present. Manually drive the chart to center the groups -2 to +1 in the source aperture. Manually adjust the chart until the slit aperture is well centered on a bright line whose image is about the same width as the slit. Adjust the position of the chart until the photometer reading is at its maximum. Focus the viewer objective lens for the maximum photometer reading, then focus the photometer to again obtain the maximum reading. Repeat the entire process at least once to be sure critical focus of both viewer objective lens and photometer has been attained. The measured CTF can be significantly degraded by slight deviations from critical focus.

With the photometer shutter set on zero, adjust the photometer dark current and zero controls to give a true zero. Adjust the recorder to read zero on the y-axis. Open the photometer shutter, and manually drive the chart to center the image of the large light square about the slit aperture. Adjust the potentiometer sensitivity to give a maximum reading then set the y-axis sensitivity on the recorder to give a reading between ½ and full scale. Adjust the potentiometer on the scanning device to the stop at the high voltage end, and adjust the zero on the x-scale of the recorder to read zero. Move the potentiometer to the stop at the low voltage end, and adjust the x-scale sensitivity of the recorder to give a reading slightly less than full scale on the chart.

Manually drive the resolution chart upward until the slit aperture is centered on the dark area below the square light area of the resolution chart. Set the scanner potentiometer to zero and the scanning speed to approximately 3 mm/min. Scan the resolution chart downward automatically and record the photometer and potentiometer outputs until the slit is about centered in the square light area. Then move the resolution chart until the aperture is in the dark area below the -4(1) pattern in the image of the chart, set the potentiometer to zero, and scan automatically at about 3 mm/min, recording until the slit is in the dark area above the pattern.

Move the chart manually to successively smaller patterns and scan automatically until the recorded pattern can no longer be resolved as three distant peaks and two valleys. Then repeat the recording scan across the edge of the large square light area.

The lowest spatial frequency on the viewer output screen should be no higher than 4 line pairs per mm, and a value of 2.5 or less is desirable. To get such low spatial frequencies with night vision devices having objective lenses of less than 50 mm focal length, it may be necessary to use a resolution pattern in the -5 or -6 groups. The fabrication of such patterns is discussed in appendix E.

Compute the magnification factor, M, of the objective lens of the viewer from the focal length, F, and the distance, D, from the resolution chart as

$$M = F/(D-F)$$

Compute the spatial frequency, f, of each pattern image scanned from the magnification, M, and the spatial frequency, f_c, of the pattern on the chart (table 3) as

$$f = f_c/M$$

TABLE 3. *Spatial Frequencies on Resolution Chart*

(Line pairs per millimeter)

Pattern No.	Group No.							
	-6	-5	-4	-3	-2	-1	0	1
1	0.0156	0.0312	0.0625	0.1250	0.2500	0.5000	1.0000	2.0000
2	0.0175	0.0350	0.0702	0.1403	0.2806	0.5612	1.1225	2.2449
3	0.0197	0.0394	0.0787	0.1575	0.3150	0.6300	1.2599	2.5198
4	0.0221	0.0442	0.0884	0.1768	0.3536	0.7071	1.4142	2.8284
5	0.0248	0.0496	0.0992	0.1984	0.3969	0.7937	1.5874	3.1748
6	0.0278	0.0557	0.1114	0.2227	0.4554	0.8909	1.7818	3.5636

Compute the contrast modulation, C_t , at the frequency, f , from the average heights above zero of the peaks, L_D , and the valleys, L_L , of the recorded scan, as

$$C_t = (L_L - L_D) / (L_L + L_D)$$

Compute the contrast of the chart, C_0 , from the average of the two curves made across the edge of the square light area recorded at the beginning and end of the test; $L_{L,0}$ in the light area and $L_{D,0}$ in the dark area:

$$C_0 = (L_{L,0} - L_{D,0}) / (L_{L,0} + L_{D,0})$$

Compute the contrast transfer function, $CTF(f)$, at a frequency, f , from the contrast modulation, C_t , at the frequency, f , and the contrast modulation of the chart, C_0 ;

$$CTF(f) = C_t / C_0$$

Plot the $CTF(f)$ as a function of spatial frequency, f , to produce the CTF curve of the viewer. Draw a smooth line through the plotted points and interpolate the values at the required frequencies.

5.16 Distortion Test

Set up the distortion chart (figure 4) on its adjustable mount in front of a black background at one end of the laboratory, and a surveyor's level at the other end. Adjust the surveyor's level to align its crosshairs with the horizontal and vertical lines at the center of the distortion chart while maintaining its optical axis horizontal. Attach a first-surface plane mirror, at least 12 cm square, to the center of the chart, with the reflecting surface parallel to the surface of the chart. Establish a horizontal reference line, normal to the chart to within 0.5 degree and within 1 cm of its center, by focusing the telescope of the level upon the image of its objective lens, and tilting the chart about its horizontal and vertical axes until the telescope crosshairs are well centered upon the image of the objective lens and the center vertical and horizontal lines of the chart beyond the mirror. Remove the mirror, and suspend a plumb bob through the horizontal reference line midway between the chart and surveyor's level.

Remove the viewer eyepiece, mount the viewer on a stable tripod, and turn it on. Place the viewer in front of the surveyor's level at a distance from the chart such that the chart image fills most of the output screen (see figure 12), and adjust the height of the viewer optical axis to that of the horizontal reference line. Align the optical axis of the viewer with the reference line first by eye, sighting along the top of the viewer and adjusting it until the line of sight passes through the cord of the plumb bob and the center vertical line of the chart. Next, while one person observes the image through the level telescope, a

second person focuses the viewer alternately on the cord and center vertical line of the chart, and adjusts the viewer until both images coincide with the vertical crosshairs of the level telescope. Remove the plumb bob, attach the relay lens and single lens reflex camera to the viewer, and complete the alignment by removing the camera back and adjusting the position of the viewer until the rear element of the camera lens is well centered on the crosshairs of the surveyor's level.

Turn off the room lights and adjust the lights illuminating the chart until the luminance of the light area of the chart is 30 cd/m^2 . Load the camera with high speed (approximately ASA 400) panchromatic film and set the built-in exposure meter to the correct film speed.

Critically focus the viewer on the chart, focus the camera, and photograph the viewer image at $\frac{1}{8}$, $\frac{1}{4}$, $\frac{1}{2}$, 1, 2, 4 and 8 times the exposure indicated by the camera exposure meter. Process the film in accordance with the manufacturer's instructions. Examine the film with a low power microscope and mount the two negatives showing best contrast between $8.25 \times 10 \text{ cm}$ ($3\frac{1}{4} \times 4 \text{ inch}$) slide cover plates.

Place the mounted negatives on the stage of a traveling microscope ($3 \text{ to } 5\times$) that will allow measurement of horizontal and vertical reference distances to within 0.01 mm . Measure the diameter of the viewer screen image on both negatives at approximately 45 degrees to the major axes of the distortion chart grid images and compute the average radius, R of the viewer output screen (see figure 12).

Measure the distance between the two horizontal grid lines on either side of the center

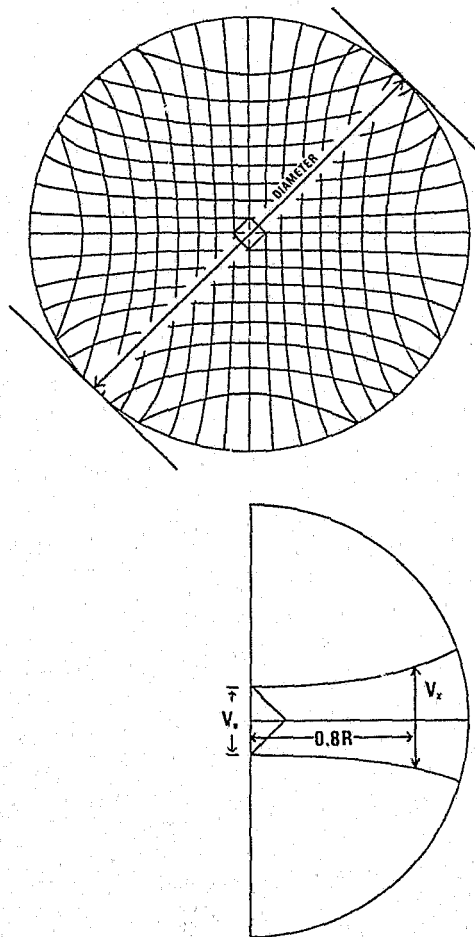

FIGURE 12. Distortion chart image and required measurements.

horizontal grid line at their intersections with the vertical grid line through the origin. Do this five times on each negative and compute the average V_o .

Measure the distance between these same two horizontal grid lines at two points, on each side of and 0.8 R from the vertical line through the center of the chart. R is the radius of the image of the output screen of the viewer (see figure 12). Do this five times on each negative, and compute the average of the 10 values as V_x .

Calculate the percent viewer distortion (%D) as:

$$\%D = \frac{V_x - V_o}{V_o} \times 100$$

5.17 Searchlight Alignment Test

With the viewer still aligned for the distortion test, turn off the lights illuminating the distortion chart, and turn on the searchlight with the infrared filter removed. Measure the straight-line distance from the center of the area of illumination on the chart to the center of the chart. Divide this distance by the distance from the objective lens of the viewer to the chart. From this quotient, the tangent, obtain the angle of misalignment between the optical axis of the viewer and the searchlight beam axis.

5.18 Flare Test

Place the large resolution chart in front of the distortion chart and place the three flare lights with their filaments 4 meters in front of the distortion chart and 1.18 meters from the distortion chart reference line (par. 5.16), one on each side of and level with it and the third directly above it (figure 13). Position the viewer and attached camera with their axes coincidental with the reference line, at a distance from the chart equal to 133 or 95 times the focal length of the viewer objective lens, for viewers with 18 and 25 mm tubes, respectively, such that the flare lights are just outside of the viewer field of view. Tilt the resolution chart slightly forward from its base to eliminate specular reflections into the viewer.

Align each flare light such that its beam is well centered on the objective lens of the viewer. With the flare lights off, illuminate the resolution chart to a level of 10 cd/m² on the light area, critically focus the viewer on the resolution chart, and photograph the scene at the exposure indicated by the camera exposure meter and 1/2 and 2 times this exposure, using high speed panchromatic film. Photograph the scene again at the same three exposures with each of the flare lights in turn illuminating the objective lens of the viewer. Process the film in accordance with the manufacturer's instructions.

Examine the negatives of the scene with flare lights off, using a microscope of about 20 X magnification, and determine for each the smallest pattern that can be seen to consist of three distinct lines. Compute the resolution number R for each negative as

$$R = 1 - P - 6G$$

where G is the group number (always negative on the large resolution chart) and P is the pattern number (always positive) of the smallest resolved pattern.

Identify the negative with the best resolution, or the one which appears to have the highest contrast (judged visually) if two or more have the same resolution, and note the exposure at which it was taken. Calculate the resolution number for each of the three negatives, made with the respective flare lights on, that were taken at this same exposure.

Subtract the largest resolution number of the three flare light scene negatives from that of the negative without flare light. The resulting number is the flare rating of the viewer.

5.19 Searchlight Beam Spread and Luminous Intensity Test

Remove the infrared filter from the searchlight and mount the searchlight on the goni-

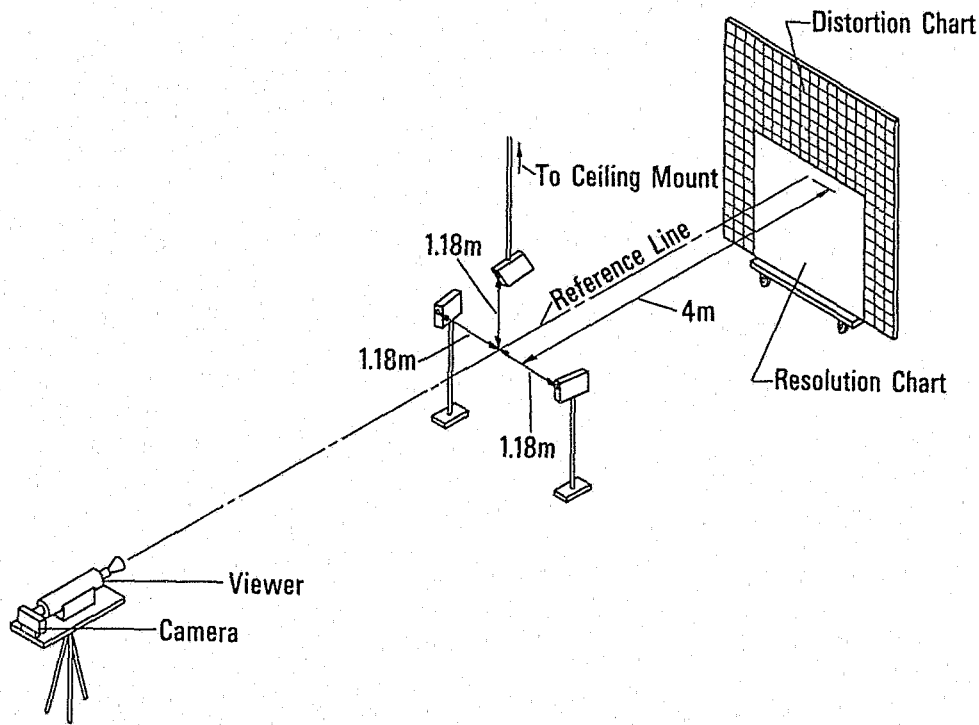

FIGURE 13. Equipment arrangement for flare test.

ometer in the large dark room. Position the photometer with light baffle installed, approximately centered on the optical axis of the searchlight in a horizontal plane, at a minimum distance of 20 m from the filament of the searchlight. Measure this distance to within 2 cm. The baffle must limit the field of view of the photometer such that it receives light only from the searchlight, excluding all light reflected from the walls, floor, and ceiling of the room. Suspend a black velvet curtain behind the searchlight.

Scan the searchlight beam over the photometer, in both azimuth and elevation to determine the position of the searchlight resulting in maximum illumination reaching the photometer. Adjust the goniometer elevation to that for which the maximum illumination was observed, and scan the searchlight in azimuth to the left until the illumination as recorded by the photometer is reduced to 50 percent of the peak illumination. Record this azimuth angle, and scan the searchlight to the right until the illumination recorded by the photometer is reduced to 50 percent of the peak illumination on the other side of the peak illumination and record this azimuth angle.

Position the searchlight to that azimuth angle providing maximum illumination on the photometer and scan the searchlight downward until the illumination recorded by the photometer is at 50 percent of the peak illumination and record this elevation angle. Then scan the searchlight upward, through the peak illumination, until the illumination recorded by the photometer again drops to 50 percent of the peak illumination and record this elevation angle.

The maximum illumination value recorded, in lux, multiplied by the square of the distance D between the searchlight and photometer in square meters is the luminous intensity, I_v , of the searchlight in candelas.

The difference, in degrees, between the two azimuth angles recorded at the 50 percent illumination levels is the horizontal angular beam spread of the searchlight, and the difference, in degrees, between the two elevation angles recorded at the 50 percent illumination levels is the vertical beam spread of the searchlight.

5.20 Effective Range

Calculate the effective intensity of the searchlight, I_T , as

$$I_T = 0.663 I_v \cdot \tau_f \cdot G$$

where I_v is the measured luminous intensity of the searchlight (paragraph 5.19), τ_f is the filter factor as measured (paragraph 5.8), G is the measured optical gain of the viewer (paragraph 5.7), and the factor 0.663 is derived from the relative luminous intensities of light sources at temperatures of 2856 and 3200 K, respectively, that have the same effective radiant intensity. Note that the searchlight operates at 3200 K, while G and τ_f are determined for a source operating at 2856 K.

Compute the effective range of the night vision device, R , in meters, as

$$R = \sqrt{I_T}$$

5.21 Filter Spectral Transmittance Measurement

Measure the spectral transmittance of the infrared filter at 800 nm using a spectrophotometer with a wavelength scale uncertainty of less than 0.3 nm, a bandpass of less than 4.0 nm, and an overall uncertainty in the measured transmittance of less than 10% of the measured value at transmittances above 0.00005.

A suitable instrument is the Cary Model 14 Spectrophotometer for which both the wavelength and photometric scales have been accurately calibrated.

5.22 High and Low Temperature Storage Operation and Thermal Shock Tests

Stabilize the high temperature test chamber at $50 \pm 2^\circ\text{C}$ ($122 \pm 3.6^\circ\text{F}$) and $94 \pm 4\%$ relative humidity. Place the night vision device, which has been stored at room temperature ($22 \pm 2^\circ\text{C}$, $72 \pm 3.6^\circ\text{F}$) for at least 4 hours prior to test, in the chamber for 8 hours. During the last 30 minutes of this period, turn on the night vision device and check to see that a normal image is produced in a dark environment. At the end of the 8 hour period remove the night vision device from the chamber and store it at room temperature for a minimum of 2 hours.

Then place the night vision device in a low temperature test chamber, maintained at $-25 \pm 2^\circ\text{C}$ ($-13 \pm 3.6^\circ\text{F}$), for 10 hours. Turn on the night vision device during the last 30 minutes of this period and check to see that a normal image is produced in a dark environment. A battery pack kept at room temperature (external to the chamber) may be used to operate the unit. Remove the night vision device from the chamber and store for at least 4 hours at room temperature. Turn on the viewer during the last 10 minutes of this period and observe its operation. This completes one cycle of high and low temperature storage, operation and thermal shock. Repeat the complete cycle once. Examine the viewer for evidence of damage immediately following the test.

5.23 Humidity Test

Place the night vision device in a high temperature test chamber at $22 \pm 2^\circ\text{C}$ ($72 \pm 3.6^\circ\text{F}$) and $94 \pm 4\%$ relative humidity for 4 hours. Increase the temperature to 50

$\pm 2^{\circ}\text{C}$ ($122 \pm 3.6^{\circ}\text{F}$) in a period of 2 hours or less, the relative humidity being maintained, and hold at that temperature for 4 hours, then reduce the temperature to 22°C in not more than 2 hours. This constitutes one complete cycle. Repeat the cycle 5 additional times, for a total of 6 cycles. Turn on the night vision device and observe its operation during the last 30 minutes of the 4th and 6th cycles. Examine the viewer for evidence of damage immediately following the test.

APPENDIX A—LIGHT SOURCE

A light source especially designed for the testing of night vision devices is shown in figure 14. It consists essentially of a 1 m diameter integrating sphere, with a 50 cm diameter integrating sphere below and attached to it through an 18 cm diameter iris diaphragm. Four recessed light fixtures are mounted on the lower sphere, 90° apart in a horizontal plane 10.5 cm above the center of the lower sphere, with their axes passing through the center of the sphere, so that they are pointed downward at an angle of about 23.5° to the horizontal. Each fixture is cylindrical, about 13.5 cm in diameter and 14 cm long, and holds one 6.6 ampere, 7 volt General Electric Code Q45PAR 36 airport light. This is a pre-focused quartz-halogen tungsten filament lamp. Each lamp is held in place so that its front surface is recessed about 5 cm from the inner surface of the sphere.

One lamp, identified as No. 1, has a 1.5 mm aperture and an opal glass filter in front of it. A second lamp, identified as No. 2, has an 18 mm aperture and an opal glass filter in front of it. The other two lamps, No. 3 and No. 4, have only a 9.5 cm diameter retaining ring as a limiting aperture. The lamps are connected in parallel, with separate switches. An electronic voltage regulator connected to a nominal 120 volt ac line supply maintains the input voltage constant at 120 volts $\pm 0.1\%$ for line voltage fluctuations from 105 to 135 volts. The output of the voltage regulator is connected to a 2 kVA auto transformer whose output is adjustable from 0 to 135 volts. The output of the variable transformer is connected to the lamps through a 10 to 1 stepdown transformer.

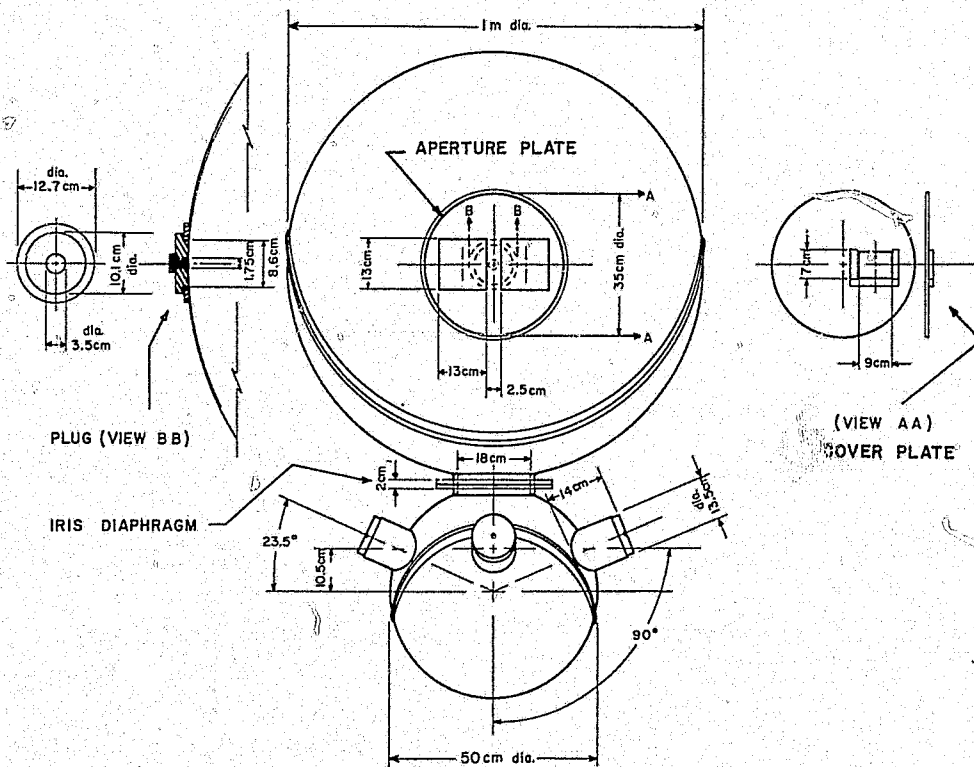

FIGURE 14. Integrating sphere light source.

There is a large aperture, 35 cm in diameter, in the large sphere, which is covered with a removable aperture plate having two apertures, 13 cm square, symmetrically placed 2.5 cm apart on either side of the center of the plate. A removable cover plate over the aperture plate has a single aperture 7×9 cm in size, centered over one of the 13 cm square apertures. The large sphere has a circular hole, 1.75 cm in diameter, diametrically opposite its large aperture. This hole subtends, from the large aperture, a conical solid angle with an included plane angle of 1° . This hole is closed with a removable plug. The inner surface of this plug is concave spherically, with the same radius as the sphere. The plug has a shoulder spaced so that, when inserted with the shoulder in contact with the rim of the hole, the inner surface of the plug conforms to the inner surface of the sphere.

The inner surface of the small sphere is coated with barium sulphate paint.⁷ The inner surface of the large sphere, including the inner surface of all aperture plates and plugs, is coated with Burch sphere paint.⁸ The leaves of the iris diaphragm are of uncoated polished stainless steel.

The color temperature of the light from the large sphere was adjusted to 2856 K with all lights on and the iris diaphragm fully open. A light blue filter⁹ was required to overcome the slight yellowish cast of the Burch sphere paint. With the blue filter in place the voltage to the lamps was varied until the desired color temperature was attained.

The luminance in cd/m^2 of the sphere wall opposite the aperture, with the iris diaphragm closed to its smallest diameter, was as follows: lamp No. 1— 2×10^{-5} , lamp No. 2—0.0026, lamps No. 3 or No. 4—0.22; and with the diaphragm fully open: lamp No. 1—0.005, lamp No. 2—0.9, lamps No. 3 or No. 4—78.

⁷ Available from Eastman Kodak Co., Rochester, N.Y. 14650.

⁸ Available from the Burch Paint Mfg. Co., 10609 Briggs Rd., Cleveland, Ohio.

⁹ Corning type 5900 glass, 2.1 mm (0.083 in.) thick.

APPENDIX B—SCANNING DEVICE

A suitable scanning device is the Motor Driven Meter Mover, Model 31.6,¹⁰ extensively modified for use in these tests. Replace the variable-speed dc motor and control supplied with the unit with a 60 rpm synchronous ac motor having a torque rating of 0.25 newton-meter (2 lbf in.) operating through a reduction gear system having gear ratios of 1, 2.5, 5, 10, 25, 50, 100, 250, 500, and 1000 to 1. The scanning speed at the 50 to 1 gear ratio (1.2 rpm) is 2.82 mm/min.

Connect a 10-turn potentiometer to the drive shaft through a magnetic clutch. Connect a low-voltage source to the potentiometer to produce a voltage that is proportional to the position of the scanner. Magnetic clutches are used to connect the main drive shaft to the scanner and to the potentiometer, because the motor is not reversible, and their use permits the scanner and potentiometer to be repositioned manually between scans.

Replace the chart holding device supplied with the scanner by a platform designed to hold a resolution chart, a viewer or the photometer head.

¹⁰ Manufactured by Hoffman Engineering Corp., P. O. Box 300, Old Greenwich, Conn. 06870.

APPENDIX C—BLACKBODY CAVITY

A suitable blackbody cavity, shown in figure 15, is in the form of an exponential horn. It is made from nominal 2.5 cm O.D. Pyrex brand glass tubing tapered down to a point over a distance of about 12 cm. The tapered section is then bent on about a 6 cm radius to form the cavity.

The inside of the glass cavity is painted with a high-gloss black enamel paint and the outside is painted with a matte black paint. The reflectance of the cavity is less than 0.1%.

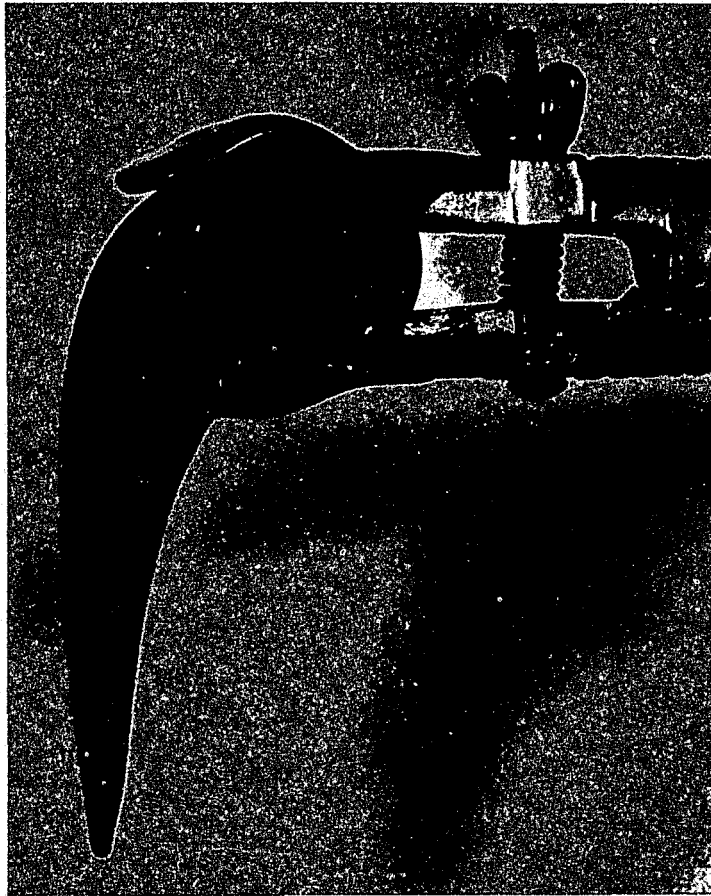

FIGURE 15. *Blackbody cavity.*

APPENDIX D--PLANE SOURCE SPOT

The use of a large area plane illumination source for optical testing of night vision devices requires the use of a black dot for the measurement of light induced background (paragraph 5.11). A circular metal disc of appropriate size may be used as the black spot. The diameter of the disc is 0.0175 times the distance from the objective lens of the viewer to the source. This disc should be painted with a very low reflectance diffusely reflecting black paint, such as Parsons Optical Black,¹¹ or covered with black velvet cloth, and attached to the surface of the diffusing screen with double-faced pressure sensitive tape.

The use of a large-area source requires that the test be made in a darkroom with walls painted with a matte black paint in order to minimize reflection of light from the source back to the surface of the black spot. As an alternative, curtains of black velvet may completely surround the equipment during test.

¹¹ The Eppley Laboratory, Inc., 12 Sheffield Avenue, Newport, Rhode Island 02840, has purchased rights to this coating from the Thomas Parsons Sons Co. of England.

APPENDIX E—LARGE SIZE RESOLUTION CHART PATTERN FABRICATION

For contrast transfer tests (paragraph 5.15) of night vision devices with objective lenses of 50 mm focal length, resolution patterns (figure 1) in the — 5 group are required, and resolution patterns in the —6 group are required for tests of devices with objective lenses of 25 mm focal length. These can be made from brass shim stock, mounted between glass plates. The width of the lines and spaces of the various patterns are as follows, in millimeters.

<i>Pattern No.</i>	<i>Group No.</i>	
	<i>—5</i>	<i>—6</i>
1	16.00	32.00
2	14.25	28.51
3	12.70	25.40
4	11.31	22.63
5	10.08	20.16
6	8.98	17.96