

147792

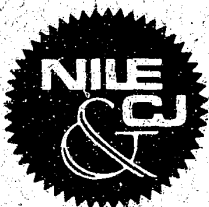

# NEW ENVIRONMENTS FOR THE INCARCERATED



**U.S. DEPARTMENT OF JUSTICE**  
**Law Enforcement Assistance Administration**  
**National Institute of Law Enforcement and Criminal Justice**

83

147792

# **NEW ENVIRONMENTS FOR THE INCARCERATED**

**THIS PUBLICATION CONTAINS REPRINTS  
OF THREE ARTICLES ON CORRECTIONAL  
ARCHITECTURE THAT APPEARED IN THE  
SPRING-SUMMER, 1971 ISSUE OF THE  
PRISON JOURNAL, VOLUME LI, NUMBER 1.  
THE NATIONAL INSTITUTE OF LAW  
ENFORCEMENT AND CRIMINAL JUSTICE  
APPRECIATES THE PERMISSION GRANTED  
BY THE PENNSYLVANIA PRISON SOCIETY  
TO REPRINT THESE ARTICLES.**

**AUGUST 1972**

**U.S. DEPARTMENT OF JUSTICE  
Law Enforcement Assistance Administration  
National Institute of Law Enforcement and Criminal Justice**

147792

**U.S. Department of Justice  
National Institute of Justice**

This document has been reproduced exactly as received from the person or organization originating it. Points of view or opinions stated in this document are those of the authors and do not necessarily represent the official position or policies of the National Institute of Justice.

Permission to reproduce this ~~copyrighted~~ material has been granted by

Public Domain/LEAA

U.S. Department of Justice

to the National Criminal Justice Reference Service (NCJRS).

Further reproduction outside of the NCJRS system requires permission of the ~~copyright~~ owner.

## CONTENTS

---

	PAGE
Foreword .....	3
Introduction by Richard W. Velde .....	5
Observations about Recent Correctional Architecture by Alfred Gilbert .....	7
The Social Psychology of the Cell Environment by Robert Sommer .....	15
Using the Building as a Therapeutic Tool in Youth Treatment by Kenneth Ricci .....	22

## FOREWORD

The recent trend toward community-based corrections has generated some diverse reaction. Optimism has been rekindled, a posture marked by an unshakeable faith that corrections at last has entered into the twentieth century and now is on the path toward building an effective and equitable system. Yet, at the same time, the current interest in corrections has stimulated an awareness of its past and has led to a greater appreciation of the correctional endeavor as it existed in previous centuries. Students of such historical material are quick to point out that many elements of today's highly touted programs have roots in earlier practices. From an historical perspective, innovative programs frequently turn out to be amalgams of outworn techniques, neither new nor particularly likely to succeed.

Yet it should be possible to view the correctional scene without being seduced by short-sighted optimism and without being overwhelmed by cynicism. The recent and massive entry of the federal government into the field of corrections does represent, in historical terms, a real change in the structure of corrections. Whether this structural change will generate valuable substantive change is still uncertain, but the dynamics for movement are present.

One of the first areas which has been selected for federal stimulation and support has been that of correctional design, an area in which there has been little concerted effort or output in recent years. Four of the five articles in this issue of the *Journal* originated in work for which the Law Enforcement Assistance Administration provided support or cooperation. It should be noted routinely that the views expressed by these authors ..... remain their own and do not necessarily represent the views or policies of the Law Enforcement Assistance Administration.

For those who would seek ready-made blueprints and floor plans and for those who would urge the immediate abolition of prisons, these articles will be a disappointment. The authors represented here provide few solutions; rather, they focus on the process of reaching solutions. In doing so, they evidence a refreshingly new range of concerns and it is for this reason that a cautious optimism may well be warranted.

# Introduction

RICHARD W. VELDE  
*Associate Administrator*  
Law Enforcement Assistance Administration

In far too many cases, correctional institutions do not correct or rehabilitate inmates. In far too many cases, the opposite is true: that is, men and women who have the potential for productive lives are made worse.

Past corrections failures stem in part from the inadequate, obsolete, and decrepit physical structures in which many prisoners are housed. Some institutions built as early as the War of 1812 are still in use. The design of such facilities reflects a philosophy inconsistent with modern enlightened correctional programs.

Greater and greater attention has been focused on corrections during the past two years. President Nixon has made corrections improvements a top priority of his national crime control and criminal justice improvement program. Out of a budget of \$530 million, the Law Enforcement Assistance Administration awarded some \$178 million for corrections in 1971.

And in amending the Omnibus Crime Control and Safe Streets Act, Congress recently added a new Part E which authorizes LEAA to make grants to states for "the construction, acquisition and renovation of correctional institutions and facilities, and for the improvement of correctional programs and practices."

But even before the legislation was passed, LEAA began laying the groundwork for effective implementation of the new provision by organizing a task force to develop new standards in correctional architecture. LEAA felt that to duplicate the correctional molds of the early 19th century in 20th century materials would perpetuate shortcomings of corrections into still another century. Traditional design, it was felt, would be a step backward at a time when forward movement is urgently needed.

It soon became apparent to LEAA that little current information was available on the effect of architectural design on the corrections process. Though much correctional construction had been completed in recent years, few facts were available on how well it met operational requirements. It also became apparent that the wealth of ideas and trends in architecture has had slight impact on the design of correctional facilities.

Thus, it seemed essential that LEAA provide a sound basis for

innovation. The Committee on Correctional Architecture drew upon the varied talents of experts in architecture, corrections, management, science, law, and public administration. Out of its efforts emerged a four-point plan to attack the problem of prison design:

- (1) Review and critique of recent construction.
- (2) Establishment of guidelines for correction design embodying the best in current practice.
- (3) Basic research on the design principles applicable to correctional architecture.
- (4) Technical assistance to facilitate use of guidelines.

No plan can be more effective than the capabilities of those who carry it out. LEAA has been fortunate in gaining the services of the enthusiastic and imaginative professionals who accepted the assignment. I commend their reports to the readers of *The Prison Journal*. The benefits of the correctional architecture program go beyond the tangible projects described in this issue, however. In the short space of a year, we have developed a core group of knowledgeable people who can provide technical expertise in a field where virtually none existed before.

---

# Observations about Recent Correctional Architecture

ALFRED GILBERT\*

The primary purpose of the present study is an evaluation of the state of the art in correctional architecture. It is an interdisciplinary effort to understand what is now being done—what's good about it, and what's bad about it. Our modus operandi has been to travel as a team representing the points of view of corrections, psychology, and architecture. We have gone half way through a schedule which will ultimately take us into nearly every state. We are looking at all kinds of facilities designed for all kinds of functions.

The looking has been greatly interesting and informative. The evaluating has been frustrating since any evaluation of anything, architectural or otherwise, presupposes a set of values by which to measure. It has become more and more apparent as our study progresses that no such set of values exists commonly in the minds of most correctional people or even of a modest few. Thus, a good prison to one official is one that has a good security record while to another it is one having a low rate of returnees and to another it is one that is largely self-supporting. To most architects, it is understandably one that has been designed in appropriate response to the design program whether that program's objectives are outmoded or not.

Yet we do, in fact, make judgments every day of our visiting, as though a set of values did exist, and as though we were of a mind as to the way in which a given design solution responds to these values. For example, we might observe that a facility has two-man cells, measuring 5 feet by 7 feet, which are locked day and night. As though there were an absolute standard, we would say that such a condition vis-à-vis that standard is deplorable. We see stand-up counts and day rooms without furniture and we say these things are deplorable.

So we are evaluators in search of values, but never doubting for a moment that in general the state of the art is unhappily apart from the dynamics of the rest of modern society. This separation does provide, however, one criterion by which to evaluate—for in the lag between the advance of society as a whole, and of the correctional system as a part,

---

*\*Mr. Gilbert is an economist by education, a builder and designer by experience. He is presently on the administrative staff of Mitchell/Giurgola Associates, Architects, representing them in the study with The American Foundation Institute of Corrections of which William G. Nagel is Director. The psychologist is Stanton B. Felzer, Ph.D. representing Harry J. Woehr Associates.*



there is implicit the denial that the interest of the individual inmate and the interests of the community are common to each other. Society has apparently been saying that it can move forward with great ideological and technological strides, and the devil take the hindmost.

So at the halfway mark in our study it seems reasonable to say that the interests of the individual offender and those of the community are not generally considered to be the same. This is most evident in the physical plant where elements presumably designed by the community are, to the offender, austere, impersonal, intimidating, sometimes terrifying, and seldom constructive.

To one who has had only a brief acquaintance with the field of corrections, it seems equally apparent that the reconciliation of these interests is crucial to any success in correctional design and to catching up with the dynamics of the rest of society. (Community interests are not nearly as great a consideration in most other project types—an office building, for example, need only be inoffensive and legal.)

The very moment the offender returns to the community he is as much a part of the community as any other person and if his experience in the system has not been of a nature that will contribute to his success in the community, the system has clearly failed and the community interest has not been served after all. If this line of reasoning is to be accepted it would further demand that the design of any correctional facility respond to the needs of the individual and to a great extent to the needs as they are seen *by* the individual. Furthermore, if this criterion were applied as a kind of litmus paper test to every element of design, it would *demand* a resolution of *apparently* irreconcilable principles. If they are in fact irreconcilable, then the originating agency must find a way to change the design program; if they can be reconciled, then the architect's job is straightforward, and a diligent, professional effort should produce a successful design.

In my own view it is the unreconciled elements of design programs (together with many unfortunate anachronisms) that have resulted in so many facilities of questionable merit rather than the failure of the architectural design solution *per se*. In fact, some of the least successful facilities we have seen in terms of this user-interest versus community-interest criterion were apparently designed in direct and appropriate response to the program!

The first illustration which comes to mind is a maximum security diagnostic center for adult male felons that has no recreational facilities at all. There is no exercise yard, no gym, no day room, no physical place to be other than the dormitory, cell, corridor or dining hall. In discussing this with the commissioner's office it became clear that these deficiencies were laid to budgetary limitations and hence were part of

the design program! The architect, at least on this point, could not be faulted. He presumably designed what he was asked to design. The program simply has viewed the inclusion of recreational facilities (user's interest) as incompatible with the budgetary limitations (community's interest).

Had the program resolved this apparent dilemma, it might have accepted fewer of the costly physical constraints in favor of the recreational facilities, which could be viewed as contributing factors to overall security. The savings in reducing the amount of reinforced concrete and electronically operated case hardened steel doors might easily have paid for some recreational spaces and equipment. This reasoning may be simplistic and naïve, but it does seem reasonable that an exercise room is more in the common interest of the offender *and* the community than an extra set of security gates or a closed-circuit television surveillance system.

Simply restated, the proposition suggests that the offender's interest should be the compelling criterion in correctional design. With this in mind, I would like to relate some of the things I have observed while participating in the study. Not all of them are obviously related to the single criterion approach, but it is interesting to see how often it does seem relevant.

### **Observations from the Field**

In contrast to the diagnostic center previously mentioned, there was another in a neighboring state which had an identical function and a similar population mix. There was, however, relative freedom within a secure perimeter. The functions of housing, food service, recreation, and classification/diagnosis were in rather widely dispersed separate buildings. Of 1,000 inmates, 900 had the ability to move among these buildings as their program required and as their leisure time allowed. There was a rather normative scale about the place and a kind of community aspect to the complex.

Nowhere in our tour had we felt less tension. The number of escapes and attempted escapes was almost nil. In the other center, there was a mass break during the first week of operation and many attempts since. The suicide and/or self-mutilation rate was three a week. A few men were literally howling and barking in their cages. It is difficult to see how anyone's interests were being served under these conditions even though the center was built in 1969!

One unique aspect of correctional design came to our attention at the more open of these two institutions. The permanent cadre and the offender-in-process were not supposed to communicate with or relate to each other in any way, yet in the normal course of activities their

pathways crossed! On a college campus, a poorly designed pedestrian traffic pattern like this would likely produce no more than a worn path in the grass in front of old South Hall. In corrections a similar design oversight can mean serious physical personal confrontations and even fertile ground for more general disturbances. In yet another diagnostic center, this kind of traffic problem has perpetuated the mindless, shuffling, silent, single-file movement so clearly antithetical to the *individual* offender's needs. Dressed in white coveralls against a monochromatic gray background and in the artificial glare of fluorescent lighting, the men moved like laboratory zombies in a grade B horror film. How will they move about in society upon release? Whose interests are thereby served?

One of the most striking similarities among the institutions visited is the absence of improvement in the living areas. It seems that the last place anyone wishes to change is there. Cells remain about 5 feet by 7 feet or 8 feet (whether single or double occupancy) and dormitory spaces are almost uniformly 60 inches or less on centers. Other elements improve and expand—notably chapels, recreational areas, day rooms, libraries, et cetera—but not the living spaces. These tend to be minimal by any measurement. Privacy is nonexistent. The ever-present toilet persists—assuring of arbitrarily limiting the offender's movement from the cell. A triangular light fixture at the rear wall ceiling is still very popular despite its limited usefulness. One new county jail has no cell lights at all!

One of the most commonly voiced complaints in our visits was the mass, anonymous, impersonal treatment indigenous to almost every aspect of prison life—in housing where little or no participation in environmental design is possible, in dining where choice is not possible and where dining is really “feeding,” in recreation where one television program must satisfy 40 people and not infrequently where one broadcast station is heard by an entire cell block.

The solutions to these kinds of problems are certainly not simple ones and certainly they are not all architectural. Yet, the failures of the present approaches *are* apparent. It is unfortunate and puzzling to see new facilities being built based on the old philosophies whose perpetuity seems assured by modern construction techniques. One such approach which appears to be dying hard is the no-contact visiting arrangement. There are some new places with open visits and some with family visits, but a surprising number of *new* institutions still have the no-contact arrangement with a row of stools on each side of a partially glazed partition. In one county jail built in 1969, the stools are 22 inches on centers. Another has a stand-up arrangement through a 10-inch by 12-inch window in a door with a perforated steel “talking

screen" below it. One state prison we visited has a telephone system for conversation which distorts the voice beyond recognition.

### Design for Internal and Perimeter Security

Another aspect of prison life is the confinement within confinement. Removal from the free society is not enough. There are additional restrictions to freedom within. As a layman I have often wondered in which manner these additional restrictions are prescribed or even allowed by law. The nature of these constraints seems to be the source of more aggravation as far as the physical environment is concerned than any other single factor. It is, for example, more complained about than the cell size or the amount of dormitory space per se.

In one diagnostic center there were as many as three men in each one-man cell at the time of our visit—one in the bunk and two on mattresses on the floor. The major complaint? "Impossible to keep the place clean." When asked for their feeling about the crowding not one of those interviewed complained about the lack of space itself. They complained about the dirt. They complained about the hard floor to sleep on. This response was surprising until it became apparent that the program of tests and examinations kept them *out* of their cells a great deal of their waking hours and the average length of stay was relatively short. In another center (previously described) there were two men in cells of a similar size, both having wall hung bunks. The attitude in this center was bitter, demonstrably angry, outraged. But here the men were far less frequently out of their cells, and the length of stay averaged 15 weeks—about three times as long as the first institution.

No one would argue that a 5-feet by 7-feet cell is roomy even if occupied by only one man, but it seems to be the nature of movement that counts more than the space itself. (I am reminded of shipboard Navy days when the pipe and canvas bunks were three high in less than 7 feet and the aisles were less than shoulder wide, but sailors were not restricted to the bunk area!) It appeared in many of the places visited that movement was unduly restricted and that the restrictions were a function of physical as much as programmatic considerations. The movement between cell block, corridor, and day room, for example, is frequently prevented by a locked door, which is locked largely because *the door is there and the lock is there*. We did see one such housing unit in which the doors were left unlocked (proving the rule by exception) and nothing seemed to happen except that the tension was clearly diminished. It is more usually the case that internal separations are strictly maintained on the theory that there is a functional relationship between separation and security.

This is a reasonable argument, but in the instance mentioned above

and in several other instances, we have seen that perimeter security is entirely adequate where tensions are eased either programmatically or physically or both. Thus it could be argued that massive internal security with its detrimental impact on the inmate is neither in his interest nor in the interest of the community (since it is expensive and counter-productive).

Well-designed perimeter security on the other hand can be seen to serve the community in terms of protection and the inmate in terms of the security he needs. Not every situation can be satisfied in this way—some facilities properly have no fence at all—but the inclusion of massive internal constraints in new facilities should be seriously questioned by planners and designers alike.

Not every facility which we visited is of a maximum security nature, of course, but the tendency towards steel grillwork is apparently hard to overcome. There are often uneven levels of physical constraints within a given institution. Thus a movement in one direction requires passage through three or four iron doors of the familiar maximum security variety and movement in the opposite direction is contained by only one emergency fire exit to the outside. The question then becomes—why do we need all the grillwork in direction A while the single door is entirely adequate in direction B? In fairness it should be noted that a lot of this grillwork is for the purpose of sectional containment previously mentioned, an objective which might well be reached, however, in other less oppressive and perhaps less costly ways.

In general, there is also a persistent tendency to design and build entire correctional complexes to a single level of security—invariably maximum. This is presumably on the assumption that the potential troublemakers are not known and therefore everyone must be treated as such. This is somewhat puzzling since the inmate population is at all times observable and a great deal is known about each individual. A number of levels of security with relative ease of assignment from one level to the other would seem to serve many interests with very little if any increase in risk.

### **Flexibility in Housing Arrangements**

Aside from the many aspects of security, there has been much discussion both within the study and without about the single cell versus the dormitory. This will doubtless be covered in some detail in our final report, but it is not too early to say that a wide range of housing groupings is needed to operate a facility intended to serve the needs of the individual. We have seen some of this approach in the planning stages—notably a cluster plan for males and one for females in one of the southern states. We have also seen one small unit for juvenile girls

recently opened which has individual rooms arranged in rows which can easily be combined into two-, four-, and six-bed mini-dormitories.

A suggestion along these lines came from a young man who had occupied the same single cell for 11 of his 19 months of incarceration at the time of our visit. He said that the hardest thing for him was the solitude and that it could be remedied by a door between his cell and the next which could be locked motel style whenever either he or his neighbor or the correctional officer on duty wanted it locked.

Paul Charters of the Juvenile Court System in Arizona states the case very distinctly,

“The vast majority of individuals who fall into the criminal justice system have one common problem, their inability to function harmoniously in society with other individuals. By the same token there are those who need some quiet moments and periods of separation during incarceration. Therefore, I would hope that everyone would strive for flexibility of design.”

In many facilities, the most effective antidote to the constraints and boredom of prison life appears to be the recreational program. A range of emphasis among facilities, however, is extreme. Thus, one diagnostic center has a gymnasium and a variety of outdoor activities while another in a neighboring state had none—none at all. Most county and city jails seem also to lack such facilities. The reason given for this in diagnostic centers is the same as in jails—the short duration of stay does not warrant any attempt at programs for rehabilitation. Yet the duration of stay in a diagnostic center can be months instead of weeks and in a jail with the myriad delays of the judicial process the duration is even longer—sometimes as long as two years. It is a programmatic error to assume the holding time to be a matter of a few days or even a few weeks. This is a period of great trauma for many offenders and alleged offenders and great stress for nearly all of them. A relief from the tensions of confinement under these circumstances seems to be obviously desirable, yet the facilities for recreation are almost uniformly lacking.

Near the other end of the spectrum, we have seen a small number of open institutions which, by comparison, are refreshing and heartening. These have been reminiscent of community colleges outwardly and have usually been vocational in program emphasis—very much like training schools. With the exception of the few inmates who need a fence to allay their own feelings of apprehension, the offender populations seem to respond very well to these fenceless prisons. For one thing the environment is more normative and for another there tends to be some bridge to the community or at least a chance of it.

It is interesting to see the more positive attitudes among both inmates and officers at these institutions and to speculate on the effect that the physical openness and normalcy have on the behavior of both. It is tempting to think that here is an example of correctional architecture having a definitely favorable influence on the correctional process; at the very least it is not counterproductive.

Our study has led us to attempt evaluation of much more between these extremes. We have been looking at site locations, treatment programs, size, scale, movement, security, education, recreation, staff needs and many other things. We have been looking almost exclusively at places built within the last 10 years. We are examining the programs and drawings from which these places were built in order to determine if possible, how things got to be the way they are and why things are done the way they are being done now.

Hopefully, we will be able to evaluate what we have seen in terms of the user's interests and needs while not forgetting the interests and needs of the community.

# The Social Psychology of the Cell Environment

Robert Sommer, Ph.D.  
Department of Psychology  
University of California at Davis

MOST OF WHAT WE KNOW about the effect of prison life on inmates has come from autobiographical accounts from the inmates themselves. Without denying the validity of self-report, and the writer has read at least 50 books about prison life done by inmates in several countries and spanning several hundred years' time, there is an urgent need for more systematic investigation of the effects of long-term incarceration. In the biological sciences there is a growing body of literature about the pathological effects of crowding upon both laboratory and free-ranging animals, upon the deleterious effects of an impoverished stimulus environment and the individual's need for varied perceptual experience. If society takes upon itself the task of incarcerating people for long periods of time, it must be aware of the effects of that incarceration. Florence Nightingale had maintained that the first requisite of a hospital was that it made the patients no worse. It seems a minimum criterion of prison effectiveness that an inmate should emerge no worse than when he entered. If we do not know how prison life affects inmates, if we look upon prison as a long tunnel in which a person goes in one end and later emerges out the other, we are likely to compound all the errors of the past and lose the correctional and therapeutic potential of institutional life.

During the past year, I served as a member of a federal task force in correctional architecture. My specific assignment was to pinpoint areas where research was most urgently needed. In this article I will omit consideration of alternatives to incarceration which is being covered by other members of the task force. Instead I will indicate several environmental questions in regard to prisons where research is urgently needed. These are not, I hope, utopian or visionary studies, or research that will require an impossible allocation of manpower and materials, but rather studies that can be done by correctional people and visiting researchers if they have the interest and cooperation of local correction authorities as well as a modest amount of outside support.

## A. The Pathology of Crowding

Prisoners have a selfish interest in research into crowding, since they are so often the unwilling victims of it, but the long range benefits of such



research go far beyond the prison system. Thanks to the work of biologists such as John Calhoun (1960) and J. M. Christian (1962), we are coming to know a great deal about the effects of crowding on animal populations. Death rates increase, reproductive cycles are disrupted, sexual perversions including homosexuality are common, and the customary social order breaks down. Although it is tempting to generalize from these studies to human populations, there are many risks in this procedure. On the other hand, we have very little systematic and useable information on the effects of crowding on human populations. Virtually every description of extreme overcrowding—slave ships, concentration camps or mine disasters—involved outside stresses of such magnitude that it would be illogical to credit a significant portion of the resulting pathology to the crowding itself (Biderman, 1963). Crowded slums also have high unemployment, bad schools, inadequate health services, and virtually every other indication of social disruption, which makes it impossible to say what proportion of these effects can be traced directly to crowding. Laboratory investigations of crowded rooms or civil defense shelters have not fared much better. Generally they involve such short time periods that the volunteers are able to put up with the crowding without ill effects.

Yet the accounts of inmates about prison conditions make it clear that they are bothered by crowding. As one inmate described the women's house of detention in New York City, "The building was simply not built for all these living bodies . . . In my corridor we were two in a very small cell. Whenever you were in your cell, you were either on the toilet or in bed." (Paley, 1966) There is a real need for systematic research into the effects of crowding on human physiology as well as upon attitudes and behaviors. There are some serious moral questions that arise when one proposes to study the effects of noxious conditions on human beings. However, there does exist some precedent in other areas of medical research for dealing with this type of situation. One approach is to survey existing instances of crowding using matched sample techniques between crowded and uncrowded cell blocks and try to isolate out the effects of crowding. This is an economical and fruitful approach if one can find instances where cell blocks with similar facilities have different degrees of crowding. The second possibility is to systematically assign inmate *volunteers* to crowded and uncrowded cells and monitor the results using physiological as well as social-psychological measures. This seems a high priority research project, whose benefits will extend far beyond the prison itself.

### **B. Space Standards**

Research into crowding inevitably brings us to a question which arises any time a correctional facility is planned—the *optimal* size of a single cell. It seems clear that this will vary from culture to culture, even

from one inmate to another, and is influenced by the amount of time that the inmate is able to spend outside this cell. An isolation cell where an inmate spends 23 hours a day should be larger and present a more varied and stimulating environment than a cell in which an inmate is confined only 8 hours a day. I can accept the validity of arguments against national standards for *optimal* living space, but I think there is still good reason to develop space standards based on *minimal* living space. There are many well documented instances of inmates being confined in woefully inadequate amounts of space. The only feasible remedy as well as the most economical is administrative rather than architectural. It is absolutely impossible to design an adequate single cell that can't be used for two inmates. Instead, one must develop a clear standard specifying adequate living space and defining the conditions for temporary exceptions. According to Richard McGee, army prisons define standard living space as 72 square feet per inmate which may go down to 55 square feet if necessary. It cannot go down below this for periods of more than 14 days, and not below 40 square feet in any event. The prison director must report directly to the base commander if the square footage per inmate goes below 55 square feet.

Many states already have standards which they use in programming new institutions. In California a new dormitory in a juvenile hall is expected to have 50 square feet per inmate exclusive of toilet and service areas. The standards for juvenile halls state that the majority of sleeping rooms should be single, with a minimum of 500 cubic feet per room. But these existing standards deal with averages and often have no meaning for the individual inmate. At this time, the actual capacity of California's penal institutions is 24,355 inmates, which is somewhat under its rated capacity. Examining these figures more closely, one finds that the minimum security institutions are under their rated capacity, while the maximum security institutions are overcrowded. Statements about averages have no legal force, they are merely recommendations about optimal densities. What are needed are environmental standards, particularly in regards to *minimum* spatial requirements. This is a high priority task for a specialized team consisting of correctional officials, social scientists, lawyers, and ex-inmates. We would not pretend that minimum space standards will be optimal by any means. Yet their existence will provide some protection to an inmate who is crowded together with one or two other individuals in a cell designed for one man. Minimal space standards would form part of an *environmental bill of rights* for prisoners. It would be ironic if such standards could be developed first in corrections and then spread outwards to the rest of society. I would not predict here the form that such a code would take, whether it would be a statute enacted by the legislature, an administrative rule of a federal or state correctional agency, or a re-

quirement for federal support in corrections. Minimum space standards would assist harried correctional officials in obtaining decent living conditions, which would in turn allow the prison officials to pressure the state for additional facilities or faster processing by the courts or other measures to relieve overcrowding. The standards would probably be of as much use to correctional staff in reducing conditions that produce disturbance, contribute to homosexuality and assaults, as they would to the inmates themselves in improving the quality of life within institutions.

### C. Stimulus Deprivation

There is a considerable amount of research showing the negative effects of sensory deprivation, which range from an inability to concentrate to hallucinations and delusions in extreme cases. In the sensory deprivation research at McGill University, students volunteered to be subjects in the belief that they would get a lot of studying done since there would be a minimum of distractions. Instead they found themselves unable to concentrate (Heron, 1957).

The need for a stimulating and pleasing environment is most urgent in maximum security and isolation areas. Inmates in a community facility who can work in town or visit outside can obtain their quota of stimulation this way. But in isolation or locked cells all day, the inmate's mind will wander. Often one hears the lack of reading in prisons attributed to the "kind of inmate" who is there—uneducated and unintellectual. At least some of this inertia may be due to the drab institutional surroundings. Here is the statement of an educated prisoner who found himself unable to do much reading:

The thought of leaving prison a well-read man was smugly satisfying. Then I discovered that reading—reading intelligently—in prison is not easy, because one of the most difficult things to do in prison is to concentrate. (Heckstall-Smith, 1954)

There is an urgent need for studies devoted to the effects of cell environment on mental functioning. This problem is amenable to experimental investigation. Volunteer inmates can be matched on their score on one form of the mental test, some of them spending the next weeks in barren isolated cells, others in cells with access to the outside, rich in media and amenities. The intellectual functioning as well as their outlook and attitudes can be evaluated every two weeks. A corollary problem involves the effect of incarceration on sensory acuity. Autobiographies of several prisoners (Wildeblood, 1959; Holt, 1935; and Morrell, 1924) report that their senses—particularly smell and hearing—became keener in prison. Some complaints about noise or about odors from the food or toilets may be partially due to sensory *enhancement*. Very little is known about the ef-

fects of long term confinement on sensory abilities. We also need to learn what happens to an inmate's attitudes and his mental abilities when his cell, which was previously barren and unstimulating, is brightened up and made media-rich. It would be possible to compare occupants of these cells before and after the renovations as well as inmates whose cells remain the same.

#### D. Privacy

The lack of privacy, even in institutions containing only single cells, is an almost universal feature of prison life. There have been many efforts to counteract this by giving inmates keys to their own cells and lockers, designing smaller dining rooms and reducing the size of cell blocks. However the economies of dormitory living, particularly in minimum security institutions, are always tempting to the budget-conscious administrator. Other considerations such as reducing conspiracies and encouraging social relationships are often used to buttress the arguments for dormitory accommodations. The trade-offs in terms of reduced privacy are known but are not clearly documented.

Sometimes it seems that privacy for inmates is considered an unnecessary luxury. Army recruits have to live in barracks dormitories, why not prison inmates? The answer is rather complex. First of all, the likelihood of assault, homosexuality, and inmate exploitation is much greater in the prison than in the army barracks. The recruit can go downtown during his free time and he has considerable freedom in walking around the base. I would not underestimate the needs of army recruits for some amount of privacy, but the needs of the prison inmates are more urgent.

Architectural considerations have great influence on the amount of privacy inmates will have. The physical barriers that shield inmates from staff may foster the development of a strong inmate culture with criminal values. Norman Johnston (1961, 1966) recommends against "honor dormitories" and the squad rooms since they tend to increase the strength of the inmate culture. Most wardens object to double cells because of the problems involving assault, homosexuality and exploitation of weaker inmates. Some good research on different sized cells would be a valuable addition to correctional literature. Several accounts written by San Quentin prisoners on the topic "My Home the Prison" express the concern inmates feel about the partner with whom they must share a closet-sized cell:

To see a stranger standing on the tier outside your cell one day with a bundle or box containing his belongings, is similar to what must have been felt by the young Indian brides or husbands when, according to Margaret Mead, they met for the first time *after* they had been married!

These same crowded and barren cells represent a haven for many prisoners against the tension and potential violence of the San Quentin yard. On their free hours during weekends, many inmates return to their cells for a voluntary lock-up for a modicum of privacy and freedom away from the tension of the yard.

Privacy in a single cell is something different than privacy in a dormitory, and freedom from constant staff surveillance may leave the inmates open to exploitation from other inmates. Sometimes privacy means absolute solitude but other times it means the person getting together with one or two friends and chatting or playing cards. The technological means exist to create micro-environments which allow some degree of privacy in group living. Students in college dormitories place their desks so as to minimize eye contact when they are studying. In a prison dormitory, the use of individual high intensity lamps may permit each inmate to regulate his own visual environment without disturbing his neighbors. The placement of the TV set and the location of the bathroom will also affect privacy. Different layouts of dormitories should be studied and compared specifically on the dimension of privacy.

### **Conclusion**

Crowding, privacy, and sensory deprivation are several important aspects of prison life that urgently await experimental investigation. As we have indicated, such research will be of more than academic value. Hopefully it can tell us something about the connection between prison environment and the mental outlook, attitudes, and even the physiology of inmates. Results of such studies, if they do indicate that crowding and sensory deprivation are harmful, will strengthen the arguments for alternatives to prolonged incarceration. They will also help specify the optimal conditions if people must be incarcerated, and at least, they will help us to define the minimum environmental requirements of prisoners. If society sees fit to remove people from the outside and place them in special facilities, it is obligated to learn how those individuals are affected by the conditions of incarceration and as a matter of self-interest, to insure that the correctional environment does not hinder efforts at rehabilitation.

There are many other aspects of prison environment that I have not considered in this brief article. Some of them involve the location of prisons, size and layout, the relationship of the prison to outside agencies, visitor and mail policies, and the design of adequate educational facilities. There is much to be learned from evaluation of existing facilities. I suspect that this is the approach with the highest payoff at this particular time. Sooner or later, we will have to go beyond this and undertake experimental studies which involve before-and-after measures. The kinds of studies that we have described in this article will enable the architect and the correc-

tional administrator to know something of the trade-offs involved in alternative designs. It will help introduce humane considerations into the design process. Some of the points I have raised go far beyond the field of corrections. On my own campus, I have been concerned with the sorts of space standards used in designing classrooms. For the past four years we have systematically evaluated student and teacher satisfaction in one particular room. People start experiencing crowding and a deficiency in ventilation when class size exceeds 17 students. Yet when we checked with the campus administration, we found that according to their policies, the *optimal* class size for this room was 25 students and the maximum was 31. This figure was supplied by the fire chief on the basis of local fire safety codes. I would not deny the value of adequate fire safety regulations, but it seems clear that there are other factors to be considered in defining optimal environmental conditions. This is where information about the social psychology of crowding, privacy, and stimulus deprivation can have a direct and practical input.

#### Bibliography

- Biderman, A. D., Louria, M. and Bacchus, J. *Historical Incidents of Extreme Overcrowding*. Washington: Bureau of Social Science Research, 1963.
- Calhoun, J. B. Population Density and Social Pathology. *Scientific American*, 1962, 206, 139-148.
- Christian, J. J., Flyger, V., and Davis, D. E. Factors in Mass Morality of a Herd of Sika Deer. *Chesapeake Science*, 1960, 1, 79-95.
- Heron, W. The Pathology of Boredom. *Scientific American*, 1957, 196.
- Holt, W. *I Was a Prisoner*. London: John Miles Ltd., 1935, 57.
- Johnston, Norman. Supportive Architecture for Treatment and Research. *The Prison Journal* XLVI, 1966, 15-22.
- Johnston, Norman B. "Recent Solutions: The Criminologists View." *A.I.A. Journal*, July 1961.
- Morrell, E. *The Twenty-fifth Man*. Montclair: New Era Publishing Co., 1924, page 50.
- Paley, Grace. "Killers, Whores, and Jaywalkers." *The Village Voice*, July 28, 1966, page 2.
- Wildeblood, P. *Against the Law*. New York: Julian Messner, 1959, p. 172.

# Using the Building as a Therapeutic Tool in Youth Treatment

KENNETH RICCI\*

While a facility may be designed to avoid the "institutional look" it will nonetheless remain an institution, burdened with all the negative qualities that the term possesses, unless an understanding of the behavioral dimensions of space arrangement can be utilized in its program and design. The various cosmetic attempts to de-institutionalize correction buildings (changing tiled walls for knotty pine, for example) have not shown any observable degree of success and, in fact, demonstrate a misconception of the uses of architectural design. Such cosmetic design may seem innocuous but can presumably be quite harmful, insofar as they deceive staff members into thinking their facility has been "de-institutionalized."

Rather than believe that we can effectively design the institutionality out of a treatment facility, it appears that an approach nearer to reality is to simply assume that every correction or treatment building, regardless of its location, size or architectural style, is considered by its users as an institutional building. It may or may not be a good-looking structure, but for all behavioral purposes it is an extension of a larger social authority.

Like all other buildings it has spaces and furnishings, like all other buildings it has rules—spoken and unspoken—for the use of its spaces. Unlike all other buildings its inhabitants, the adolescents, are involuntary guests. Given this fact, it seems there is very little room to equivocate concerning degrees of the "institutional-looks" at various facilities. A more appropriate and potentially more informative index of institutionality lies in the use of spaces by staff and adolescents.

Once the building is assumed to be an institution, having involuntary users, specific rules for use of spaces and a hierarchic population, it is then possible to use these factors to aid in achieving behavior change in the user group. No longer can we be content to "tone-up" the style of a place or make it look "just like home," while maintaining counter-productive use of space. In the same way that the various social aspects

---

\*Mr. Ricci is an architect engaged in private practice in New York City. His projects have included renovation of the Correctional Association of New York headquarters and Inward House, a drug-free treatment program. He has done work for the New York State Division of Youth, the New York State Narcotics Addiction Control Commission and the Carnegie Endowment for International Peace.

of institutional life—group living, counselling, vocational training, group therapy—are utilized to modulate and change user behavior, it is possible to design and use spatial factors as therapeutic tools.

Perhaps in the same way that counsellors, work supervisors, and youths deal with verbalized feedback from their experiences, the spatial environment could be manipulated experimentally and the results observed, recorded and evaluated as to their impact on program goals. Robert Ezra Park, sociologist, was an early and cautious translator of social dynamics into the realm of space and distance:<sup>1</sup>

“This world of communication and of ‘distances’ in which we all seek to maintain some sort of privacy, personal dignity, and poise, is a dynamic world, and has an order and a character quite its own. In this social and moral order the conception which each of us has of himself is limited by the conception which every other individual, in the same limited world of communication, has of himself, and of every other individual. The consequence is—every individual finds himself in a struggle for status: a struggle to preserve his personal prestige, his point of view, and his self-respect.

“In such a society the individual becomes a person. A person is simply an individual who has somewhere, in some society, social status; but status turns out finally to be a matter of distance—social distance.

“Since so much that students of society are ordinarily interested in seems to be intimately related to position, distribution, and movements in space, it is not impossible that all we ordinarily conceive as social may eventually be construed and described in terms of space and the changes of positions of the individuals within the limits of a natural area.”

Even though the banal distance, that which can be measured by a ruler, between the youth facility and the familial home is quite small, the social distance between these two locales might be quite large; likewise, while boys, staff and administrators inhabit the same small structure, status and its unspoken connotations often order affairs and patterns far more strongly than an architectural plan would suggest. For anyone interested in organizing spatial patterns, insight into the various distances operative within the facility (i.e. status distance, banal distance, aural distance, visual distance) is imperative. Edward Hall, anthropologist, has lately written about the interaction of sensory perceptors

---

<sup>1</sup> Robert E. Park, “The Urban Community as a Spatial Pattern and Moral Order” in Ralph H. Turner, ed., *On Social Control and Collective Behavior*, Chicago: University of Chicago Press, 1967. pp. 63, 67-68.



and cultural patterns, especially the traits of various nationalities; their varying notions of privacy; their tolerance of noise, music, odor. Hall prefers to use the term proxemics for "the interrelated observations and theories of man's use of space as a specialized elaboration of culture."<sup>2</sup>

One behavioral aspect of the spatial environment that has been defined and experimented with thus far is called *territoriality*, an instinct in most forms of life that is dependent on the distance mechanisms built into the various species. The definition of this trait contends that as a result of biological and cultural forces, there in us operates the need to identify and defend certain areas which have meaning for the individual. Relative to the area of youth corrections, the concept of territoriality becomes most apparent through the way in which adolescents will tack up posters, calendars and pin-ups around their bed, and strew clothing on their furniture in an attempt to maintain their own "turf." In a dormitory situation, as opposed to a private room design, the rules for the use of territory suggest that the definition and defense of one's private territory becomes crucial, especially if there is little opportunity elsewhere to gain privacy or a sense of self-identity. Robert Sommer, one investigator who has dealt with the connection of territory and status, states that one is usually a function of the other. When one is in short supply, competition for the other usually increases, often with the drastic results discovered by Calhoun's experiments in overcrowding. Sommer says:<sup>3</sup>

"As a guide to the future, we can draw some analogy from experimental work where the deterioration of dominance relationships within a social system leads to greater reliance on territorial rights."

If this is correct, we might ask if the allocation of little or no well-defined territory to clients results in their searching for status among peers and staff. Likewise, it is possible to speculate that staff, while officially committed to reducing the "Institutional" feeling, actually reinforce their dominance through territorial privileges (space, offices, keys).

If we are to develop the spatial variable effectively as a therapeutic tool, additional experimental situations ought to be created within on-going programs. Initially such experiments would test various combina-

---

<sup>2</sup> Edward T. Hall, *The Hidden Dimension*, Garden City, N. J.: Anchor Books, 1969, p. 1.

<sup>3</sup> Robert Sommer, *Personal Space: The Behavioral Basis of Design*, Englewood Cliffs, N. J.: Prentice-Hall, 1969.

tions of movable furniture. Later on changes in the physical building could be considered using the techniques outlined in this paper. These should not confine themselves to the avant-garde programs only. In fact they would probably be useful in the traditional custodial programs and, indeed, perhaps more necessary.

The negative message of the institutional building comes not solely through the tile-and-steel look but much more forcefully in the pervasive lack of privacy and very flat hierarchy among the youths. Those programs that discard the look and yet retain the substance of custodial programs have not rid themselves of institutionalism. Just as the provision of well-defined, easily defended territory such as a bed, a chair, a locker, a room attempts to support the goals of socialization and self-reliance, so too does the design that creates opportunities for increasing self-regard and peer-group prestige aid in treatment goals. The need for recognition and status is a primary goal of society and is provided to ordinary individuals through group affiliation and achievement in normal society. In the institution the lack of territory, in combination with few opportunities to gain status, together serve to divest the individual of self-identity. The traditional message of the institution is not behavior change but rather dominance.

### **Kitchen and Lounge**

Building design can be used to create and distribute recognition in a therapeutic manner, through the provision of spaces in which status-making episodes can occur. My observations have been that the natural places for adolescents to achieve a little recognition are in the kitchen, workshops or staff offices; namely, in those places that are off-limits generally and into which entry on non-official business is a sign of recognition by the staff member in charge. This recognition can be accrued either by explicit acceptance on the part of the staff member if he shares a space with a boy or by his implicit acceptance if he does not prevent a ward from using an off-limits space. Especially in male-dominated programs (as most are) the presence of a well-liked woman cook will generate a lot of activity near and in the kitchen. One urban youth facility in New York that I know quite well is housed in an old hotel. Inside it resembles countless tenements and apartment houses through the five boroughs. Esthetically, functionally and mechanically this facility is rapidly becoming untenable. Despite its shortcomings, its interior spaces, especially the dining room/kitchen, project a sense of communality. This isn't a sense of mock domesticity, but rather a responsiveness of the people inhabiting these spaces and using them as human places. The cook, a large and robust black woman, seems to be capable of sharing her territory as an extension of herself—her ability

to make the boys in programs feel "at home" is marked. Rules for using her territory are well defined and strictly enforced, as they are in most homes, yet food is abundant at all hours and the atmosphere benign. In this program the cook is the only woman with whom the boys have sustained contact. The presence and presentation of plentiful, good food in an informal way seems to me an important aspect in creating an ambience of affection and trust. From the perspective of my own background it appears that it is via food and eating that children and adolescents receive a message of domestic care and tranquility. Very little is being said about food and its role in the institution.

One of the building's custodians represents another example of the potential of territorial control. The custodian is in charge of the entire building and its upkeep, his official status meanwhile is quite low. The director of the program on the other hand has the highest official status. Yet because of the custodian's territorial mandate, he roams quite easily into any room, even a boy's room (knocking first), remaining immune from the suspicion that might accompany a visit by the director into the same room. In a funny way the custodian, who in this case was quite sensitive to the boys and their situations, became a beneficial force within the program and was recognized as such by the director. So much so, in fact, that when this director moved to another program out of the state, he asked the custodian to come with him.

Those spaces which are expressly designated as on-limits have little value as status-gathering spots. The eternally empty "lounges" of many facilities are an example. Precisely because these spaces are *available* to all, they are unappealing. Appealing spaces are those where there is a little action, a little risk in whether or not one's presence will be allowed (and a mini-victory if it is). The role of design is to provide spaces that will have status-value while being subtly controllable yet not overtly available, for any appearance of availability would diminish that space's appeal. Design, however, is only an initial aspect in the distribution of status and the provision of territory.

The role of staff members in modulating the use of space is the key factor to its therapeutic value. The staff's use of space through regulations, locks and thoughtless habit in many cases stands in contradiction to the progressive treatment goals that the same staff believes in and attempts to achieve. The verbal statements of the program may emphasize the staff's desire to assist in behavior change. The building however, with its gang dormitory and its boy's bathroom complete with plate glass panel facing on a control office, shows no recognition of the role of privacy and the need for dignity. In one particular case, the administration's statement of confidence in young people's potential to perform well as responsible citizens was juxtaposed to the rows of

doorless toilet stalls throughout their youth quarters. In this instance the honest aspirations of staff and administration, verbally expressed so well in policy, counselling and group therapy, were diametrically opposed by the messages of their program's environment.

### **Rugs, Hammers and Locks**

As a practicing architect who is involved in advising and designing new facilities I am forced to ask myself if my own observations are dependable. After overcoming certain minimum standards of modesty I am inclined to answer yes. This answer is based on two reasons. The first is that as a practitioner of the art of building I must have the courage to rely on my own insights and intuitions. Second, as a professional I find very little research being done on present conditions. To be sure there is much being written in the way of insightful critiques on behavior and also a little basic experimentation being done in human ecology and spacing habits.

Curiously enough some of the applied research that is being done is being done by commercial concerns. A carpet manufacturer, for example, has run a five-year comparison of costs between his product and standard vinyl floor tile in an institution setting. He has been able to prove that while initial purchase costs for rug were higher, over a five-year period total purchase and upkeep costs for the rug area were substantially lower than for vinyl tile. In addition to lower costs, carpet adds texture and color to the space and cuts down noise level. The idea for using carpet then on floors, and even walls, in certain areas of a facility is now certainly tenable.

In other cases, program directors have said that furniture built by clients in their own shops was treated with greater care and respect than the standard institutional brand. This wasn't the result of a study, but simply an observation made by staff members and thereafter made into a policy. It certainly costs less to do it that way and this idea fits right into our concept of property rights. In fact, the director of a drug rehabilitation house feels that the architect should design and build only the core of the unit and let the remainder of the building be built by the clients using a very simple design. This is only an escalation of the furniture attitude and while building contractors might not like it, it does, after all, represent the application of knowledge gained after making comparisons. That is what research is all about. This is the type of empirical know-how that is experienced by everyone at his job over a length of time. Because it derives from practical, day-to-day experience it is usually implicitly accepted by most of us. We feel comfortable with it; it has been tried and accepted by others who have had more

experience and know their field. Indeed this is the way the substantial traditions of building were developed and continued in the past.

A program in California experimented with territorial rights as a function of group trust. Of course they didn't call it that. They simply said, if we all trust each other as much as we say we do then we can prove it by taking the locks off our dormitory footlockers. It worked for a while, I understand.

The important point, I think, is that all of these experiences are valuable. Extremely valuable. It is not sufficient for the architect to operate on the basis of insight alone. He must of course, always rely on his abilities to mold space, color, sunlight, structure for human ends. He needs however, a current fund of information on the behavioral impact of the building and its parts. Once the building is considered as a variable in the corrections process this feedback will flow to him, to program planners, to administrators, carrying knowledge of actual performance of the building rather than expected performance.

### **Making the Present Accessible to the Future**

It now is becoming clear that the problem of designing new buildings includes not only the traditional task of designing the structure to serve the current program. We must now develop the ability to design in such a way as to make new structures accessible to the needs of the future. This requires that the building be considered from the outset as a variable in the corrections process and be designed as an adaptable element. Just as staff, inmate population and programs change, the structure itself should be capable of change. Of course, the building's range of adaptability will have to be determined in the program stage, since a building is like any other organism and cannot do more than it is programmed to do. For this reason the concept of "flexibility" must be discarded from our vocabulary, because it implies a universal ability to meet any demand, and replaced with the notion of adaptive design (see Figure 1).

Adaptive design means that currently designed structures be programmed not only to accommodate present goals but also future options. Who can say what these options should be? If the efficient use of a building is to be prolonged over a period of say forty or fifty years—rather than the current seven or eight years—then we must speculate as to the probable changes that will occur and design to facilitate these changes according to their probability.

Any adaptable system, such as the correctional facility, must be able to monitor its own performance in order to determine the difference between the *actual* behavior that occurs and the *expected* behavior originally planned. This monitoring process, called feedback, is

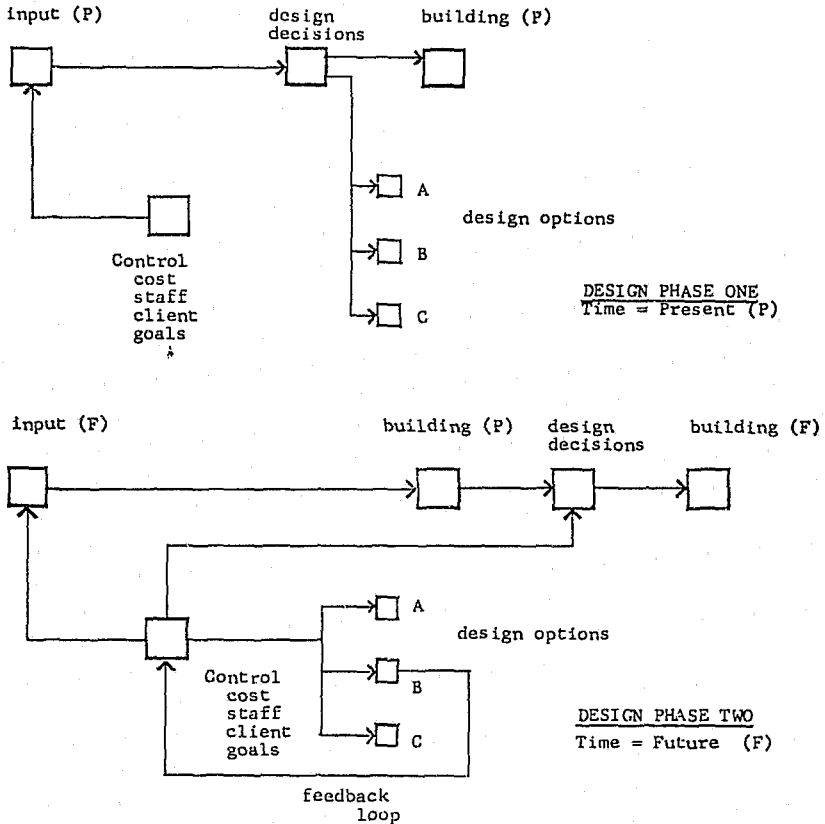

Figure 1: AN ADAPTIVE DESIGN SYSTEM

Design Phase One shows schematically the process where input and design are controlled by cost, staffing, client nature and treatment goals; output is in the form of a building (P) with several built-in options. Design Phase Two shows how, at a future date, input consists of (F) factors as well as the existing building (P). Control is applied to input, design decisions and the selection of the most suitable option—the constraints of this option in turn become part of control. The resultant output, building (F), is thus an adapted statement of the original design.

becoming increasingly recognized in the corrections system and can be profitably extended to include building design (see Figure 2). The adaptable building will be costlier to construct than the conventional one, since the emphasis is on change capability. Yet it would be cheaper to change and consequently would have a longer effective life-span and a longer amortization period.

The development of an adaptive building design approach will include a complete written synopsis of the change capabilities programmed into each new facility. This synopsis then goes into a permanent file in the facility and also at central headquarters. In this way each future local director shall have at his disposal a catalogue of efficient and economical alternatives to his present situation; if any local changes were made, these would be recorded at home-base as well as at headquarters. Likewise, the central administrator would have a complete and up-to-date display of each facility's situation as well as the programmed change capabilities of every facility. All of this information can be depicted with drawings and written material, stored quite permanently on commercially-available plastic sheets.

Making new facilities accessible to the future implies that the alternative to demolish is included among the change variables. Demolition may include the entire structure or selected sub-systems; this decision would depend on an original design decision regarding the various life-spans of the building and its parts. While a concrete structure may be designed for over one hundred years use, a sub-system (heating, electrical, partitions) may be programmed for a useful life of thirty years or thirty months. The sub-system would then be built of materials needed for its programmed life and would be designed for both easy installation and removal. In this way future users of the building would know beforehand the life-spans of various sub-systems, enabling them to adapt to then-current methods and avoid the prohibitive costs of either maintaining an obsolete system or of expensive patchwork to repair the scars after installing a new system. (The savings realized currently by renovation are severely offset by the cut-and-patch work needed to accommodate new sub-systems—plumbing, heating, electrical, partitions—to old structures.) We can design in a way that would make a number of probable alternatives possible at a certain cost, while less probable alternatives would be accessible at a greater cost. Our administrative successors would then have a building whose capabilities could be measured against their program need; the range of alternatives built into the structure might approximate, rather than exactly match, their requirements.

As changes are called for in then-existing buildings, future designers and administrators would review together the capabilities of

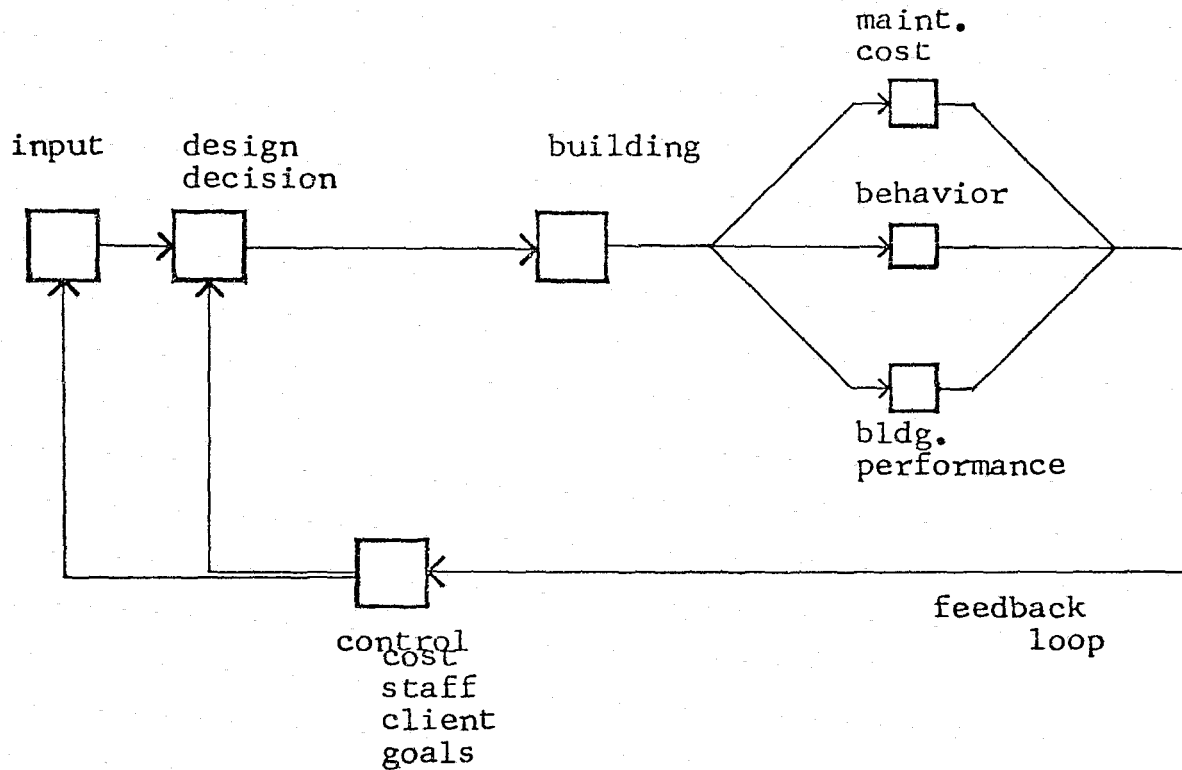

Figure 2: A SCHEMATIC BUILDING EVALUATION SYSTEM

This diagram indicates schematically how the empirical knowledge about the performance of an existing building may be categorized and re-introduced into an evaluation of that building to determine whether the performance of the environment is in keeping with stated program goals. For simplicity's sake this diagram is shown separately; actually it should be linked to Figure One as part of its feedback loop.



their facilities, matching the adaptability of each to their new requirements, and then proceed to a decision based on past performance, estimated cost, disruption of on-going program, etc. (see Figure 2).

The adaptable building provides an approach to a number of currently difficult problems. In facing these problems the building program is based on the belief that the ability to change is an asset. Yet this ability is meaningless if it is a function of caprice rather than a function of information. Information, such as needed for a productive treatment process, is only available through observation and experimentation. In the same way that techniques for measuring the effect of other treatment variables have been devised, techniques for measuring the behavioral effect of the spatial variable are needed. No evaluation of the building as a therapeutic tool is possible without this feedback from clientele behavior.

U.S. DEPARTMENT OF JUSTICE  
LAW ENFORCEMENT ASSISTANCE ADMINISTRATION  
WASHINGTON, D.C. 20530

**OFFICIAL BUSINESS**  
**PENALTY FOR PRIVATE USE \$300**

POSTAGE AND FEES PAID  
U.S. DEPARTMENT OF JUSTICE  
JUS-436



**SPECIAL FOURTH-CLASS RATE  
BOOK**