

GAO

United States General Accounting Office

Report to the Chairman, Subcommittee on Legislation and National Security, Committee on Government Operations, House of Representatives

June 1991

# DRUG CONTROL

## Status Report on DOD Support to Counternarcotics Activities

133433

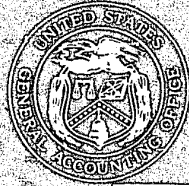

133433

U.S. Department of Justice  
National Institute of Justice

This document has been reproduced exactly as received from the person or organization originating it. Points of view or opinions stated in this document are those of the authors and do not necessarily represent the official position or policies of the National Institute of Justice.

Permission to reproduce this ~~copyrighted~~ material has been granted by

Public Domain

U.S. General Accounting Office

to the National Criminal Justice Reference Service (NCJRS).

Further reproduction outside of the NCJRS system requires permission of the ~~copyright~~ owner.



United States  
General Accounting Office  
Washington, D.C. 20548

133433

**National Security and  
International Affairs Division**

B-242554

June 12, 1991

The Honorable John Conyers, Jr.  
Chairman, Legislation and National  
Security Subcommittee  
Committee on Government Operations  
House of Representatives

Dear Mr. Chairman:

This is the first in a series of reports responding to your request for information on the Department of Defense's implementation of its new counternarcotics responsibilities as set out in the fiscal year 1989 National Defense Authorization Act. Specifically, this status report provides information on the Department's (1) organizational structures established to carry out these responsibilities, (2) intelligence and communications networks devoted to the new counternarcotics mission, (3) overall mission budgeting and funding, and (4) efforts to measure its performance in carrying out its new responsibilities. Future reports will discuss the results of our ongoing detailed reviews of each of these areas—organization, intelligence, communications, and funding.

As arranged with the Subcommittee, we plan no further distribution of this report until 10 days after the date of the report, unless you publicly announce its contents earlier. At that time, we will send copies to the Chairmen, House and Senate Committees on Armed Services and Appropriations; the Secretary of Defense; the Director, Office of National Drug Control Policy; and other interested parties. Copies will also be made available to others on request.

Please contact me on (202) 275-4841 if you or your staff have any questions concerning this report. The major contributors to this report are listed in appendix I.

Sincerely yours,

Louis J. Rodriguez  
Director, Command, Control, Communications,  
and Intelligence Issues

**NCJRS**

**DEC 10 1991**

**ACQUISITIONS**

---

# Executive Summary

---

## Purpose

The Chairman, Subcommittee on Legislation and National Security, House Committee on Government Operations, asked GAO to review the Department of Defense's (DOD) (1) implementation of its new counternarcotics responsibilities, as set out in the fiscal year 1989 National Defense Authorization Act and (2) interagency coordination with the civilian law enforcement agencies (LEA) involved in the drug war. Specifically, GAO was asked to provide information on

- organizational structures that DOD put into place to carry out these responsibilities,
- intelligence and communication networks for the new counternarcotics mission,
- overall mission budgeting and funding, and
- measures of effectiveness used by DOD to evaluate its efforts.

---

## Background

With the increased crime and violence in the 1980s associated with drug use and trafficking, the President declared that the smuggling of illegal drugs into the country was a national security problem. Although DOD had supported LEA counternarcotics activities since 1981, it had not taken a direct role in drug interdiction. As part of the fiscal year 1989 National Defense Authorization Act, Congress gave DOD certain drug interdiction responsibilities that include

- serving as the single lead agency for detecting and monitoring aerial and maritime transit of illegal drugs into the United States and
- integrating U.S. command, control, communications, and technical intelligence assets dedicated to drug interdiction into an effective communications network.

---

## Results in Brief

DOD has organized for the detection and monitoring mission in the same manner that it customarily organizes for its traditional military missions. It established a centralized command structure with regional execution of the operations phase. Through this structure, it also provides intelligence support to LEAS.

DOD has undertaken two major initiatives to establish an integrated communications network. First, with funds appropriated for the counternarcotics mission, it purchased telecommunications equipment for loan to LEAS to facilitate interoperable and secure communications. Second, it established an automated telecommunications information

network to link DOD and LEA drug interdiction operations and intelligence organizations and to provide tracking data on drug smugglers.

Congress appropriated \$300 million in fiscal year 1989, \$450 million in fiscal year 1990, and about \$1.1 billion in fiscal year 1991 for DOD's counternarcotics program. Delays in making funds available to the services for executing counternarcotics projects occurred in fiscal years 1989 and 1990 due mainly to transfer actions necessitated by how Congress directed DOD's use of its counternarcotics funds.

DOD has not finalized specific measures of effectiveness for evaluating its performance in supporting drug interdiction activities; however, according to DOD officials, it is developing such a performance evaluation mechanism.

---

## GAO Analysis

---

### DOD's Detection and Monitoring Organization and Operations

DOD has established an organizational structure for this mission that is similar to that used for DOD's traditional military missions. For policy issues, DOD designated an Assistant Secretary of Defense to be the DOD Coordinator for Drug Enforcement Policy and Support. For operational issues, DOD uses the command and staff structure traditionally employed for other joint missions. The Secretary of Defense delegated operational authority to selected unified and specified command Commanders in Chief. In some cases, the commanders implemented this authority through joint task forces. DOD's organizational strategy emphasizes integrated resources and coordinated operations governmentwide, stressing a cooperative approach to coordinating the participation of its civilian counterparts—LEAS.

---

### DOD's Intelligence Support to Drug Interdiction

DOD supports drug interdiction activities of the law enforcement community by providing drug-related intelligence data. It is committing considerable resources to collecting, analyzing, and disseminating intelligence data on drug trafficking, and it has established an extensive network to conduct and coordinate counternarcotics intelligence activities. Each DOD organization participating in the counternarcotics mission, from the unified and specified commands to individual joint task forces, has either tasked existing intelligence organizations or established new ones to gather, analyze, and disseminate counternarcotics intelligence. These



---

intelligence organizations are developing various data bases and data handling networks to carry out their new counternarcotics mission.

---

### DOD's Communications Support to Drug Interdiction

DOD chose to fulfill its responsibility to establish a communications network through two major initiatives. First, it authorized the Defense Communications Agency to purchase telecommunications equipment to loan to LEAS, using about \$143 million of the total funds Congress appropriated for the counternarcotics mission from fiscal years 1989 to 1991. Second, it developed the Anti-Drug Network, an automated telecommunications information network, to link DOD and LEA drug interdiction operations and intelligence organizations. This system provides graphics-capable terminals at key locations to transmit and display tracking information on suspected drug smugglers.

---

### DOD's Counternarcotics Budgeting and Funding

Prior to the fiscal year 1989 National Defense Authorization Act, DOD had contributed to drug law enforcement in the form of equipment loans, training for LEA officials, and radar coverage of major drug trafficking routes. The act imposed new responsibilities on DOD that were out of cycle with DOD's normal planning, programming, and budgeting system. Additionally, Congress appropriated \$300 million to DOD's drug interdiction account for transfer to operations and maintenance and military personnel appropriations. This transfer of funds would not have enabled DOD to execute its new drug interdiction responsibilities. Therefore, DOD had to request congressional approval to transfer funds, which delayed allocation and distribution of funds to the users. Funding delays also occurred in fiscal year 1990 because funds again had to be transferred and, according to DOD officials, will occur in fiscal year 1991 for the same reason.

---

### Measuring DOD's Effectiveness

Responding to congressional interest, DOD is developing a method for evaluating its performance in carrying out its congressionally mandated mission. DOD has taken the position that its performance or productivity should not be measured against such standards as the number of arrests or the amount of drugs confiscated or destroyed. It maintains that its efforts should be measured against realistic standards, that is, by the quality of its support of the law enforcement community in the implementation of the National Drug Control Strategy. To this end, DOD has queried LEAS on its support and is currently obtaining feedback. DOD plans to use some response data to establish a reporting system on counternarcotics activities.

---

## Recommendations

GAO is not making any recommendations in this report.

---

## Agency Comments

GAO did not obtain written agency comments. However, GAO discussed the information in this report with responsible agency officials and included their technical corrections where appropriate.

<b>Executive Summary</b>		<b>2</b>
<hr/>		
<b>Chapter 1</b>		<b>8</b>
<b>Introduction</b>	DOD's Involvement in the War on Drugs	8
	Objectives, Scope, and Methodology	9
<hr/>		
<b>Chapter 2</b>		<b>11</b>
<b>DOD's Detection and Monitoring Organization and Operations</b>	The President's National Drug Control Strategy	11
	DOD's Counternarcotics Organization	15
	DOD's Concept of Operations for Counternarcotics	15
	LEA Interdiction Organizations and Operations	19
<hr/>		
<b>Chapter 3</b>		<b>21</b>
<b>DOD's Intelligence Support to Drug Interdiction</b>	The Importance of Intelligence	21
	DOD Intelligence Support	22
	LEA Intelligence Activities	24
<hr/>		
<b>Chapter 4</b>		<b>27</b>
<b>DOD's Communications Support to Drug Interdiction</b>	Early Recognition of the Need for Integrated Communications	27
	DOD's Responsibilities and Strategy	27
<hr/>		
<b>Chapter 5</b>		<b>31</b>
<b>DOD's Counternarcotics Budgeting and Funding</b>	Counternarcotics Funding Overview	31
	Project Review Process	34

<b>Chapter 6</b>		35
<b>Measuring the Effectiveness of DOD's Support to Drug Interdiction</b>	Statistical Measures Are Difficult to Develop	35
	Reliable Measures Are Not Available	35
	DOD Suggests Qualitative Performance Measures	36
<b>Appendix</b>	Appendix I: Major Contributors to This Report	38
<b>Table</b>	Table 4.1: Distribution of DOD Counternarcotics Funds for LEA Telecommunications Equipment	29
<b>Figures</b>	Figure 2.1: DOD Detection and Monitoring Organization and the Major Interfacing LEAs	13
	Figure 2.2: Locations of the Major DOD and LEA Organizations	14

**Abbreviations**

C3I	command, control, communications, and intelligence
CINC	Commander in Chief
CINCFOR	Commander in Chief, Forces Command
CINCNOAD	Commander in Chief, North American Aerospace Defense Command
DOD	Department of Defense
GAO	General Accounting Office
JTF	joint task force
LEA	law enforcement agency
NORAD	North American Aerospace Defense Command
USCINCLANT	U.S. Commander in Chief, Atlantic Command
USCINCPAC	U.S. Commander in Chief, Pacific Command
USCINCSO	U.S. Commander in Chief, Southern Command



# Introduction

The smuggling of illegal drugs into the United States became a major national problem in the 1980s as drug use and trafficking increased. The problem became so significant that the President designated drug trafficking and drug use to be a threat to national security. The concern over the drug problem has increased and continues into the 1990s. It is this increased concern that has led Congress to involve the Department of Defense (DOD) in the war on drugs.

## DOD's Involvement in the War on Drugs

Since fiscal year 1981, federal spending to reduce the supply and use of illegal drugs has increased significantly, to a requested total of \$11.7 billion in fiscal year 1992. Prior to fiscal year 1989, counternarcotics responsibilities belonged entirely to the law enforcement agencies (LEA), such as the Drug Enforcement Administration, the U.S. Customs Service, and the U.S. Coast Guard. Until then, DOD supported LEAs by providing training, equipment, aircraft, and other assistance that complemented DOD's regular mission. DOD was reluctant to increase its participation in the war on drugs due, in part, to the restrictions placed on it by the Posse Comitatus Act (18 U.S.C. 1385) of 1878. The act, as amended in 1956, prohibits the use of the Army or the Air Force to execute U.S. laws, except as otherwise permitted by the Constitution or an act of Congress. Although the statute does not include specific reference to the Navy and the Marine Corps, DOD has applied similar restrictions to them as a matter of policy. The purpose of the act is to preclude the use of federal troops in the enforcement of civilian laws, but the act does not prevent providing military assistance to civilian law enforcement.

Concerned about the apparent lack of coordination among LEAs and the limited progress made in interdicting drug smugglers, Congress assigned DOD specific responsibilities as part of the fiscal year 1989 National Defense Authorization Act. Specifically, the act assigned DOD responsibility for

- serving as the single lead federal agency for detecting and monitoring aerial and maritime transit of illegal drugs into the United States;
- integrating U.S. command, control, communications, and technical intelligence assets dedicated to drug interdiction into an effective communications network; and
- approving and funding state governor plans for expanded use of the National Guard in support of drug interdiction and enforcement operations.

Congressionally appropriated funding for the DOD mission in support of drug interdiction is growing. Congress appropriated \$300 million for the DOD mission in fiscal year 1989, \$450 million in fiscal year 1990, and about \$1.1 billion in fiscal year 1991.

## Objectives, Scope, and Methodology

The Chairman, Subcommittee on Legislation and National Security, House Committee on Government Operations, asked us to review (1) DOD's implementation of its new counternarcotics responsibilities, as set out in the fiscal year 1989 National Defense Authorization Act and (2) its interagency coordination with LEAs that are involved in the drug war. Specifically, we were asked to provide information on

- organizational structures that DOD put into place to carry out these responsibilities,
- intelligence and communications networks DOD devoted to the new counternarcotics mission,
- overall mission budgeting and funding, and
- measures of effectiveness used by DOD to evaluate its efforts.

We briefed the Subcommittee's staff and agreed that this report would be the first in a series of planned reports on DOD's efforts to implement its new mission. This report provides the overview information the Chairman requested. Future reports will respond to the Chairman's follow-on request of November 1, 1990, that we perform individual detailed reviews of each of the above areas—organization, intelligence, communications, and funding—addressing, in each, how DOD measures its effectiveness.

To accomplish our objectives, we researched DOD's role in support of drug interdiction by reviewing numerous congressional hearings and prior reports. Within DOD, we concentrated our efforts on headquarters organizations and the U.S. Atlantic Command. We also visited the U.S. Pacific Command, U.S. Forces Command, and North American Aerospace Defense Command. We did not visit the U.S. Southern Command.

At the commands visited, we obtained briefings on the counternarcotics mission and interviewed appropriate personnel and reviewed pertinent documentation in each of the involved functional elements, such as personnel, intelligence, communications, operations, and comptroller. We also asked officials about the status of the development and use of measures of effectiveness for the DOD role in support of drug interdiction at each of the defense and civilian agencies we visited.

In addition to our work within DOD, we interviewed appropriate officials and reviewed selected records and documents at the major federal drug interdiction agencies in Washington, D.C., and at selected field locations that interface with DOD. We conducted this work to obtain the law enforcement community's views on DOD's counternarcotics role and DOD's performance in supporting their interdiction efforts. The agencies we visited included the Customs Service, the Coast Guard, and the Drug Enforcement Administration. We also interviewed officials at Washington headquarters offices of the Office of National Drug Control Policy; the Federal Bureau of Investigation; the Bureau of Alcohol, Tobacco, and Firearms; the U.S. Marshals Service; and the Department of State.

The major types of interdiction operations are air, maritime, and land. Since DOD was given responsibility only in the aerial and maritime area, this report focuses mainly on air and maritime interdiction operations. Because National Guard issues were being addressed in other reviews conducted by us and DOD's Office of the Inspector General, we did not look at National Guard efforts in this review. Our review was performed from January to October 1990 in accordance with generally accepted government auditing standards.

We did not obtain written agency comments. However, we discussed the information in this report with responsible agency officials and included their technical corrections as appropriate.

# DOD's Detection and Monitoring Organization and Operations

DOD has organized for the detection and monitoring mission in the same manner that it customarily organizes for its traditional military missions. For policy issues, DOD designated an Assistant Secretary of Defense to be the DOD Coordinator for Drug Enforcement Policy and Support. For operational issues, DOD uses the command and staff structure it traditionally employs for other joint missions. The Secretary of Defense delegated operational authority for the detection and monitoring mission to Commanders in Chief (CINC) of selected unified and specified commands. In some cases, the CINCS implemented this authority through joint task forces (JTF). DOD emphasizes integrated resources and coordinated operations governmentwide, stressing a cooperative approach to coordinating the participation of its civilian drug interdiction counterparts—LEAS.

## The President's National Drug Control Strategy

The President's National Drug Control Strategy, which was prepared by the Office of the National Drug Control Policy, is the principal guiding policy for the government's war on drugs. The strategy employs a two-pronged attack on the drug problem—demand and supply reduction.

Supply reduction, which is the topic of this report, includes domestic law enforcement investigation and prosecution against traffickers, smuggling interdiction, international activities that are aimed at reducing production in drug source countries, and research and intelligence agendas. Intelligence and communications activities, including some of those that DOD conducts, support not only all of the points of the supply reduction strategy but also the formation of national drug policy and strategy.

The drug interdiction process is composed of a number of functions and activities ranging from initial detection to apprehension. The major functions and their definitions, as used in this report, follow.

- Detection is determining the presence of aircraft or vessels by visual or electronic means.
- Monitoring is tracking or maintaining continuous knowledge of the location of a suspected aircraft or vessel.
- Interception is establishing a position relative to the suspected aircraft or vessel for purposes of monitoring its activities.
- Apprehension is taking into custody the suspected aircraft or vessel, the illegal contraband, and the persons involved.

Aerial interdiction consists of a sequence of activities: detecting potential smugglers, monitoring their aircraft to identify them as high-probability targets, tracking them to their destination, and arresting them and seizing the contraband and the aircraft. Maritime interdiction involves similar sequences with surface vessels, except immediate boarding by law enforcement officials may occur after interception rather than after tracking a ship to its destination.

The fiscal year 1989 National Defense Authorization Act designated DOD as the lead agency for detection and monitoring of aerial and maritime transit of illegal drugs into the United States. However, lead responsibility for the drug interdiction program, exclusive of DOD's detection and monitoring, remained with LEAS. Figure 2.1 shows the detection and monitoring organizational structure for DOD and its major interfacing LEAS discussed in this report. Figure 2.2 shows the location of some of these organizations.

**Chapter 2  
DOD's Detection and Monitoring  
Organization and Operations**

**Figure 2.1: DOD Detection and Monitoring Organization and the Major Interfacing LEAs**

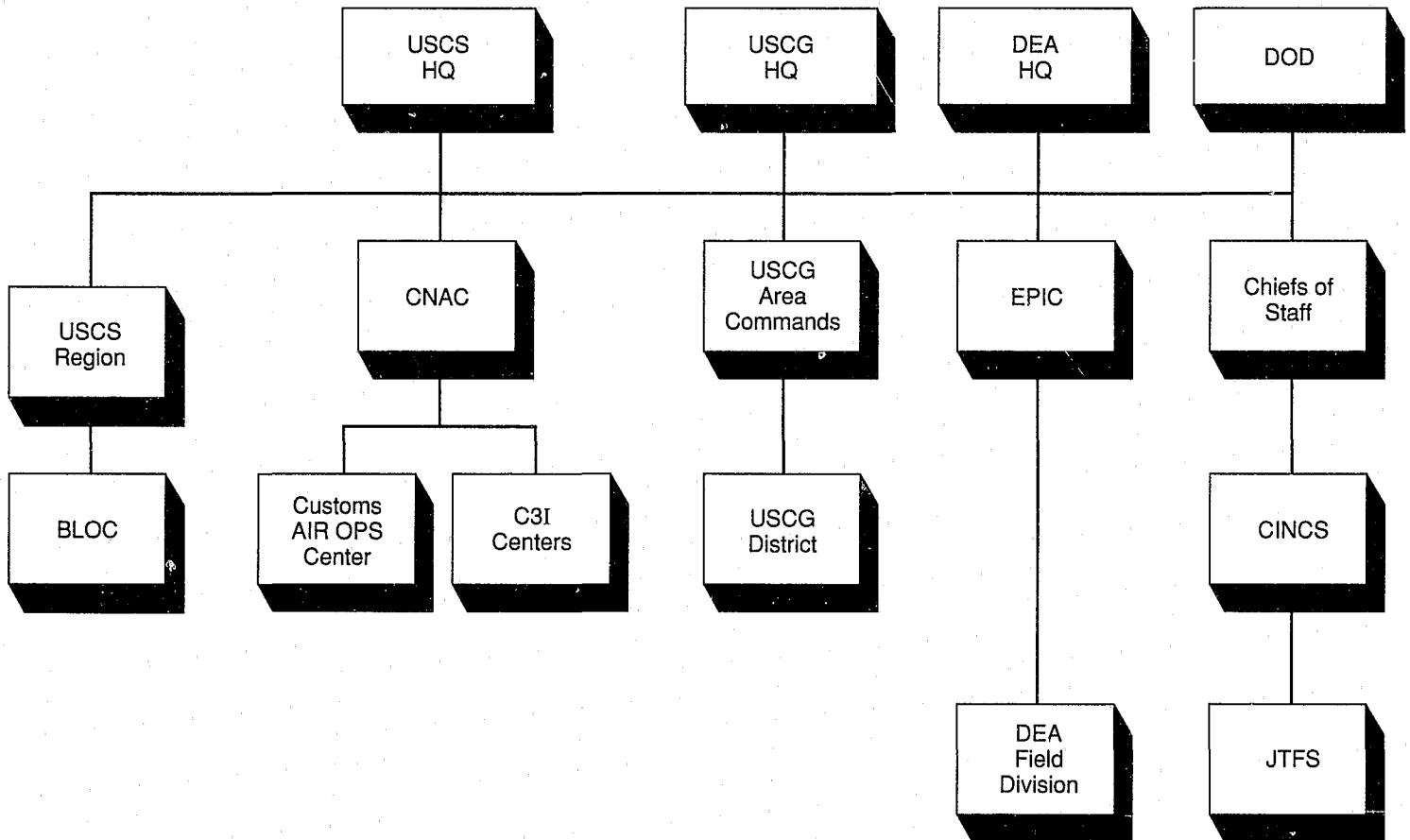

Legend

AIR OPS	Air Operations
BLOC	Blue Lightning Operations Center
C3I	Command, Control, Communications, and Intelligence
CNAC	Customs National Aviation Center
DEA HQ	Drug Enforcement Agency Headquarters
EPIC	El Paso Intelligence Center
USCG	United States Coast Guard
USCS	United States Customs Service

**Chapter 2  
DOD's Detection and Monitoring  
Organization and Operations**

**Figure 2.2: Locations of the Major DOD and LEA Organizations**

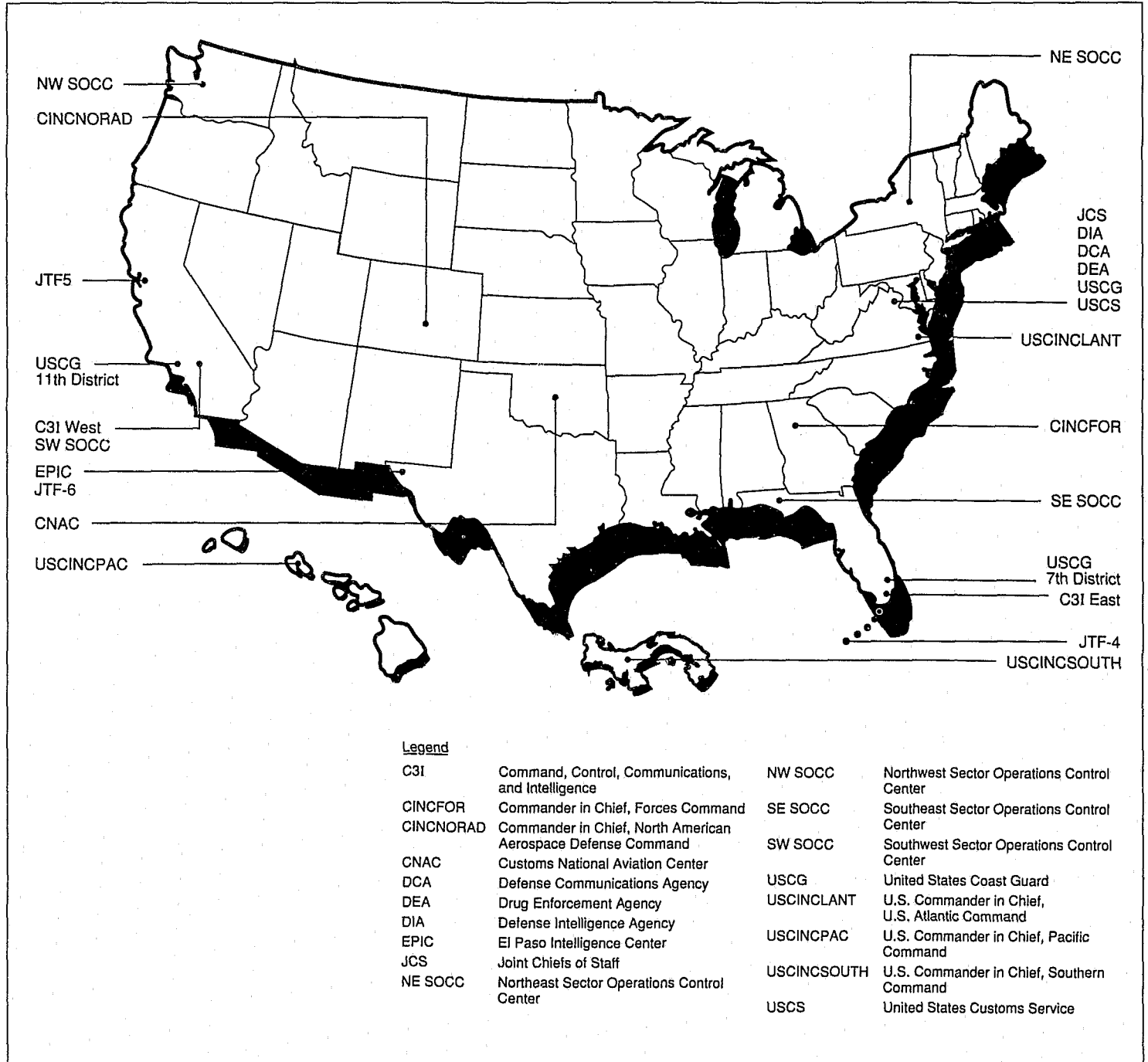



---

## DOD's Counter narcotics Organization

According to the Secretary of Defense, DOD is an active participant in the nation's drug control effort. The Secretary has designated the detection and monitoring of the trafficking of illegal drugs as a high priority mission of DOD and has declared that DOD has a crucial role in defending the United States from the scourge of illegal drugs. The Secretary further stated that DOD would employ the resources at its command to accomplish that mission effectively.

To carry out the legislative mandate, DOD designated a DOD Coordinator for Drug Enforcement Policy and Support to serve as the Secretary's principal staff assistant and advisor for drug control policy, priorities, systems, resources, and programs. Initially established in the Office of the Assistant Secretary of Defense for Force Management and Personnel, the Drug Coordinator's office, and its responsibilities, were transferred to the Office of the Assistant Secretary of Defense for Reserve Affairs. In support of the Secretary and the DOD Drug Coordinator, the Assistant Secretary of Defense for Command, Control, Communications, and Intelligence (C3I) is responsible for guiding and overseeing the planning, programming, budgeting, and acquisition of DOD command, control, communications, and technical intelligence assets and their integration into an effective communications system.

The Chairman, Joint Chiefs of Staff, is responsible for defining the organizational responsibilities and developing the necessary plans to implement the detection and monitoring mission. The Chairman ordered the regional execution of this mission through five CINC organizations—U.S. Atlantic Command (USCINCLANT), U.S. Pacific Command (USCINCPAC), Forces Command (CINCFOR), U.S. Southern Command (USCINCSO), and North American Aerospace Defense Command (CINCNORAD). The Chairman also directed the remaining unified and specified commands to support these CINCS, when appropriate.

---

## DOD's Concept of Operations for Counter narcotics

The DOD concept of operations for the counter narcotics mission provides for regional execution of the operations phase through the CINCS. Within their areas of responsibility, the CINCS plan, schedule, coordinate, and direct DOD detection and monitoring operations in support of LEAS. The detection and monitoring function includes collection of information; correlation, fusion, and analysis of collected information; and dissemination of information and intelligence to LEAS and cooperating foreign governments.

Under this concept, the Army, the Air Force, the Navy, and the Marine Corps provide resources to the CINCs, assist in developing and executing plans, and provide operational support, equipment, training, and personnel to other U.S. agencies and to selected foreign governments. Defense agencies, including the Defense Intelligence Agency, the National Security Agency, the Defense Mapping Agency, and the Defense Communications Agency, also provide the CINCs and LEAs assistance in their respective areas of responsibility and expertise.

Responding to the Secretary's direction, the CINCs have given high priority to the mission and are applying significant resources to organize the effort. USCINCLANT, USCINCPAC, and CINCFOR established subordinate JTF organizational structures to carry out their respective operations and intelligence activities in support of drug interdiction. CINCNOAD and USCINCSO, on the other hand, merged their detection and monitoring responsibilities into their existing organizations and operations.

---

### U.S. Commander in Chief, Atlantic Command

Generally, USCINCLANT is responsible for detection and monitoring operations in the Atlantic Ocean, the Gulf of Mexico, the Caribbean Sea, and portions of the Eastern Pacific. It established JTF-4 in Key West, Florida, to provide a dedicated resource closer to its area of responsibility most affected by drug smuggling. Also, it could use the existing facilities in Key West, which had been recently vacated by the U.S. Caribbean Command.

JTF-4 plans and conducts operations to detect and monitor narcotics traffickers transiting the Caribbean by aircraft or ships from drug exporting countries. Information regarding the detection of suspected traffickers is provided to LEAs responsible for interdicting traffickers. Also, as an intelligence fusion<sup>1</sup> center, JTF-4 plans, coordinates, and conducts intelligence collection, fusion, and dissemination in its area of responsibility.

The Navy's U.S. Atlantic Fleet supports JTF-4 by primarily providing P3 Orion, E2 Hawkeye, and E3 Airborne Warning and Control aircraft for aerial detection and monitoring operations. These operations are conducted under JTF direction or in concert with the joint Customs Service/Coast Guard C3I Center East and Coast Guard District Seven in Miami, Florida. Aerial and maritime detection and monitoring operations include patrols that may be cued searches in a designated patrol area.

---

<sup>1</sup>Fusion is the blending of intelligence information from multiple sources to produce a single intelligence product.

Cued searches are directed at detecting particular smuggling activities through prior intelligence leads.

---

**U.S. Commander in Chief,  
Pacific Command**

Generally, USCINCPAC is responsible for detection and monitoring operations in the Pacific Ocean. USCINCPAC established JTF-5 in Alameda, California, to carry out its detection and monitoring operations. JTF-5 plans, coordinates, and conducts maritime surface and aerial detection and monitoring operations within its area of responsibility. It also plans, coordinates, and conducts intelligence collection, fusion, and dissemination for its area of responsibility.

According to DOD officials, the aerial threat from the Far East is not significant due to the long distances, the need for shipping marijuana and hashish in large bulk quantities for profitability, and the ease of smuggling heroin in small quantities through other conveyances. According to these officials, the primary aerial threat is general aviation aircraft flying coastal routes from Colombia or Central American transshipment areas into northern Mexican destinations. The North American Aerospace Defense Command (NORAD) and the U.S. Navy's Pacific Fleet provide P3, E2, and E3 aircraft to JTF-5 tactical control to conduct detection and monitoring operations off the Mexican Pacific coast.

The maritime threat in the Pacific differs considerably from the threat in the Atlantic Ocean and the Caribbean Sea. Unlike the east coast area of operations, there are few natural choke points that restrict sea lanes and therefore reduce the area requiring detection and monitoring coverage. The west coast area of operation covers the open expanse of the Pacific Ocean. The Pacific Fleet provides aircraft and ships to JTF-5 in support of maritime detection and monitoring operations. These ships and aircraft conduct both random and cued patrols. Random patrols have been the normal and predominant mode of operation since JTF-5 began operating. However, of over 200 boardings conducted by law enforcement officials accompanying JTF-5's random patrols, none resulted in a smuggling discovery or seizure. Consequently, JTF-5 is reevaluating its patrol strategy and is contemplating using patrols primarily for cued searches.

---

**Commander in Chief,  
Forces Command**

CINCFOR is responsible for coordinating all DOD operational support to counternarcotics activities on the ground in the continental United States, particularly along the southwest border. In its support role, it provides transportation, equipment, and training to federal, state, and

---

local LEAS along the southern border. Although it does not have an aerial or maritime detection and monitoring mission, it has established a JTF structure similar to USCINCLANT's and USCINCPAC's. JTF-6 is located at Fort Bliss, El Paso, Texas. DOD chose El Paso because the headquarters for Operation Alliance, an organization of federal, state, and local LEAS operating along the Mexican border, and the Drug Enforcement Administration's El Paso Intelligence Center are located there.

JTF-6 serves as a planning and coordinating headquarters by providing counternarcotics support to federal, state, and local LEAS along the U.S. southern border. In carrying out its counternarcotics mission, JTF-6 primarily interfaces with Operation Alliance, which was established in 1986 to stop the flow of illegal drugs, firearms, currency, aliens, and other contraband across the U.S.-Mexican border. LEAS desiring JTF-6's support for proposed counternarcotics operations must request it through Operation Alliance.

---

Commander in Chief,  
North American  
Aerospace Defense  
Command

CINCNOAD is responsible for detecting and monitoring aerial drug trafficking across U.S. land borders and coastal borders. To conduct its mission, it uses its air defense and Federal Aviation Administration radar networks, mobile ground radars, and aerostats—large tethered balloons outfitted with radar beacons covering low level flights up to 10,000 feet altitude.

NORAD's Tactical Intelligence Cell at Cheyenne Mountain, Colorado, plans, conducts, and coordinates intelligence collection, fusion, and dissemination for its area of responsibility. It disseminates intelligence to its Air Defense Sectors, JTFs, LEAS, and other appropriate agencies. In addition, NORAD's Southeastern Air Defense Sector supports JTF-4 and the C3I Center East by providing radar data to them and launching, at their request, air defense aircraft for monitoring and intercepting suspected targets. NORAD's Southwest Air Defense Sector provides air defense radar data to the C3I Center West and monitors and evaluates the radar and aerostat data itself. In conjunction with this, and in coordination with the C3I Center West, the Sector may also launch aircraft from several locations to intercept and monitor suspected targets when it deems it appropriate or when requested by the C3I Center West.

---

## U.S. Commander in Chief, Southern Command

USCINCSO is responsible for combating production and trafficking of illegal drugs with cooperating South and Central American countries. USCINCSO provides training, operational and maintenance support, material, and advice to the counternarcotics organizations of these countries. It also provides intelligence support to detection and monitoring operations of other commands and LEAS.

---

## LEA Interdiction Organizations and Operations

The Customs Service and the Coast Guard are major drug smuggling interdiction law enforcement agencies. The National Drug Control Strategy designated the Customs Service and the Coast Guard to share the lead agency responsibility for air interdiction, the Coast Guard as the lead agency for maritime interdiction, and the Customs Service as the lead agency for land border interdiction. The Immigration and Naturalization Service's Border Patrol supports land border interdiction, and the Customs Service supports maritime interdiction in coastal waters.

Other federal agencies performing interdiction as part of their law enforcement investigation and prosecution responsibilities include the Drug Enforcement Administration; the Federal Bureau of Investigation; the Bureau of Alcohol, Tobacco, and Firearms; and the Internal Revenue Service. Those agencies with arrest authority may seize contraband when arresting traffickers.

---

## Air Interdiction

The Customs Service and the Coast Guard conduct air interdiction in the Atlantic Ocean, Gulf of Mexico, and Caribbean areas through the C3I Center East. Command of this center alternates every 2 years between these agencies. Air interdiction on the southwest border and Pacific coast is conducted through the C3I Center West at March Air Force Base, Riverside, California. It is operated and controlled only by the Customs Service.

Both C3I centers depend on the use of aerostats that are intended to give contiguous coverage through the Caribbean, the Gulf of Mexico, and along the Mexican border. In addition, both centers use NORAD air defense and Federal Aviation Administration radar network data for radar coverage above altitudes of 5,000 feet. The Customs Service and Coast Guard radar-equipped surveillance aircraft complement this fixed radar coverage. Both use a combination of other aircraft to intercept, identify, and track suspected smugglers.

---

## Maritime Interdiction

As the lead agency for maritime interdiction, the Coast Guard generally concentrates its operations beyond the 12-mile limit outside U.S. territorial waters. Its operations are directed by its Atlantic and Pacific Area Commands in New York and California, respectively. The Area Commands delegate planning and execution of operations to their district commands, with District 7 in Miami, Florida, and District 11 in Long Beach, California, being the most active. District 7 conducts operations in the Atlantic Ocean off the southeast coast and in the Caribbean Sea, and District 11 conducts operations in the Pacific area off the U.S. and Mexican coasts. Maritime operations are controlled through district operations centers.

The Customs Service shares responsibility for maritime interdiction with the Coast Guard at ports of entry in coastal waters—within the 12-mile limit. It conducts these operations through its regional offices. For example, its Blue Lightning Operations Center, located at Miami, Florida, controls its maritime interdiction operations.

# DOD's Intelligence Support to Drug Interdiction

DOD supports the law enforcement community's drug interdiction activities by providing drug-related intelligence data. It is committing considerable resources to collecting, analyzing, and disseminating intelligence data on drug trafficking. DOD has established an extensive network to conduct and coordinate counternarcotics intelligence activities and disseminate results. Each DOD organization participating in the counternarcotics mission, from the unified and specified commands to the individual JTFs, has either tasked existing intelligence organizations or established new ones to gather, analyze, and disseminate counternarcotics intelligence. These intelligence organizations are developing various data bases and data handling networks to assist in their new counternarcotics mission.

## The Importance of Intelligence

In assigning DOD as the lead agency for detecting and monitoring aerial and maritime transit of illegal drugs and in making DOD responsible for establishing an integrated communications network for counternarcotics activities, Congress intended that DOD work with LEAs to integrate all drug-related intelligence data. These data could then be used in planning detection and monitoring operations. Congress believed that for DOD to be successful as the single lead agency for aerial detection and monitoring, the intelligence assets of the various agencies involved in drug interdiction must be integrated and data pertinent to detection and monitoring of drug shipments made available to DOD. Agencies involved in drug interdiction programs at all levels of government agree that accurate and timely intelligence is key to successful drug interdiction.

Individual intelligence collection efforts exist in many agencies. For example, National Foreign Intelligence Community agencies, such as the Central Intelligence Agency, the National Security Agency, and the Defense Intelligence Agency, collect information on foreign nationals, foreign businesses, and overseas property that are involved in drug production and distribution. U.S. law enforcement agencies, such as the Drug Enforcement Administration, the Coast Guard, and the Customs Service, collect information on U.S. citizens, businesses, and property that are involved in drug distribution and sales. Most of these agencies use the intelligence data to support their own operations.

Agencies engaged in drug law enforcement commonly refer to three categories of intelligence—strategic, operational, and tactical. Each of these is defined somewhat differently at times. The following definitions are used for this report.



- Strategic intelligence is evaluated information about broad patterns and trends that is used to make strategic planning and programming decisions, for example, information on illegal drug cultivation, production, availability and location, and methods and routes of trafficking.
- Operational intelligence is information that can provide analytic support to the criminal investigation and prosecution process, for example, information about specific persons, organizations, and facilities such as laboratories and production sites that are engaged in illegal drug activities.
- Tactical intelligence is actionable information that is of immediate tactical use in effecting investigations and interdiction, for example, information about current or imminent location, mode, and movement of specific smuggling activities.

## DOD Intelligence Support

In support of the DOD Drug Coordinator, the Assistant Secretary of Defense, C3I, is responsible for developing DOD counternarcotics intelligence policy. The Assistant Secretary assigned the Director, Defense Intelligence Agency, in coordination with the Director, National Security Agency, responsibility for developing and executing a plan for applying DOD intelligence resources to support narcotics smuggling interdiction. The plan has not been finalized; however, a draft intelligence architecture that is part of the plan is near completion. The architecture is intended to be a first step in the counternarcotics intelligence planning process, forming the basis of DOD's counternarcotics network and describing the counternarcotics responsibilities of the defense intelligence community. In the absence of an approved architecture, individual commands have been adapting their theater-oriented intelligence architectures to include the counternarcotics mission.

DOD has assigned a small staff of intelligence analysts to the Drug Enforcement Administration's intelligence center in Washington, D.C., to help organize and computerize the center's intelligence files. This effort is designed to extract Drug Enforcement Administration information for use in a computerized DOD data base so that sorting and analysis methods used by the National Foreign Intelligence Community can be applied to the files. Drug Enforcement Administration and DOD officials believe that the files can provide a lot of counternarcotics intelligence if they can be properly organized and analyzed.

---

## Defense Intelligence Agency

The Defense Intelligence Agency produces strategic, operational, and tactical counternarcotics intelligence and disseminates it to other DOD and LEA counternarcotics organizations. Detailed intelligence is produced by a centralized unit that conducts all-source analysis of information collected by other intelligence community organizations, LEAs, and the Defense Intelligence Agency's own resources. For example, it produces and provides strategic and operational intelligence packages to USCINCSO in support of Andean region counter-drug activities in South America. The intelligence supports Drug Enforcement Administration agents and cooperating country forces conducting interdiction and crop eradication activities in the region. USCINCSO collects and disseminates unevaluated counternarcotics intelligence back to the Defense Intelligence Agency and other appropriate intelligence organizations.

---

## Unified and Specified Commands

The unified and specified commands, through their respective JTFs or intelligence components, are DOD's primary focal points for identifying, validating, and tasking collection requirements and for disseminating intelligence for detection and monitoring operations to military and civilian counternarcotics agencies. They also coordinate tasking to higher level intelligence organizations when a requirement is beyond their capability.

USCINCLANT, USCINCPAC, and CINCFOR delegate their counternarcotics intelligence responsibilities to their respective JTF intelligence fusion centers. JTF-4 and JTF-5 both have aerial and maritime detection and monitoring missions and have structured their intelligence operations similarly. JTF-6's mission is oriented primarily toward land trafficking of drugs along the U.S. Mexican border. It is working with the El Paso Intelligence Center to develop complementary intelligence systems.

JTF-4 and JTF-5 receive intelligence data and information from national, theater operational (ships and aircraft), and LEA sources and fuse it into products accessible by LEAs in their interdiction operations. To transmit highly classified information to LEAs and other intelligence centers at a classification level appropriate to each element's level of clearance, JTFs downgrade it to eliminate the intelligence source. Intelligence functions are performed by the JTFs' intelligence centers, which are staffed by intelligence analysts. Analysts compile data, such as origin of flight paths, and evaluate their significance to LEA and DOD operations. Analytic results are developed into summaries that are disseminated to other DOD and LEA intelligence and operational activities.

Each JTF is also supported by its respective CINC's intelligence centers. These centers validate intelligence collection requirements that are beyond the JTFs' capabilities to task and, if valid, send these requirements to the Defense Intelligence Agency for tasking national collection assets. In addition, JTF-4 and JTF-5 are supported by subordinate service commands' intelligence centers under USCINCLANT and USCINCPAC, respectively. These intelligence centers perform intelligence functions, such as photo interpretation, that JTFs are less suited for or not capable of performing. To supplement JTF-6's counternarcotics intelligence capabilities, CINCFOR has established an intelligence fusion capability.

Neither CINCNORAD nor USCINCSO has a JTF. CINCNORAD's intelligence functions are conducted primarily by the Tactical Intelligence Cell at its headquarters. In addition, it has small intelligence staffs at its Sector Operational Control Centers that perform limited counternarcotics functions, such as passing information to local command officials. USCINCSO uses its intelligence organization to validate, task, analyze, and disseminate counternarcotics intelligence and to send requirements for additional needed intelligence support to the Joint Staff of the Joint Chiefs of Staff. As mentioned earlier, USCINCSO is supported heavily by the Defense Intelligence Agency.

---

## LEA Intelligence Activities

Federal organizations currently participating in illegal drug supply reduction activities are many and varied. Some are independent agencies; most are in executive branch departments and their subordinate agencies. Although each LEA has its own intelligence organization, counternarcotics intelligence activities at the Drug Enforcement Administration, the Coast Guard, and the Customs Service appear to be the predominant ones that interface with DOD.

---

## Drug Enforcement Administration

The Drug Enforcement Administration is the lead federal agency for enforcing narcotics and controlled substances laws and regulations. It is also the lead federal agency for intelligence supporting drug law enforcement operations. Its mission is the long-term immobilization of major drug trafficking organizations through the prosecution of their leaders and the seizure of assets upon which these organizations depend. One of its primary responsibilities is coordinating and cooperating with other federal, state, and local agencies and with foreign governments in programs that are designed to reduce the availability of illicit drugs in the U.S. market through crop eradication and substitution. Thus, it has established an extensive foreign enforcement program

where its agents work with foreign police forces to identify and destroy clandestine cocaine laboratories and airstrips. In carrying out these programs, it works with DOD in exchanging information that becomes the key tactical intelligence to execute operations safely and effectively.

The Drug Enforcement Administration also is responsible for managing a national narcotics intelligence system in cooperation with federal, state, and local officials to collect, analyze, and disseminate tactical intelligence information. To this end, it established the El Paso Intelligence Center, in 1974, which serves as a clearinghouse for drug information that is collected and processed 24 hours a day. The Center is staffed by special agents and intelligence analysts assigned from the Drug Enforcement Administration; the Coast Guard; the Customs Service; the Federal Bureau of Investigation; the U.S. Marshals Service; the Bureau of Alcohol, Tobacco and Firearms; the Immigration and Naturalization Service; the Federal Aviation Administration; DOD; the Department of State; the Internal Revenue Service; and the Secret Service.

The Center furnishes geographic assessments, estimates, and warnings of drug availability, production, trafficking trends, and routes. It distributes tactical and operational intelligence to federal, state, local, and foreign agencies to support ongoing investigations of traffickers. In 1987, it was designated as the national tactical drug intelligence center.

---

## Customs Service

The Customs Service has responsibility for maritime and air interdiction activities. For example, the Customs Service operates the Miami Blue Lightning Operations Center, which is the principle coordinator of private vessel interdiction in the southeast region. This center analyzes radar data on maritime traffic that has been provided by coastal radars and, on the basis of its analyses, recommends interdiction actions to LEAS. The Miami center also has access to data from aerostat radars that are located at Cudjoe Key, Florida, and Grand Bahama Island.

The Customs Service is responsible for interdicting illegal drugs at air ports of entry, and it shares this responsibility with the Coast Guard in the maritime air area. Identification and sorting of potential traffickers are aided by Federal Aviation Administration radar and air traffic control data as well as NORAD and other military radar. The Customs Service operates two intelligence fusion centers—C3I centers. C3I Center West is located near NORAD's Sector Operation Control Center, March Air Force Base, California. C3I Center East at Miami, Florida, is operated jointly with the Coast Guard. By collating radar tracking data with flight plans

---

and other available intelligence, these centers are able to identify potential targets for interception.

In support of its interdiction efforts, the Customs Service operates an intelligence collection network. Headquartered at Bay St. Louis, Mississippi, this network, using four additional sites, collects intelligence on drug smuggling activities. This information is provided to the Customs Service's air and marine centers and to the El Paso Intelligence Center. Regional intelligence branches at each of its seven regional headquarters provide direct intelligence support to all regional operations. The Custom's National Aviation Center at Oklahoma City, Oklahoma, coordinates air interdiction resources among the seven regions. Other intelligence is provided by its human intelligence teams and special agents.

---

## Coast Guard

The Coast Guard produces drug intelligence to support internal and external customers. It conducts classified and unclassified collection programs in concert with DOD and LEAs. Its Intelligence Coordination Center in Washington, D.C., is a producer of drug intelligence. Its reports include a daily intelligence summary of smuggling activity forecasts and strategic intelligence and operational intelligence products, such as suspect vessel activity.

Coast Guard Area Commanders, and their subordinate District Commanders, produce operational and tactical intelligence in support of the drug interdiction mission and also provide intelligence to JTFs and the two C3I centers. With the Customs Service, it develops information through the Blue Lightning Operations Center to support maritime interdiction operations. Through C3I Center East, the Coast Guard also develops intelligence to interdict airborne drug smuggling activities.

# DOD's Communications Support to Drug Interdiction

DOD chose to fulfill its responsibility for integrating the command, control, communications, and technical intelligence assets into an effective communications network through two major initiatives. The first initiative was to authorize the Defense Communications Agency to purchase telecommunications equipment to loan to LEAS using approximately \$143 million of the total funds Congress appropriated for the counternarcotics mission from fiscal years 1989 to 1991. The second initiative was to develop the Anti-Drug Network, an automated telecommunications information network that linked DOD and LEA drug interdiction operations and intelligence centers.

## Early Recognition of the Need for Integrated Communications

In 1987, the National Drug Policy Board, a committee of federal agency officials created to coordinate counternarcotics resources, established the Inter-Agency Working Group on Drug Enforcement Communications. This group was responsible for developing a telecommunications master plan for drug enforcement. By July 1988, it had developed the National Telecommunications Master Plan for Drug Enforcement that was to serve as a baseline for integrating a communications network to support drug-related operations. In that same year, the Board established the Communications Interoperability Working Group to oversee the implementation of the master plan.

The working group, which is chaired by the Coast Guard, is made up of representatives from the principal agencies that are involved in drug interdiction activities, including DOD. The group's goal is to coordinate implementation of an interoperable and secure communications<sup>1</sup> network. To meet its goal, the group developed the Drug Enforcement Telecommunications Implementation Plan. The implementation plan identified specific secure telephone, radio, and satellite communications equipment needed by LEAS to interconnect voice, data, and record communications among DOD and LEA components. It also specified equipment funding, acquisition, and distribution priorities.

## DOD's Responsibilities and Strategy

The Assistant Secretary of Defense, C3I, has responsibility for coordinating the integration of command, control, communications, and technical intelligence assets into an effective communications network. The Assistant Secretary decided to implement this responsibility with two major initiatives.

<sup>1</sup>Secure communications refer to the use of devices to protect against compromise of communications.

Under the first initiative, the Defense Communications Agency will use approximately \$143 million of the total funds appropriated for the counternarcotics mission from fiscal years 1989 to 1991 to purchase a large portion of the voice and facsimile equipment specified in the implementation plan and to lend it to LEAS. This initiative facilitates the interoperable and secure communications requirements of the plan. The Agency's acquisition strategy for the equipment has been to use existing LEA and DOD equipment purchase contracts.

The second initiative was to develop and implement an automated data network for transferring operations information and intelligence among the various DOD and LEA counternarcotics organizations. This network is known as the Anti-Drug Network. It was developed by the Joint Chiefs of Staff, and it uses interactive graphics-capable terminals to exchange target tracking information and operational messages among network stations.

---

## Equipment Loans

The Defense Communications Agency established memorandums of agreement regarding the communications equipment to be acquired and loaned to LEAS. The agreements stipulate that LEAS will use the equipment primarily for drug enforcement and must return the equipment to DOD when it is needed for other national security concerns. They also specify that LEAS will be responsible for installing, operating, and maintaining the equipment; training personnel to use it; and annually accounting to the Agency on its operational status and custody.

On the basis of equipment fielding schedules in the implementation plan, DOD began acquiring equipment in October 1989. The equipment includes secure fixed network equipment (telephones and facsimile units) and ultrahigh frequency, very high frequency, high frequency, and satellite communications radio equipment. The implementation plan stipulates that after fiscal year 1991, LEAS will be responsible for purchasing any additional equipment outlined in the plan. DOD is distributing the equipment among LEAS also in accordance with agreements in the plan. Table 4.1 shows the distribution of the \$143 million funded for the equipment.



Chapter 4  
DOD's Communications Support to  
Drug Interdiction

**Table 4.1: Distribution of DOD  
Counternarcotics Funds for LEA  
Telecommunications Equipment**

Dollars in millions				
Procurement (Equipment)	Fiscal year			Total
	1989	1990	1991	
Fixed network	\$14.0	\$8.9	\$4.8	\$22.7
Radios				
Very high and ultrahigh frequency	38.7	10.8	30.9	80.4
High frequency	4.1	5.1	9.5	18.7
Satellite communication	.9	0	2.9	3.9
Other project requirements	.4	.3	3.1	3.7
<b>Total</b>	<b>58.1</b>	<b>25.1</b>	<b>51.2</b>	<b>134.4</b>
Operations and maintenance	1.8	1.9	4.8	8.5
<b>Total</b>	<b>\$59.9</b>	<b>\$27.0</b>	<b>\$56.0</b>	<b>\$142.9</b>

The Defense Communications Agency's initial emphasis, as prescribed in the implementation plan, was to provide secure telecommunications capabilities for use on fixed networks, such as the Federal Telecommunications System. Acquisition of DOD-supplied secure telephone and facsimile units is expected to be completed in fiscal year 1991.

The Defense Communications Agency has allocated funds to procure very high frequency and ultrahigh frequency radio equipment to improve interoperability and security of LEAs' very high and ultrahigh frequency radio networks. In addition, the Agency provided funds for the Customs Service to test and develop over-the-air rekeying capability. This capability will supposedly improve the security of portable radio use in drug interdiction operations by permitting a centralized computer to change the coded data in radios "over the air" as they are being used in the field. Current manual methods are time-consuming; thus, many agents do not recode their radios as often as they should, thereby compromising the security of communications. High frequency radio is used by drug enforcement agencies for long-distance communications. The Agency is procuring high frequency radio equipment to upgrade existing LEA high frequency radio networks.

The Defense Communications Agency originally allocated \$3.3 million in fiscal year 1989 for the procurement of satellite communications equipment for LEAs; however, changes in the Agency's priorities led to most of those funds being reallocated to other communications equipment projects. Only \$900,000 of the fiscal year 1989 funds were spent on satellite communications equipment. Since then, the Agency has allocated

\$2.9 million for fiscal year 1991 for the procurement of DOD and commercial satellite terminals for LEA use. Much of law enforcement's current satellite communications connectivity is provided by DOD. According to Agency officials, DOD has limited capacity on its satellite systems for LEA use. The Satellite Technology Working Group, a subgroup under the Communications Interoperability Working Group, is developing an architecture that will address LEA satellite communications requirements. The Agency's current procurement efforts are intended to support immediate satellite communications needs for interdiction agencies.

---

## Interoperable Information Network

The Joint Staff established the Anti-Drug Network to provide a secure, interoperable computer network that would electronically connect multiple DOD and LEA sites, provide common access to fused narcotics data, and take advantage of existing resources to transmit timely tactical intelligence information. In developing the network, the Joint Staff adapted an existing DOD information system and used the Defense Data Network for data transmission.

The system provides graphics-capable terminals at key operations, intelligence, and staff locations to transmit and display tracking information on suspected drug smuggling targets. It also has an electronic mail system for transmitting messages that expands on target information or disseminates other intelligence. This capability is being expanded to include real-time radar data and to provide access to key DOD and LEA interdiction intelligence data bases.

As of January 1991, network terminals were in operation at about 45 DOD and LEA operations and intelligence centers. DOD plans to install about 200 terminals at various locations throughout the country. From its detection and monitoring funds, DOD allocated \$3.8 million for the Anti-Drug Network in fiscal year 1989, \$2.6 million in fiscal year 1990, and \$7.2 million in fiscal year 1991. DOD estimates total costs for the system at about \$36 million through fiscal year 1996, including operations and maintenance. Although DOD is procuring this system using its detection and monitoring funds, LEAs will be responsible for operating and maintaining terminals installed at their locations and for the hardware costs of the terminals installed after fiscal year 1991.

# DOD's Counternarcotics Budgeting and Funding

The fiscal year 1989 National Defense Authorization Act imposed new responsibilities on DOD that were out of cycle with DOD's normal planning, programming, and budgeting system. Additionally, Congress appropriated \$300 million to DOD's drug interdiction account for transfer to operations and maintenance and military personnel appropriations. This transfer of funds would not have enabled DOD to execute its new drug interdiction responsibilities. Therefore, DOD had to request congressional approval to transfer certain funds to other appropriations accounts, which delayed allocation and distribution of the funds to users. Funding delays also occurred in fiscal year 1990 and, according to DOD officials, will occur in fiscal year 1991 for the same reason.

## Counternarcotics Funding Overview

Before passage of the fiscal year 1989 National Defense Authorization Act, DOD contributed to drug law enforcement by providing, on a nonreimbursable basis, equipment loans, training for LEA officials, and radar coverage of major drug trafficking routes. For example, during fiscal year 1988, DOD estimated that it supported LEAs by providing over 28,000 flight hours of aerial surveillance and over 2,000 ship days to the Coast Guard maritime program. With passage of the act, Congress not only formally assigned counternarcotics responsibilities to DOD but also provided \$300 million to DOD to carry out its new responsibilities. Congress appropriated \$450 million in fiscal year 1990 for DOD's counternarcotics program and about \$1.1 billion to fund DOD's fiscal year 1991 program.

To fulfill DOD's responsibilities, the Secretary of Defense designated the Assistant Secretary of Defense, Reserve Affairs, as the DOD Drug Coordinator and established the Office of DOD Coordinator for Drug Enforcement Policy and Support. The Coordinator is responsible for primarily, among other things (1) establishing policy guidelines, (2) providing oversight and monitoring, and (3) programming and budgeting for the DOD counternarcotics program. CINCs carry out the drug program within their respective areas of responsibility. The Joint Staff assists the Coordinator by providing programming and budgeting information that has been obtained from the CINCs on counternarcotics projects related to detection and monitoring efforts.

## Program Funding

The new drug interdiction responsibilities were imposed on DOD by the fiscal year 1989 authorization act relatively unexpectedly and were out

of cycle from DOD's normal planning, programming, and budgeting process. Additionally, as explained below, Congress appropriated \$300 million into DOD's drug interdiction account for transfer to operations and maintenance and military personnel appropriations. This transfer of funds would not have enabled DOD to execute the programs. Therefore, DOD had to request congressional approval to transfer funds to other appropriation accounts, which in some cases, delayed the allocation and distribution of funds to the users. Funding delays also occurred in fiscal year 1990 mainly because funds again had to be transferred.

### Fiscal Year 1989 Funding

In appropriating \$300 million for DOD to carry out its new counternarcotics responsibilities, Congress specified that (1) at least \$40 million be used for National Guard activities, (2) the Secretary of Defense report on how the \$300 million would be used, and (3) no more than \$30 million could be obligated or expended until 30 days after the Secretary's report was submitted. On February 15, 1989, DOD submitted its report, including its plan to allocate \$40 million to the National Guard as set out in the legislation, \$60 million for the communications systems integration plan established by the Communications Interoperability Working Group, and \$200 million for detection and monitoring activities.

Congress appropriated the \$300 million for DOD's counternarcotics program into operations and maintenance and military personnel. From April to July 1989, based on input from CINCS, services, and defense agencies, the Drug Coordinator's office determined what transfer actions had to be taken to move these funds to those appropriations accounts that would allow DOD to execute the proposed counternarcotics program—procurement and research and development. The military and defense agencies provided applicable appropriations details for the office to prepare the transfer documents.

During this time, the Coordinator's office processed seven internal transfers totaling about \$106 million. On July 7 and 10, 1989, the office submitted two transfer requests for congressional approval totaling about \$194 million—\$192.1 million for procurement and \$1.5 million for research and development. On August 8, 1989, 10 months into the fiscal year, the transfer action for procurements was approved. The transfer action for research and development was never approved; however, the Drug Coordinator's office was able to effect an internal transfer of the \$1.5 million before September 30, 1989. Operations and maintenance and military personnel funds are classified as 1-year monies and, if these fiscal year 1989 funds were not obligated by September 30, 1989,

they would no longer be available to DOD. Of the \$300 million appropriation, DOD was unable to obligate about \$13 million by September 30, 1989.

### Fiscal Year 1990 Funding

On November 21, 1989, Congress appropriated \$450 million for DOD's counternarcotics program, earmarking \$139.3 million for projects not requested as part of DOD's proposed program. Funds were approved for the following functional categories: \$88.2 million for operations and maintenance; \$10.4 million for research and development; \$3.7 million for military construction; \$110 million for National Guard; and \$237.7 million for procurement. However, the amounts approved for operations and maintenance and research and development were not enough to meet the requirements in DOD's original budget or the CINC's enhancements proposed subsequent to that budget. As we reported in 1990, these shortages and the congressionally directed projects required DOD to again prepare and submit requests for funding transfers.<sup>1</sup>

By January 1990, sequestration issues were resolved, and in February 1990, DOD submitted its first transfer request to Congress. DOD continued working on the remaining transfer actions and conducted detailed reviews of all projects to determine if they were related to the National Foreign Intelligence Program. The House Conference Report on DOD's fiscal year 1990 appropriations instructed that any transfer actions related to the program be reviewed and approved by the House and Senate Intelligence Committees. On the basis of these reviews, DOD had to obtain prior congressional approval for additional transfer actions. By May 1990, DOD had completed all transfers and had requested congressional approval when appropriate. According to DOD officials, by the end of fiscal year 1990, about \$41 million of the transfer actions had still not been approved.

### Impact of Delays on Project Execution

DOD allocated counternarcotics funds late in fiscal years 1989 and 1990 primarily due to required reprogramming actions. While project managers noted that this was inconvenient and had to be worked around through temporary transfers of funding from other projects, they did not cite any major adverse effects resulting from the late release of funds. Further, service comptrollers we talked to expressed similar frustration with the late receipt of funds but were unable to cite cases where the delays adversely affected counternarcotics project execution. DOD

<sup>1</sup>Drug Control: Status of Obligations for Fiscal Year 1990 DOD Counternarcotics Funds (GAO/NSIAD-90-296FS, Sept., 25, 1990).

officials reported that the need to reprogram and transfer fiscal year 1991 funds would result in similar delays in allocating funds.

## Project Review Process

Each project included in the DOD counternarcotics program is reviewed before being approved and funded. In April 1989, the DOD Drug Coordinator, through the Joint Chiefs of Staff, requested the CINCS, the military services, and the defense agencies to submit their operational (project proposals) requirements for supporting DOD's detection and monitoring mission. According to DOD officials, a total of 180 projects was submitted to the Joint Staff from the CINCS. During April and May 1989, the projects were reviewed by a working group with representatives from the (1) Joint Staff, (2) military services, (3) defense agencies, (4) Defense Intelligence Agency's General Defense Intelligence Program, (5) DOD Drug Enforcement Policy and Support Office, and (6) Assistant Secretary of Defense, C3I.

According to DOD officials, the working group prioritized the projects to compete for the \$200 million available for detection and monitoring for fiscal year 1989. The criteria were (1) did they contribute to the mission, (2) did any project duplicate another, and (3) did the project have a military as well as a counternarcotics mission. Finally, the list of prioritized projects was provided to the DOD Drug Coordinator for his consideration. The Coordinator approved the fiscal year DOD 1989 counternarcotics program of 77 projects on May 23, 1989. According to officials, DOD conducted a similar review for the fiscal year 1990 counternarcotics program that included about 180 projects.

On August 24, 1990, the DOD Drug Coordinator's office notified the military services and the defense agencies that project reviews would be held on or about May 1 of each fiscal year. The purpose of these reviews is to identify projects that are experiencing problems.

# Measuring the Effectiveness of DOD's Support to Drug Interdiction

DOD has not finalized specific measures of effectiveness for evaluating its performance in carrying out its congressionally mandated mission. DOD believes that its performance should not be measured against such standards as number of arrests or number of pounds of drugs confiscated or destroyed. DOD readily admits that this is not to say that its performance should not be evaluated. It maintains that its efforts should be measured by the quality of its support of the law enforcement community in the implementation of the National Drug Control Strategy. According to DOD officials, it is developing a methodology that will provide an assessment of its performance.

## Statistical Measures Are Difficult to Develop

The provisions of the Posse Comitatus statute place strict limitations on the authority of the Armed Forces to make arrests and conduct seizures. Although DOD is the lead agency in detection and monitoring, it cannot apprehend drug smugglers. When DOD tracks a suspected smuggler, it must pass on the information to the appropriate LEA for the actual arrest and seizure. Due to the number of agencies that may get involved in each interdiction operation, LEA officials believed they would have to spend a considerable amount of effort to document DOD's detection and monitoring participation in individual events; therefore, according to these officials, it would be difficult to gather statistics on DOD's support to drug interdiction.

Even if accurate statistics existed on the number of times DOD's detection of suspected drug smugglers resulted in seizures, DOD officials maintain that there is no established statistical baseline against which to compare DOD's annual contribution to the drug war. Also, they stated that DOD's increased involvement in drug interdiction has been gradual, and statistics at the point of DOD's increased involvement are not available to compare to current or future statistics. According to DOD officials, they are continuing to work to establish a baseline that will allow year-to-year comparisons of activity and/or accomplishments.

## Reliable Measures Are Not Available

LEAs have had difficulty in measuring their own performance. As we reported in 1988 and 1990, although LEAs measure their interdiction success in terms of the numbers of seizures or arrests, these measurements have been criticized as being unreliable indicators of the reduction of



drug supplies.<sup>1</sup> Since DOD officials do not consider current statistical measures of LEA drug interdiction efforts reliable, they believe that developing performance measures for DOD based on LEA measures may not provide reliable measures of DOD's effectiveness in supporting drug interdiction activities.

In addition, a Rand Corporation study on the effect of increased military participation in drug interdiction shows that the effectiveness of interdiction in reducing the availability of illegal drugs cannot be adequately measured by the quantity of drugs seized.<sup>2</sup> Generally, the study prepared for the Under Secretary of Defense for Policy states that (1) unless interdiction can significantly increase the costs of smuggling and therefore the market price of drugs, more effective interdiction will have modest effects on total consumption and (2) a major increase in military support to drug interdiction activities is unlikely to significantly reduce drug consumption in the United States because increases can be negated by shifts in smuggling methods and routes.

## DOD Suggests Qualitative Performance Measures

Responding to congressional interest in determining how to allocate funds for counternarcotics, DOD is developing a performance reporting system for its program. Specific measures of effectiveness for DOD's involvement in drug interdiction have not been finalized. DOD is compiling information on the extent that its interdiction activities have led to or resulted in drug seizures. DOD's Drug Coordinator, however, has stated that

it is inappropriate and unreasonable to judge the performance of the DOD by such artificial body count type standards and statistics as the price of coca leaf at an Andean market, the street price of cocaine in a particular U.S. city, the number of arrests made during a particular period of time, the number of pounds of marijuana confiscated or destroyed, or by similar measures.

DOD admits that this is not to say that its performance should not be evaluated. It has suggested that qualitative measures be used to evaluate its performance of its support to drug interdiction activities. It

<sup>1</sup>Drug Control: Issues Surrounding Increased Use of the Military in Drug Interdiction (GAO/NSIAD-88-156, Apr. 29, 1988) and Drug Interdiction: Funding Continues to Increase But Program Effectiveness In Unknown (GAO/GGD-91-10, Dec. 11, 1990).

<sup>2</sup>Sealing the Borders, The Effects of Increased Military Participation in Drug Interdiction, Peter Reuter, Gordon Crawford, and Johnathan Cave, The Rand Corporation, Santa Monica, Calif., 1988.

maintains that its efforts should be measured against realistic standards, that is, by the quality of its support of the law enforcement community in the implementation of the National Drug Control Strategy.

DOD is currently obtaining feedback from LEAS on the quality of its counternarcotics support. On November 1, 1990, DOD sent questionnaires to LEAS requesting their description and evaluation of DOD's support. LEAS were asked to address, among other things, missions supported, DOD equipment loans, and integration of C3I efforts. DOD plans to use input from their responses to establish a regular reporting mechanism between DOD and LEAS, and it used some response data in its May 22, 1991, report to the Congress from the Secretary of Defense and in the Drug Coordinator's report on counternarcotics activities to the Secretary of Defense. According to DOD officials, DOD is currently developing a means to assess its performance in counternarcotics activities and support.

---

# Major Contributors to This Report

---

## National Security and International Affairs Division, Washington, D.C.

Gary K. Weeter, Assistant Director  
Robert J. Stolba, Evaluator-in-Charge  
Anton G. Blieberger, Senior Evaluator  
Charles R. Climpson, Senior Evaluator  
Elizabeth Mead, Senior Evaluator  
Cynthia A. Steed, Senior Evaluator  
Jean L. Fox, Evaluator  
John Neumann, Evaluator

---

## Norfolk Regional Office

Edward States, Regional Management Representative  
Larry Peacock, Regional Assignment Manager  
James Marshall, Senior Evaluator  
John Pendleton, Evaluator

---

**Ordering Information**

The first five copies of each GAO report are free. Additional copies are \$2 each. Orders should be sent to the following address, accompanied by a check or money order made out to the Superintendent of Documents, when necessary. Orders for 100 or more copies to be mailed to a single address are discounted 25 percent.

**U.S. General Accounting Office  
P.O. Box 6015  
Catthorsburg, MD 20877**

Orders may also be placed by calling (202) 275-6241.





United States  
General Accounting Office  
Washington, D.C. 20548

Official Business  
Penalty for Private Use \$300

First-Class Mail  
Postage & Fees Paid  
GAO  
Permit No. G100